

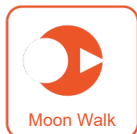

LITHIUM

PSR14

3,000 lbs. Capacity
Walkie Reach Truck



Why choose between price and quality **WHEN YOU CAN HAVE BOTH!**



HIGHLIGHTS

- U Moon Walking - for tight spaces
- U Pantograph reach mechanism
- U Proportional hydraulics - for precision handling
- U Smooth proportional carriage tilt
- U Electric power steering (EPS)
- U Full free lift mast (three stage mast models)
- U Adjustable straddle legs
- U 24V fully electric AC system
- U Lithium battery: 24V/200Ah
- U Fast charging 2 hours
- U Smart handle has LCD display with battery indicator, hour meter and fault code
- U Pinwheel turning - drive with tiller in vertical position
- U Ergonomic control handle with horn and emergency belly button, dual butterfly-style thumb controls for traveling
- U Travel speed: 3.7mph (unloaded), 3.4mph (loaded)
- U Speed reduction in turns
- U Gradeability: 12% (unloaded), 8% (loaded)
- U USB connector

PSR14

3,000 lbs. Capacity

Walkie Reach Truck

The PSR14 Lithium Walkie Reach Trucks, with their breakthrough Moon Walking mode, proportional hydraulics, and pantograph reach mechanism, provide the versatility of two trucks in one - acting as both a counterbalanced lift and a straddle reach truck depending on operator needs. Electric Power Steering (EPS) delivers smooth, precise handling with minimal effort. Operators can navigate tight aisles, position loads with confidence, and work longer without fatigue. With easier steering comes safer operation, faster workflows, and lower maintenance - giving your team the control they need to stay productive all day.

MOON WALK MODE



Moon Walking: A Leap for Safety and Storage Density

Moon Walking mode allows operators to turn the tiller 90° and stand safely at the side of the machine instead of directly behind it. This positioning delivers three critical advantages:

- **Unmatched Visibility:** Operators have a clear view of both the load and surroundings during pick and place operations
- **Space Savings:** The PSR30 requires just 95.13 inches to right-angle stack a standard 40" × 48" pallet, dramatically shrinking aisle width requirements
- **Safer Operation:** By removing the operator from behind the truck, Moon Walking significantly reduces the risk of injury, product damage or fixture damage

Versatility of Two Trucks in One

- When the pantograph is extended, the PSR30 functions like a sit-down counterbalanced truck, supporting any size pallet or load and allowing direct placement from height to the floor
- When retracted, the unit operates like a compact straddle truck, executing extremely tight turns even with a load. This makes it ideal for narrow aisles, tight storerooms, and sideloading flatbed trailers where maneuverability is essential



ERGONOMIC AND SMART TILLER DESIGN

Automatic speed reduction, while turning, helps to prevent product damage.



The new generation tiller head is comfortable and ergonomic, with large buttons that can be easily used by operators, even while wearing gloves.

- A** Turtle speed button (backside)
- B** Forks left/right
- C** Forks forward/backwards
- D** Horn button
- E** Emergency belly button
- F** Dual butterfly-style thumb driving controls
- G** Forks up/down
- H** Fork tilt up/down
- I** Moon walking

Electric Power Steering (EPS) Key Benefits

- ▶ Reduced Operator Effort
- ▶ Improved Maneuverability
- ▶ Increased Productivity
- ▶ Enhanced Safety
- ▶ Lower Maintenance



PINWHEEL CAPABILITY FOR CONFINED SPACES



Turning
Radius

Right Angle Stack with
40x48 Pallet

62.8" **95.13"**

By holding the Turtle button down, the PSR30 Walkie Reach Truck will operate with the handle in the upright position (pinwheel capability), providing safe and easy operation within confined spaces. Dual Butterfly-style thumb controls allow for effortless traveling.

HIGH EFFICIENCY AND GREAT VISIBILITY



Emergency stop button. USB connector for charging and powering of additional devices during operations.

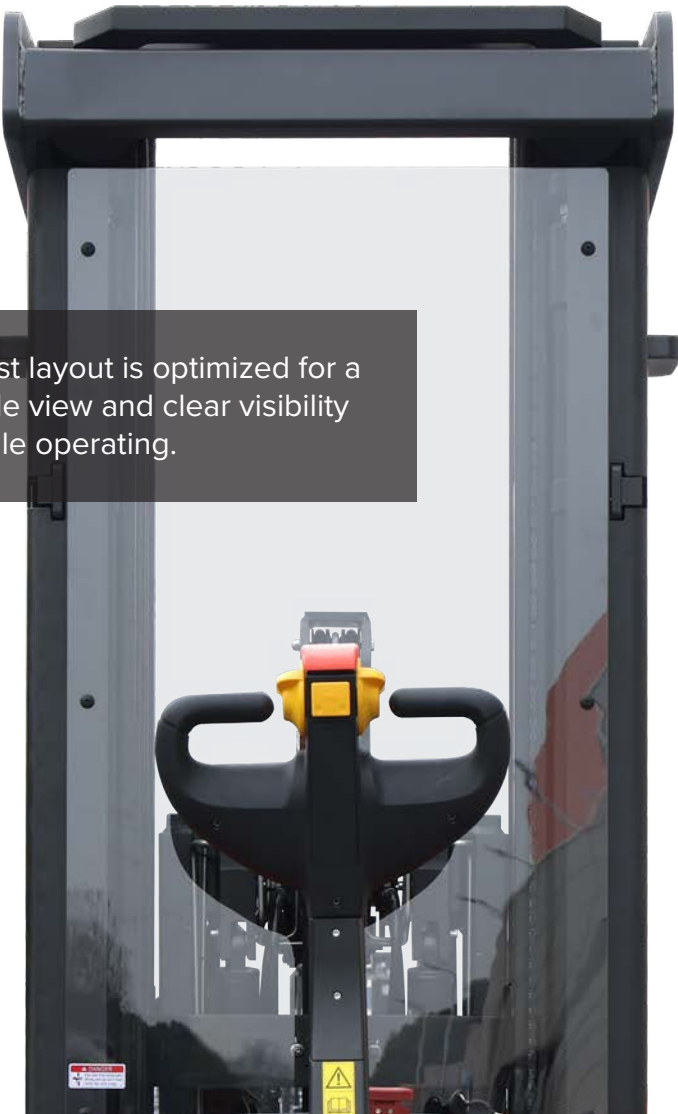

Mast layout is optimized for a wide view and clear visibility while operating.



Two-Stage Mast - Provides 6 inches of free lift, allowing pallets to be raised off the ground without extending the mast, keeping overall height under 84 inches.

Three-Stage Mast - Delivers full free lift, offering maximum flexibility when working under low ceilings.

RUGGED AND SMART DESIGN

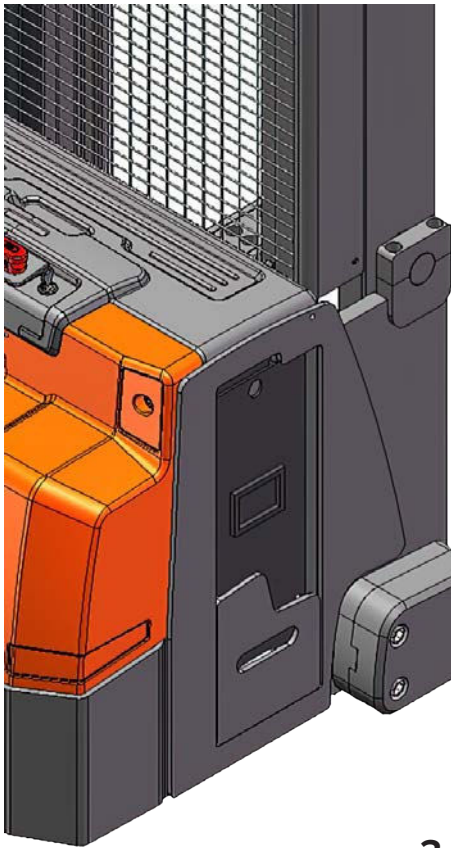

Modular straddle leg rollers can be configured two ways: a standard floating dual-roller setup with 4-inch wheels, or single large 9-inch wheels for better performance on uneven ground or limited outdoor applications.

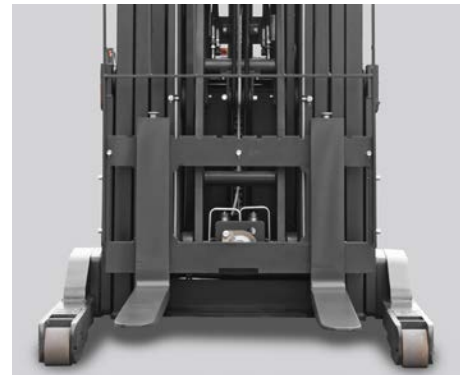
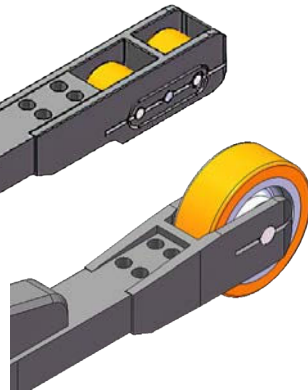

Straddle support legs are easily adjusted to meet operator's needs: I.D. 34" to 50", in 4" increments. Stacker is equipped with a load back rest as standard equipment.

3-Point Structure Design.

Centered drive wheel provides excellent traction and stability. Casters are located to the left and right for additional stability.



The smooth proportional carriage tilt retains loads during transit and compensates for unlevel floors during pick and place operations.

Capacity up to 3,000 lbs and ability to overcome ramps up to 8/12% (laden/ unladen) makes the PSR30 suitable for work in loading docks and on delivery operations.



Up to 8/12%
(laden/ unladen)

RUGGED AND SMART DESIGN



Integrated side shift allows for movement of the fork carriage without having to move the entire stacker.



Proportional hydraulics ensure precise load positioning, while reducing the risk of product or rack damage.



Double hydraulic cylinders provide balanced load movement and prolonged component life.



Frame is surrounded by steel to protect the truck's components and the operator's feet during work.



Innovative steel CJ channel mast design delivers added strength, stability and performance.



Optional fork mounted camera with HDMI color monitor provides an unrestricted view of the pallet and racking.

EASY MAINTENANCE

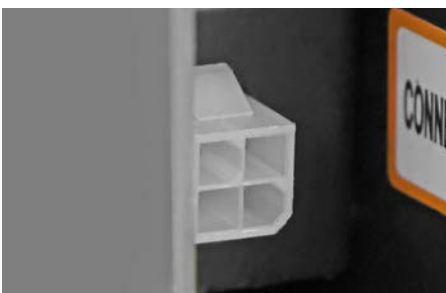

External programming port for diagnosing faults without removing the cover.

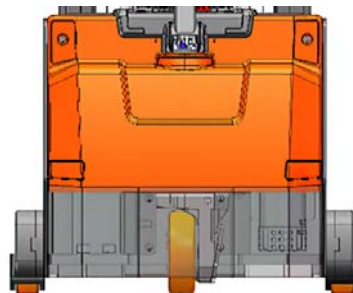

Engineered for service ease, components are quickly and conveniently accessible.

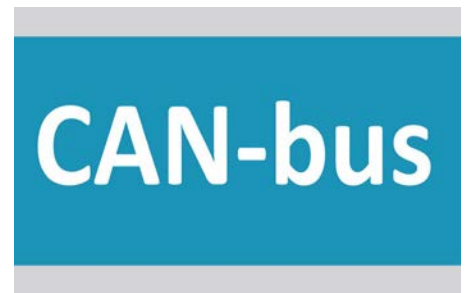

Easily check truck's condition and troubleshoot with CAN-bus technology.

APPLICATIONS

- Supermarkets
- Internal workshops
- Loading docks
- Narrow aisles
- Applications within confined spaces
 - Retail stores
 - Trailers
 - Containers
 - Warehouses
 - Delivery operations



LONG LASTING AND SAFE LITHIUM POWER

NOBLELIFT uses LiFePO4 chemistry, the longest lasting and safest lithium battery chemistry available. Our lithium batteries are equipped with a Battery Management System (BMS), thermal management system, and an automotive-grade DC high-voltage control system. BMS manages charging and discharging data to ensure safety throughout its life cycle.

PSR30 Walkie Reach Trucks have a 3 year or 6,000 hour warranty on the lithium battery cells.



PSR30 Walkie Pantograph Straddle Stacker				
Designation	Lowered mast height h1 (in)	Free lift height h2 (in)	Lift height h3+h13 (in)	Extended mast height h4 (in)
Two-stage mast	73.1	6	106	148.4
	83	6	126	168.1
Three-stage mast FFL (Full Free Lift)	76.4	32.4	157	199.6
	83	39	177	219.3
	87	42.9	189	231.1

Identification				
1.2	Model			PSR30
1.3	Drive (electric – battery or mains, diesel, petrol, fuel gas, manual)			Lithium battery
1.4	Type of operation (hand, pedestrian, standing, seated, order picker)			Pedestrian
1.5	Load capacity / rated load	Q (lb)		3,000
1.6	Load center distance	c (in)		24
1.8	Load distance, center of drive axle to fork	x (in)		14.8
1.9	Wheel base	y (in)		53.7
Weights				
2.1	Service weight	lb		4,894
2.3	Axle loading, fork retracted, unladen front / rear	lb		3,086 / 1,808
2.5	Axle loading, fork retracted, laden front / rear	lb		2,491 / 5,490
Wheels, Chassis				
3.1	Tires (solid rubber, superelastic, pneumatic, polyurethane)			Polyurethane (PU)
3.2	Tire size, front	Øxw (in)		Ø 10 x 3.23
3.3	Tire size, rear	Øxw (in)		Ø 4 x 2.8 (Ø 9 x 3.1)
3.5	Wheels, number front / rear (x = driven wheels)			1x+4 (1x+2)
Basic Dimensions				
4.1	Tilt of mast / fork carriage, forward / backward	°		3/5
4.2	Lowered mast height	h ₁ (in)		87
4.3	Free lift height	h ₂ (in)		42.9
4.4	Lift height	h ₃ +h ₁₃ (in)		189
4.5	Extended mast height	h ₄ (in)		231.1
4.9	Height of tiller in drive position min./max.	h ₁₄ (in)		38 / 51
4.15	Height, lowered	h ₁₃ (in)		2
4.19	Overall length	l ₁ (in)		91
4.20	Length to face of forks	l ₂ (in)		45.6
4.21	Overall width (adjustable)	b ₁ /b ₂ (in)		(42.4 / 46.4 / 50.4 / 54.4 / 58.4)
4.22	Fork dimensions	s/e/l (in)		1.57 / 4 / 45.28
4.25	Distance between fork arms	b ₅ (in)		8.66 - 29.92
4.26	Distance between wheel arms	b ₄ (in)		34 / 38 / 42 / 46 / 50
4.28	Reach distance	l ₄ (in)		22.6
4.32	Ground clearance, center of wheelbase	m ₂ (in)		2
4.33	Right Angle Stack with 40x48 pallet	Ast (in)		95.13
4.34	Right Angle Stack with 32x48 pallet	Ast (in)		96.13
4.35	Turning radius	Wa (in)		62.8
Performance Data				
5.1	Travel speed, laden / unladen	mph		3.4 / 3.7
5.2	Lift speed, laden / unladen	fpm		29.5 / 39.4
5.3	Lowering speed, laden / unladen	fpm		49.2 / 39.4
5.8	Max. gradeability, laden / unladen	%		8 / 12
5.10	Service brake			Electromagnetic
E-Motor				
6.1	Drive motor rating S2 60 min	HP		3.5
6.2	Lift motor rating at S3 15%	HP		6.0
6.4	Battery voltage, nominal capacity Ks	V/Ah		24/200 LiFePO4 (24/360 lead acid option)
6.5	Battery weight	lb		650
6.6	Energy consumption acc. to VDI cycle	kWh/h		1.8
Others				
8.1	Type of drive control			AC-Speed Control
8.4	Sound level at driver's ear acc. to EN 12053	dB (A)		<75
	Sideshift (integrated, standard)	in		+/- 3

NOBLELIFT reserves the right to make technical changes and improvements to our products to maintain or enhance the quality, delivery, and efficiency.