

INSTRUCTION HANDBOOK

Electric Stacker PSE22SL/PSE22MSL

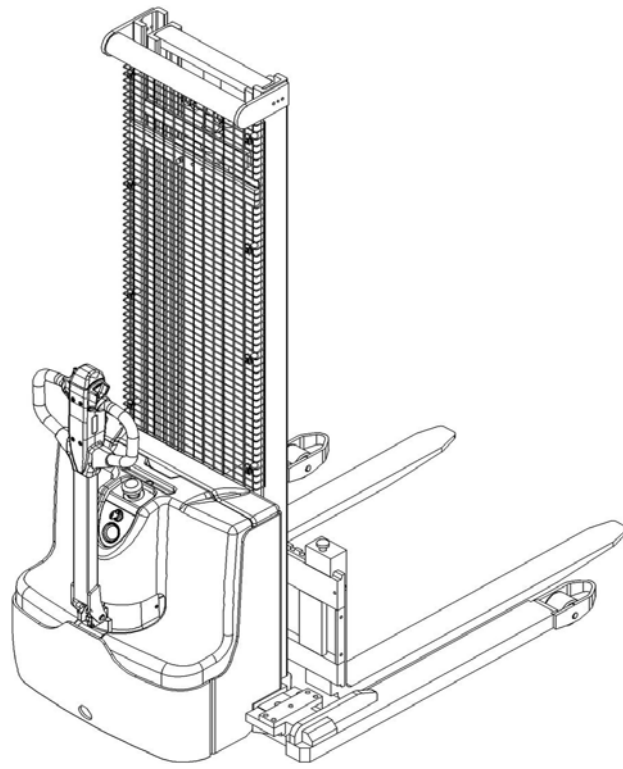
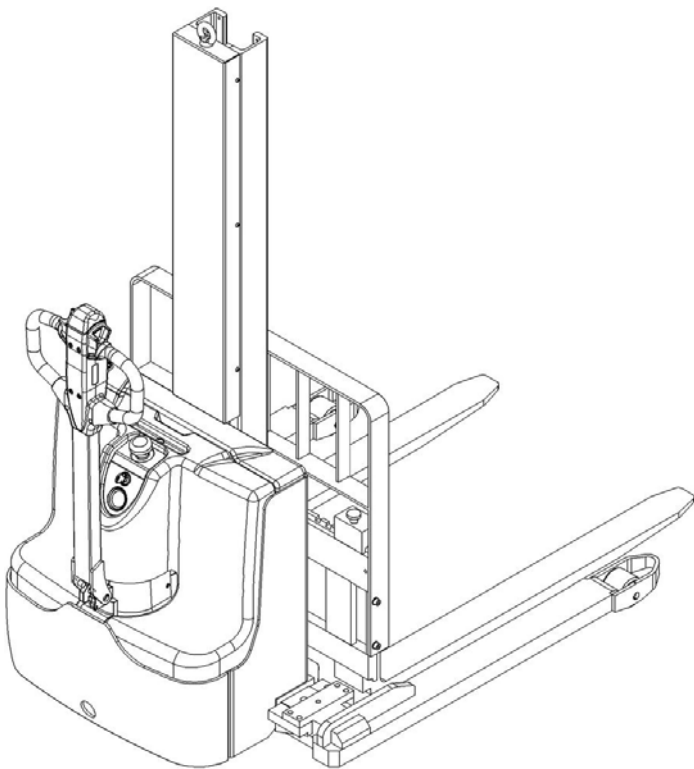

WARNING

Do not use the electric truck before reading and understanding these operating instructions.

NOTE:

- **Please check the designation of your present type at the last page of this document as well as on the ID-plate.**
- **Keep for future reference.**

Version 12/2018

PSE22SL/PSE22MSL-SMS-002-EN

FOREWARD

Before operating the electric stacker, read this ORIGINAL INSTRUCTION HANDBOOK carefully and understand the usage of the truck completely. Improper operation of the truck may create a dangersituation. This handbook describes the usage of different electric stackers. When operating and servicing the truck, make sure, that it applies to your type.

Keep this handbook for future reference. If this or the warning/caution labels are damaged or got lost, please contact your local dealer for replacement.

This truck complies with the requirements according to EN 3691-1 (Industrial trucks- safety requirements and verification, part 1), EN 12895 (Industrial trucks- electromagnetic compatibility), EN 12053 (Safety of industrial trucks- test methods for measuring noise emissions), EN 1175-1 (Industrial truck safety – electrical requirements), assumed the truck is used according to the described purpose.

The noise level for this machine is < 70 dB(A) according to EN 12053.

The vibration is 0,85 m/s² (if equipped with a platform) according to EN 13059.

ATTENTION:

- Environmentally hazardous waste, such as batteries, oil and electronics, will have a negative effect on the environment or health, if handled incorrectly.
- The waste packages should be sorted and put into solid dustbins according to the materials and be collected disposal by local special environment protection bureau. To avoid pollution, it's forbidden to throw away the wastes randomly.
- To avoid leaking during the use of the products, the user should prepare some absorbable materials (scraps of wooden or dry duster cloth) to absorb the leaking oil in time. To avoid second pollution to the environment, the used absorbable materials should be handed in to special departments in terms of local authorities.
- Our products are subject to ongoing developments. The information written in this handbook is provided as reference for operating and servicing the stacker and may vary in terms of description of particular features of the truck.



NOTE: On this manual, the left sign means warning and danger, which can lead to death or serious injury if not followed.

Copyright

The copyright remains with the company, mentioned on the CE- certificate at the end of this document or, if sold within the USA, with the company, mentioned on the company sticker.

TABLE OF CONTENTS

1. CORRECT APPLICATION	3
2. DESCRIPTION OF THE STACKER.....	4
a. Overview of the main components	4
b. Main technical data	5
c. Description of the safety devices and warning labels (USA)	9
d. Identification plate	10
3. WARNINGS, RESIDUAL RISK AND SAFETY INSTRUCTIONS	10
4. COMMISSIONING, TRANSPORTING, DECOMMISSIONING	11
a. Commissioning.....	11
b. Lifting/transportation.....	11
c. Decommissioning.....	13
5. DAILY INSPECTION.....	13
6. OPERATING INSTRUCTIONS	13
a. Parking	14
b. Residual lift diagram.....	14
c. Lifting.....	15
d. Lowering.....	15
e. Travelling.....	15
f. Steering	16
g. Braking.....	16
h. Malfunctions	16
i. Emergency	16
7. BATTERY CHANGING AND REPLACEMENT	17
a. Replacement.....	17
b. Battery indicator	18
c. Charging.....	18
8. REGULAR MAINTENANCE	19
a. Maintenance checklist.....	19
b. Lubricating points	21
c. Check and refill hydraulic oil.....	21
d. Checking electrical fuses	21
e. Removing, reattaching guarding	22
9. TROUBLE SHOOTING.....	22
10. WIRING/ CIRCUIT DIAGRAM	24
a. Electrical circuit diagram	24
b. Hydraulic circuit.....	25

1. CORRECT APPLICATION

It is only allowed to use this electric stacker according to this instruction handbook.

The trucks described in this handbook are self propelled pedestrian controlled electric power stacker, with electrically operated lifting function. The trucks are designed for stacking operations in dedicated racking by lifting and lowering the palletized load up to the desired lifting height.

A wrong usage can cause human injuries or can damage equipment.

The operator/ the operating company has to ensure the correct usage and has to ensure, that this truck is used only by staff, which is trained and authorized to use this truck.

The truck has to be used on substantially firm, smooth, prepared, level and adequate surfaces. The truck is intended to be used for indoor applications with ambient temperatures between +5°C and + 40°C and for light duty applications without crossing permanent obstacles or potholes. Operating on ramps is not allowed. While operating, the load must be placed approximately on the longitudinal centre plane of the stacker. Lifting or transporting people is forbidden. If travelling the load must be lowered to the lifting point.

It is not allowed to use this truck on tail lifts or loading ramps.

The capacity is marked on the load diagram as well on the Identification plate. The operator has to consider the warnings and safety instructions. Operating lighting must be minimum 50 Lux.

Modification

No modifications or alterations to this truck which may affect, for example, capacity, stability or safety requirements of the truck, shall be made without the prior written approval of the original truck manufacturer, its authorized representative, or a successor thereof. This includes changes affecting, for example braking, steering, visibility and the addition of removable attachments. When the manufacturer or its successor approve a modification or alteration, they shall also make and approve appropriate changes to capacity plate, decals, tags and operation and maintenance handbooks.

By not observing these instructions, the warranty becomes void.

2. DESCRIPTION OF THE STACKER

a. Overview of the main components

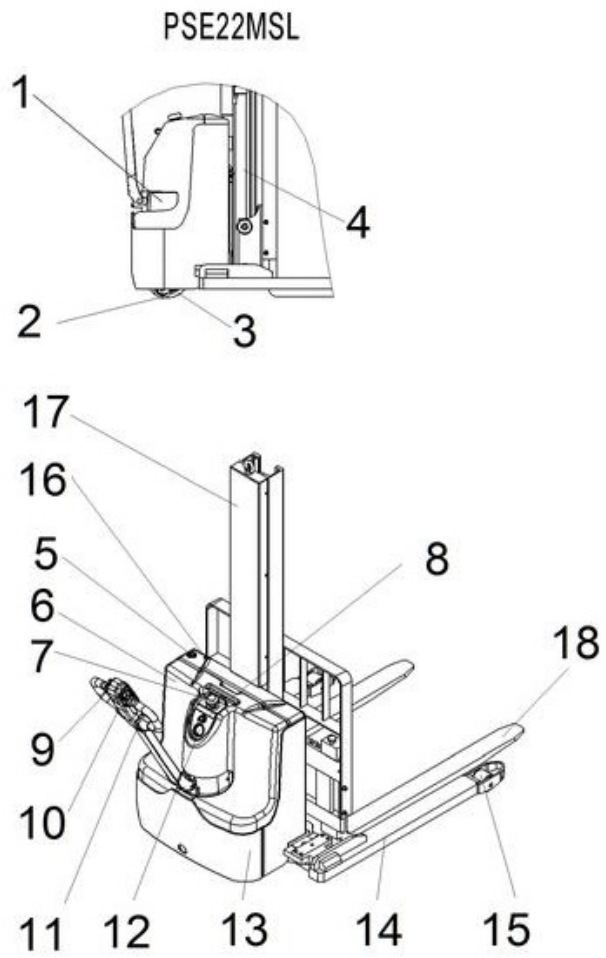
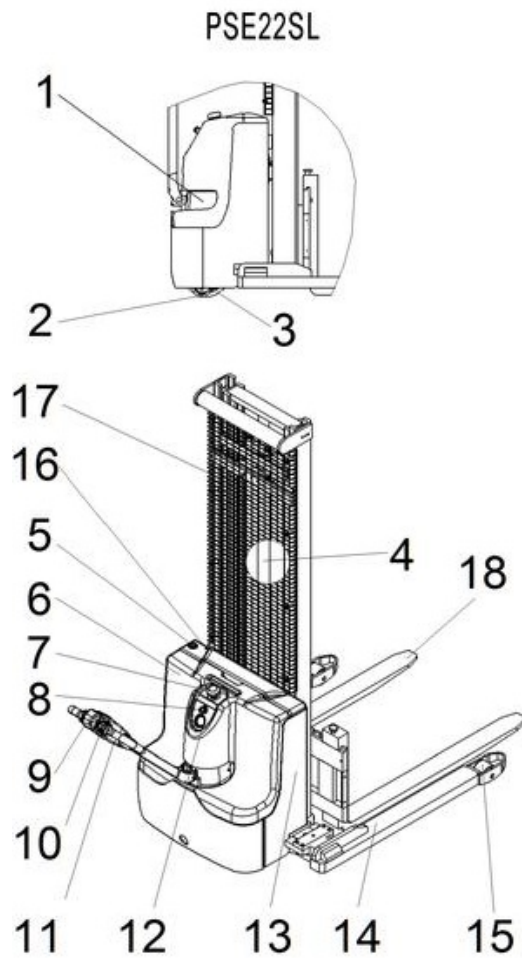

- 1 Drive motor cover
- 2 Balance wheel
- 3 Drive wheel
- 4 Hydraulic cylinder
- 5 Charging cable
- 6 Main cover
- 7 Emergency button
- 8 Key switch
- 9 Safety (belly) button

- 10 Accelerator (butterfly- switch)
- 11 Multifunction tiller
- 12 Electricity meter
- 13 Chassis with mast
- 14 Leg
- 15 Load wheel
- 16 Charging indicating LED
- 17 Protective screen
- 18 Forks

b. Main technical data

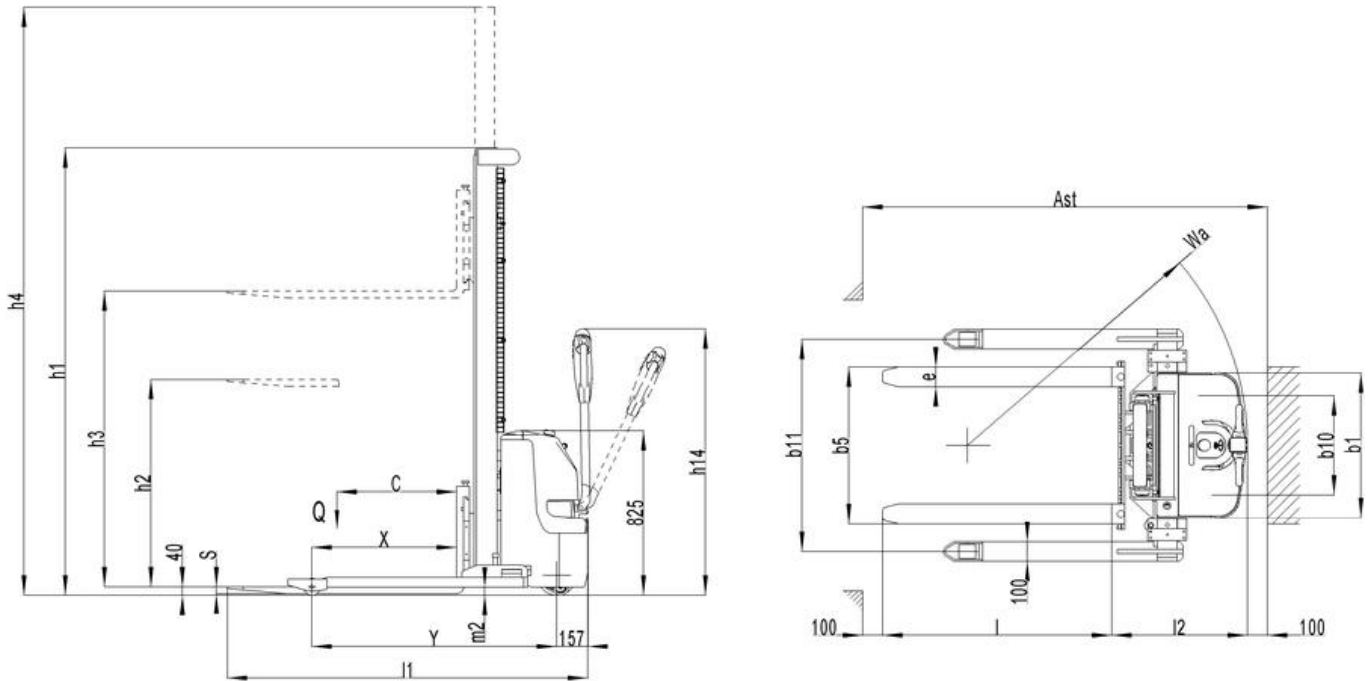

Fig. 2: Technical data (PSE22SL)

Table 1: Main technical data for standard version (PSE22SL)

Type sheet for industrial truck acc. to VDI 2198						
Distinguishing mark	1.2	Manufacturer's type designation		PSE22SL(114)	PSE22SL(126)	PSE22SL(138)
	1.3	Drive		Battery		
	1.4	Operator type		Pedestrian		
	1.5	Load Capacity / rated load	Q (lbs)	2200		
	1.6	Load centre distance	C (in)	23.6		
	1.8	Load distance ,centre of drive axle to fork	X (in)	28.5		
	1.9	Wheelbase	Y(in)	48.3		
Weight	2.1	Service weight	lbs	1588.4	1621.4	1654.4
	2.2	Axle loading, laden front/rear	lbs	1269.4/2503.6	1280.4/2525.6	1291.4/2547.6
	2.3	Axle loading, unladen front/rear	lbs	1128.6/481.8	1150.6/470.8	1172.6/481.8
Tyres, Chassis	3.1	Tires		Polyurethane (PU)		
	3.2	Tire size, front	∅ x w (in)	Φ7.8×2.9		
	3.3	Tire size, rear	∅ x w (in)	Φ3.3×2.8		
	3.4	Additional wheels(dimensions)	∅ x w (in)	Φ3.1 × 1.2		
	3.5	Wheels,number front/rear(x=driven wheels)		1x+2/2		
	3.6	Tread, front	b10(in)	19.6		
	3.7	Tread, rear	b11 (in)	42.1-53.9		
Dimensions	4.2	Lowered mast height	h1 (in)	76.6	82.5	88.4
	4.3	Free Lift height	h2 (in)	2.8		
	4.4	Lift	h3 (in)	111.8	123.6	135.4
	4.5	Extended mast height	h4 (in)	134.6	146.5	158.3

	4.9	Height of tiller in drive position min./ max.	h14(in)	32.5/49.2
	4.15	Height, lowered	h13(in)	1.6
	4.19	Overall length	l1(in)	71.3
	4.20	Length to face of forks	l2(in)	26
	4.21	Overall width	b1(in)	28.6
	4.22	Fork dimensions	s/ e/ l(in)	1.4/3.9/45.3
	4.25	Distance between fork- arms	b5 (in)	9.9-31.5
	4.32	Ground clearance, centre of wheelbase	m2(in)	1.6
	4.33	Aisle width for pallets 1000X1200	Ast (in)	88.6
	4.34	Aisle width for pallets 800X1200	Ast (in))	86.6
	4.35	Turning radius	Wa (in)	55.3
	Performance data	5.1	Travel speed, laden/ unladen	mph
5.2		Lift speed, laden/ unladen	fpm	0.021/0.029
5.3		Lowering speed, laden/ unladen	fpm	0.02/0.02
5.8		Max. gradeability, laden/ unladen	%	5/10
5.10		Service brake		Electromagnetic
Electric- motor	6.1	Drive motor rating S2 60min	hp	0.6
	6.2	Lift motor rating at S3 7.5%	hp	2.95
	6.3	Battery acc. to DIN 43531/ 35/ 36 A, B, C, no		no
	6.4	Battery voltage, nominal capacity K5	V/Ah	2x12/85
	6.5	Battery weight	lbs	2x55
	6.6	Energy consumption acc. to VDI cycle	kWh/h	0.62
Additional data	8.1	Type of drive control		DC- Speed Control
	8.4	sound level at driver's ear acc. to EN 12053	db(A)	<70

- 1) Optional: 1.4/3.9/37.4
- 2) Optional: 2x12V / 106 Ah

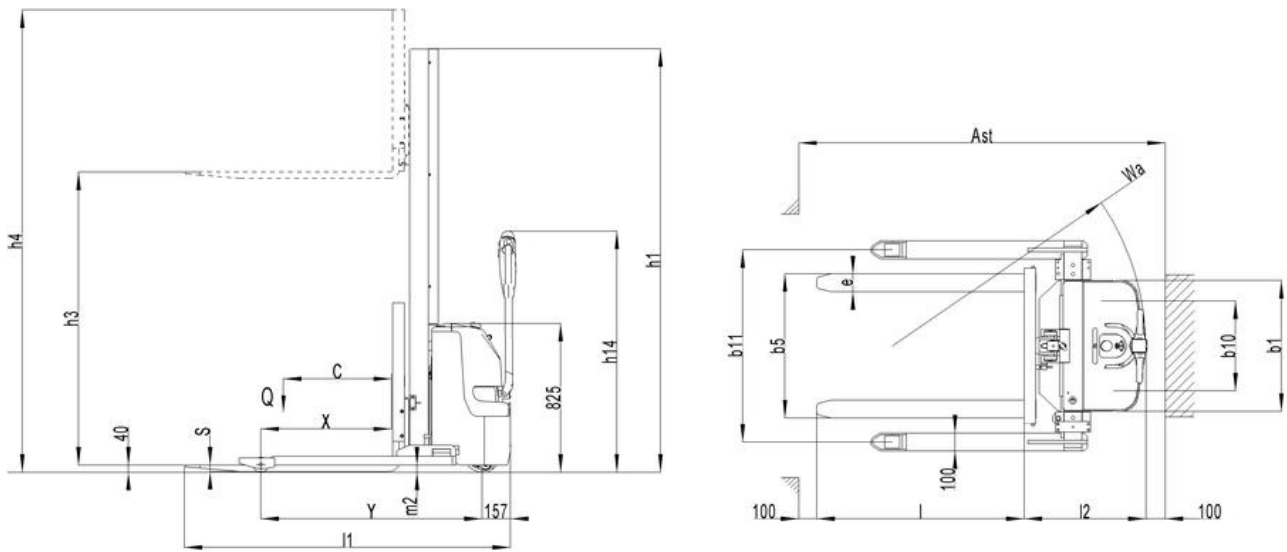

Fig. 3: Technical data (PSE22MSL)

Table 2: Main technical data for standard version (PSE22MSL)

Type sheet for industrial truck acc. to VDI 2198					
Distinguishing mark	1.2	Manufacturer's type designation		PSE 22MSL(63)	PSE 22MSL(79)
	1.3	Drive		Battery	
	1.4	Operator type		Pedestrian	
	1.5	Load Capacity / rated load	Q (lbs)	2200	
	1.6	Load centre distance	C (in)	23.6	
	1.8	Load distance ,centre of drive axle to fork	X (in)	28.8	
Weight	1.9	Wheelbase	Y(in)	48.3	
	2.1	Service weight	lbs	1401.4	1430
	2.2	Axle loading, laden front/rear	lbs	1139.6/2444.2	1148.4/2464
Tyres, Chassis	2.3	Axle loading, unladen front/rear	lbs	994.4/407	1014.2/415.8
	3.1	Tires		Polyurethane (PU)	
	3.2	Tire size, front	∅ x w (in)	Φ7.8×2.9	
	3.3	Tire size, rear	∅ x w (in)	Φ3.3×2.8	
	3.4	Additional wheels(dimensions)	∅ x w (in)	Φ3.1 × 1.2	
	3.5	Wheels, number front/rear(x=driven wheels)		1x+2/2	
	3.6	Tread, front	b ₁₀ (in)	19.6	
Dimensions	3.7	Tread, rear	b ₁₁ (in)	41.9-53.9	
	4.2	Lowered mast height	h ₁ (in)	76.8	92.5
	4.3	Free Lift height	h ₂ (in)	60.2	76
	4.4	Lift	h ₃ (in)	60.2	76
	4.5	Extended mast height	h ₄ (in)	97.2	113
	4.9	Height of tiller in drive position min./ max.	h ₁₄ (in)	32.5/49.2	
	4.15	Height, lowered	h ₁₃ (in)	1.6	
	4.19	Overall length	l ₁ (in)	71.3	
	4.20	Length to face of forks	l ₂ (in)	26	
	4.21	Overall width	b ₁ (in)	28.6	
4.22	Fork dimensions	s/ e/ l(in)	1.4/3.9/45.3		

	4.25	Distance between fork- arms	b ₅ (in)	9.9-31.5
	4.32	Ground clearance, centre of wheelbase	m ₂ (in)	1.6
	4.33	Aisle width for pallets 1000X1200 crossways	Ast(in)	89.1
	4.34	Aisle width for pallets 800X1200 lengthways	Ast(in))	87.4
	4.35	Turning radius	Wa(in)	55.3
Performance data	5.1	Travel speed, laden/ unladen	mph	2.3/2.5
	5.2	Lift speed, laden/ unladen	fpm	0.02/0.04
	5.3	Lowering speed, laden/ unladen	fpm	0.03/0.02
	5.8	Max. gradeability, laden/ unladen	%	5/10
	5.10	Service brake		Electromagnetic
Electric-motor	6.1	Drive motor rating S2 60min	hp	0.6
	6.2	Lift motor rating at S3 7.5%	hp	2.95
	6.3	Battery acc. to DIN 43531/ 35/ 36 A, B, C, no		no
	6.4	Battery voltage, nominal capacity K5	V/Ah	2x12/85
	6.5	Battery weight	lbs	2x55
	6.6	Energy consumption acc. to VDI cycle	kWh/h	0.62
Additional data	8.1	Type of drive control		DC- Speed Control
	8.4	sound level at driver's ear acc. to EN 12053	db(A)	<70

- 1) Option: 2x12V / 106 Ah
- 2) Optional: 1.4/3.9/37.4

C. Description of the safety devices and warning labels (USA)

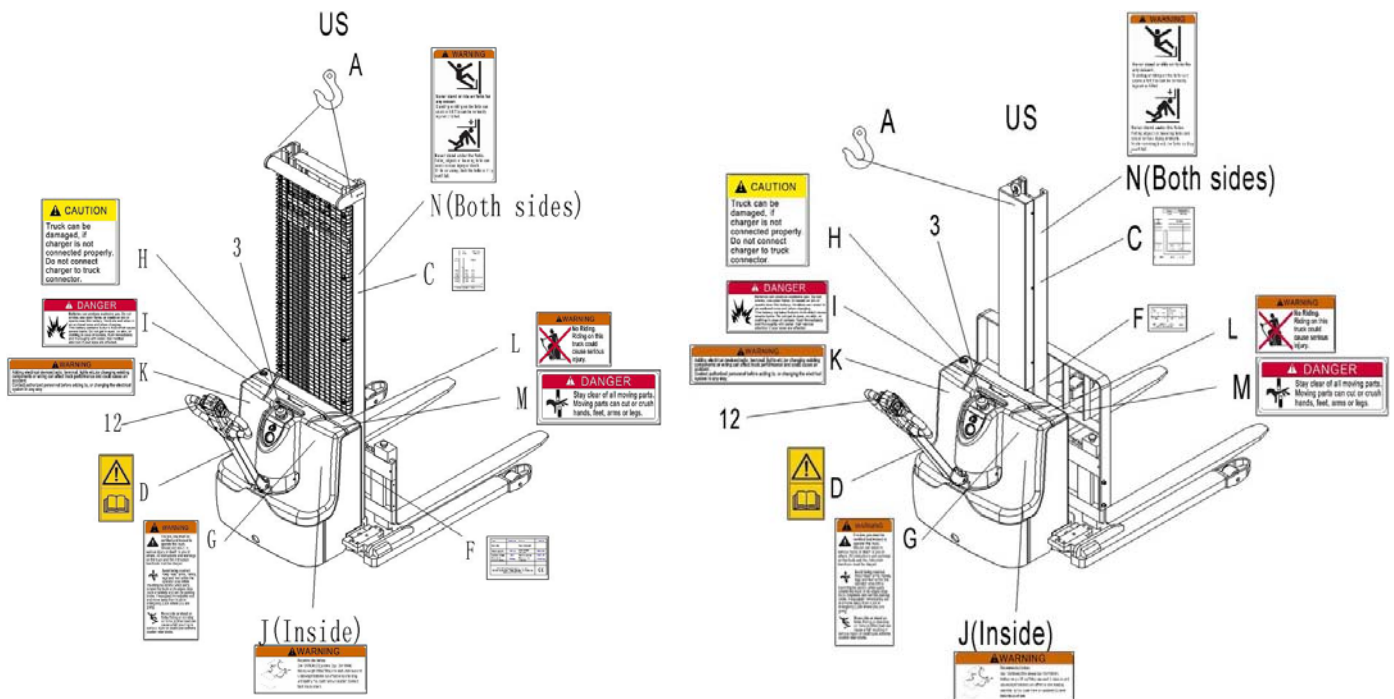

Fig. 4: Warning labels and safety devices

- | | | | |
|---|---|----|---------------------------------|
| A | Crane hook label | I | Sign danger battery |
| N | Sign not under, on forks | J | Sign warning battery size |
| C | Residual lift capacity sticker | K | Sign warning electrical devices |
| D | Sticker to read and follow these instructions | L | Sign danger not riding |
| F | Identification plate (ID-plate) | M | Sign danger being crushed |
| G | Sign warning stay clear stop truck | 3 | Combined emergency switch |
| H | Sign Caution charger | 12 | Safety (belly) button |

The truck has an emergency button 7 (Fig. 1) which stops all lifting-, lowering-, driving- functions and engages the failsafe electromagnetic brake when it is pushed. By pulling this button, the truck can be operated after the controller checked the functions. Before operating, insert the key and turn the switch 8 (Fig. 1) clockwise. To prevent against unauthorized access, turn the key anti-clockwise and remove it, if you not operate this truck. The truck is equipped with a safety button 9 (Fig. 1) which switches the driving function away from the operator, if the truck travels towards the operator and the tiller is activated in the tillers operating zone. Follow also the instructions given on the decals. Replace the decals if they are damaged or missing.

d. Identification plate

- | | | | |
|---|--|----|---------------------------------|
| 1 | Designation, type | 7 | Battery weight minimum/ maximum |
| 2 | Serial number | 8 | Nominal power in kW |
| 3 | Rated capacity in kg | 9 | Load center distance |
| 4 | Supply voltage in V | 10 | Manufacturing data |
| 5 | Own mass (self weight) in kg without battery | 11 | Option |
| 6 | Name and address of manufacturer) | | |

1	Type	xxx xx	Option	xx X xxxx	
2	Serial No.	xxxxx	Year of Manuf.	MM/YYYY	
3	Rated capacity	xxxx kg	Load center distance	xxx mm	11
4	System voltage	xx V	Nominal power	xx kW	10
5	Net weight without battery	xxx kg	Battery mass min/max	xxx / xxx kg	9
					8
6	XXXX XXXX XXXXXXXX xx XXXXX / XXXXXX			CE	7

Fig. 5: Identification plate

If sold to the EU, here the place of the CE marking

3. WARNINGS, RESIDUAL RISK AND SAFETY INSTRUCTIONS



DO NOT

- Drive outside the stacking operation with a lifted load higher than the lifting point.
- Put foot or hand under or into the lifting mechanism.
- Allow other person than the operator to stand in front of or behind the truck when it is moving or lifting/lowering.
- Overload the truck.
- Put foot in front of the wheels, injury could result.
- Lift people. People could fall down and suffer severe injury.
- Push or pull loads.
- Use this truck on ramps.
- Use the truck without a removed protective screen (Fig.1, pos. 17/ guarding).
- Side or end load. Load must be distributed evenly on the forks.
- Use the truck with unstable, unbalanced not stable load.
- Use truck without manufacturer's written consent.
- Supply on board charger with AC voltage other than 110V or 220V.

Watch difference in floor levels when driving. Load could fall down or the truck could get uncontrollable. Keep watching the condition of load. Stop operating the truck if load becomes unstable. Brake the truck and activate the emergency button (7) by pushing when sliding load on or off the truck. If the truck has any malfunctions, follow chapter 6.

Practice maintenance work according to regular inspection. This truck is not designed to be water resistant. Use the truck under dry condition. Prolonged continuous operation might cause damage of the power pack. Stop operation if temperature of hydraulic oil is too high.



- When operating the truck, the operator has to wear safety shoes.
- The truck is intended to be used for indoor applications with ambient temperatures between +5°C and + 40°C.
- The operating lighting must be minimum 50 Lux.
- It is not allowed to use the truck on ramps.
- To prevent unintended sudden movements when not operating the truck (i.e. from another person, etc.). Switch of the truck and remove the key.

4. COMMISSIONING, TRANSPORTING, DECOMMISSIONING

a. Commissioning

Table 3: Commissioning data

Type	PSE22SL(114)	PSE22SL(126)	PSE22SL(138)	PSE22MSL(63)	PSE22MSL(79)
Commissioning weight [kg]	1632.4	1665.4	1698.4	1445.4	1474
Version/ Lift [mm]	111.8	123.6	135.4	60.2	76

After receiving our new truck or for re-commissioning you have to do following before (firstly) operating the truck:

- Check if are all parts included and not damaged
- Eventually installation and charging the batteries (follow chapter 7)
- Do the work according to the daily inspections as well as functional checks.

b. Lifting/transportation

For transporting, remove the load, lower the forks to the lowest position and fix the truck safe with dedicated lifting gear according to the following figures.

Lifting



USE DEDICATED CRANE AND LIFTING EQUIPMENT
DO NOT STAND UNDER THE SWAYING LOAD
DO NOT WALK INTO THE HAZARDOUS AREA DURING LIFTING

Park the truck securely and lash the truck according to the points identified in Fig. 6
Lift the truck to its destination and place the truck securely before removing the lifting gear.

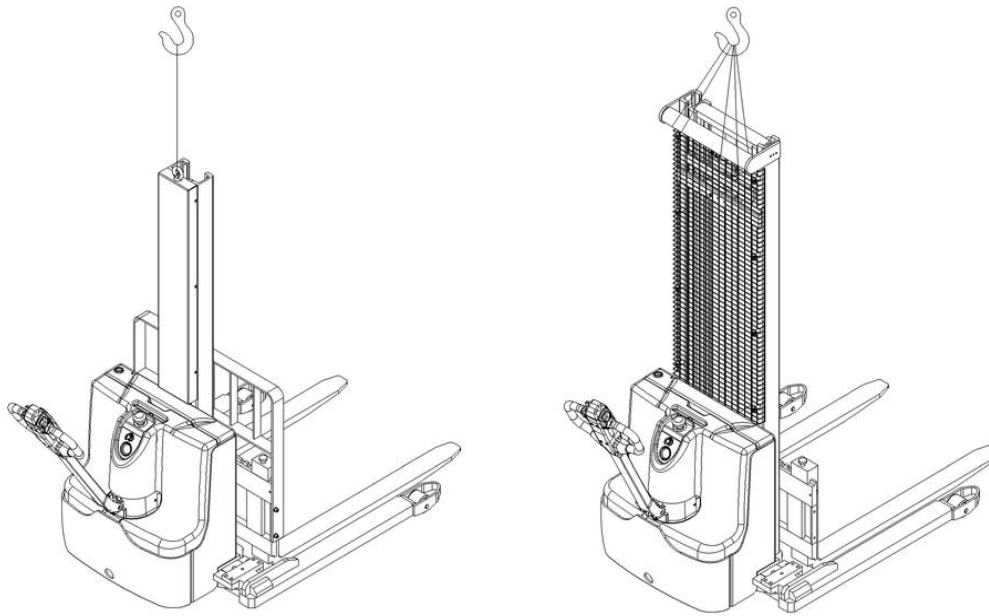

Fig. 6: Lifting with a crane

Transportation



DURING TRANSPORTATION ON A LORRY OR TRUCK ALWAYS FASTEN THE TRUCK SECURELY

Lower the forks and park the truck securely. Fasten the truck according to Fig. 7 by fixing dedicated lashing belts at both sides each 2 pc of the trucks upper mast traverse and fasten the other side at the transporting truck.

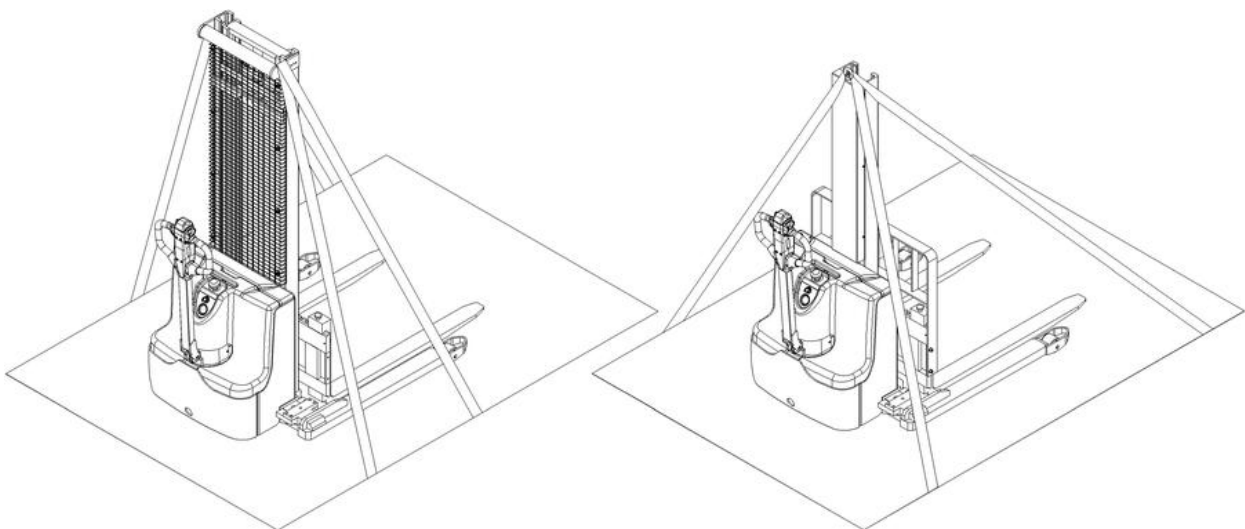

Fig. 7: Fixing points

C. Decommissioning

For storage, remove the load, lower the truck to the lowest position, grease all in this handbook mentioned greasing points (regular inspection), eventual protect the truck against corrosion and dust. Remove the batteries and jack the truck safety, so that there will be no flattening after storage.

For final decommissioning hand the truck to a designated recycling company. Oil, batteries and electric components must be recycled due to legal regulations.

5. DAILY INSPECTION

This chapter describes pre-shift checks before putting the truck into operation.

Daily inspection is effective to find the malfunction or fault on this truck. Check the truck on the following points before operation.



Remove load from truck and lower the forks.

DO NOT USE THE TRUCK IF ANY MALFUNCTION IS FOUND.

- Check for scratches, deformation or cracks.
- Check if there is any oil leakage from the cylinder.
- Check the vertical creep of the truck.
- Check the chain and rollers for damages or corrosion.
- Check the smooth movement of the wheels.
- Check the function of the emergency brake by activating the emergency button.
- Check, the tiller arm- switch braking function
- Check the lifting and lowering functions by operating the buttons.
- Check if the protective screen has no damages and that is correctly assembled.
- Check the audio warning signal.
- Check if all bolts and nuts are tightened firmly.
- Check the function of the key switch.
- Check the speed limitation switch.
- Visual check if there are any broken hoses or broken electric wires.
- If supplied with a backrest extension, check it for damages and correct assembling.

6. OPERATING INSTRUCTIONS



BEFORE OPERATING THIS TRUCK, PLEASE FOLLOW THE WARNINGS AND SAFETY INSTRUCTIONS (CHAPTER 3).

BEFORE OPERATING THIS TRUCK, ENSURE THAT THE LOAD OR OTHER EQUIPMENT NOT CAUSES INSUFFICIENT VISIBILITY!

Make sure, that the load is palletized and stable and that the daily inspection is carried out. For starting, insert the key and turn it clockwise to the “ON”- position. The key can be used only used on pedestrian controlled power stacker. Eventually before inserting the key, the emergency button must be pulled carefully.

Press the horn button 21(Fig 8) to activate the audible warning signal.

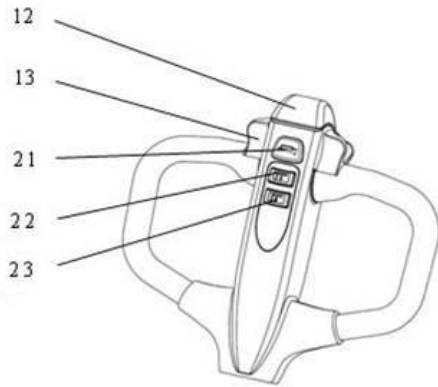

Fig.8: Tiller operating controls

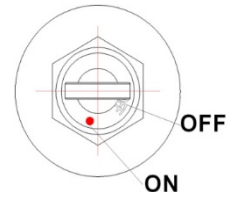

Fig. 9: Key switch

a. Parking



DO NOT PARK THE TRUCK ON INCLINED SURFACES

The truck is equipped with an electromagnetic failsafe stopping and parking brake.

Always lower the forks fully and drive the truck to a safe area. Turn the key anti- clockwise to the “Off” – position and remove the key.

b. Residual lift diagram

The residual lift diagram indicates the maximum capacity Q [kg] for a given load centre c [mm] and the corresponding lift height H [mm] for the truck with horizontal load.

The white markings on the mast indicate if the specific lifting limits reached.

For instance with a load centre of gravity distance c of 23.6in and a maximum lift height H of 137.8in, the max. capacity Q is 1320lbs.

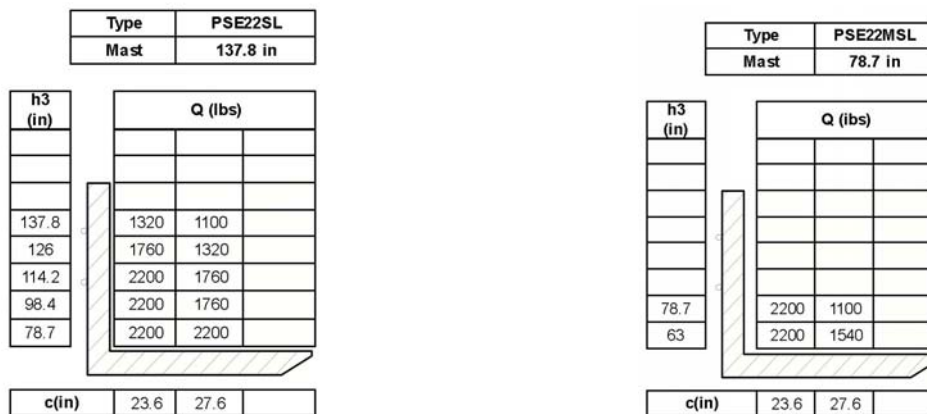

Fig. 10: Residual lift diagram (without side shift)

c. Lifting



DO NOT OVERLOAD THE TRUCK! THE MAXIMUM CAPACITY IS 2200lbs.LIFT ONLY CAPACITIES ACCORDING TO THE RESIDUAL LIFT DIAGRAM.

Travel with the lowered forks fully underneath the pallet and press the lifting button (Fig. 8, 22) until you reached the desired lifting height.

d. Lowering

If the forks are in the racking, firstly travel out of the racking carefully with or without the pallet.

Press the lowering button (Fig. 8, 23) carefully.

Lower the load until the forks are clear of the pallet, then drive the truck carefully out of the load unit.

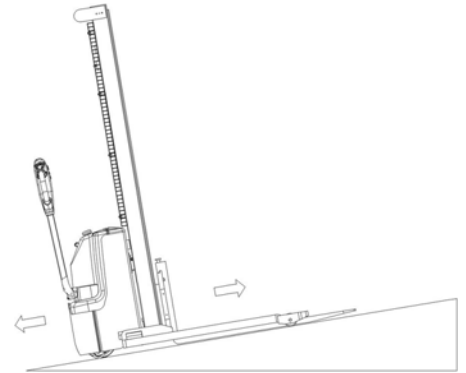

Fig.11:Load facing uphill

e. Travelling



TRAVEL ON INCLINES ONLY WITH THE LOAD FACING UPHILL.

DO NOT TRAVEL ON INCLINES MORE THAN SPECIFIED WITH THE TECHNICAL DATA.

TRAVELLING IS ONLY ALLOWED IF THE FORKS ARE LOWERED DOWN TO THE LIFTING POINT (<11.8in).

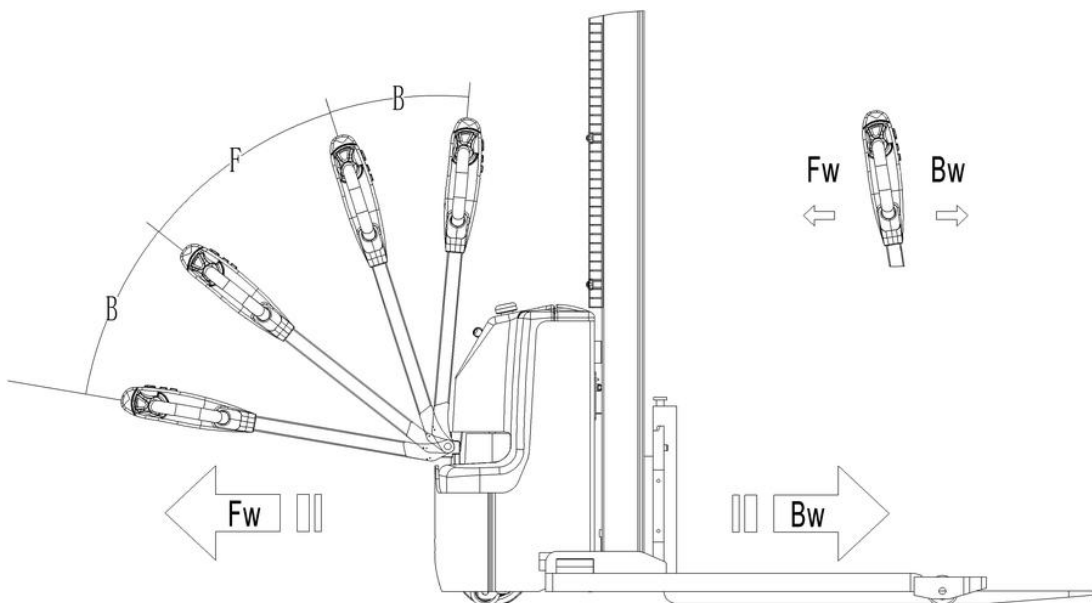

Fig.12: Operating direction

After starting the truck by turning the inserted key to the "ON"- position (Fig. 9; and eventually by pulling the emergency button carefully), move the tiller to the operating zone ('F', Fig.12).

Turn the accelerator button to the desired direction forward 'Fw.' Or backwards 'Bw.'(Fig. 12).

Control the travelling speed by moving the accelerator button (12) carefully until you reached the desired speed.

If you move the accelerator button back to the neutral position, the controller decelerates the truck until the truck stops. If the truck stopped, the parking brake will be engaged.

Drive carefully the truck to the destination. Watch the route conditions and adjust the travelling speed with the accelerator- button.

f. Steering

You steer the truck by moving the tiller to the left or right side.

g. Braking



THE BRAKING PERFORMANCE DEPENDS ON THE TRACK CONDITIONS AND THE LOAD CONDITIONS OF THE TRUCK

The braking function can be activated on several ways(Fig 8, Fig 12):

- By moving the accelerator button (Fig 8, 13) back to the initial '0' position or by releasing the button, the regenerative braking is activated. The truck brakes until it stops.
- By moving the accelerator button (Fig 8,13) from one driving direction directly to the opposite direction, the truck brakes regenerative until it starts travelling into the opposite direction.
- The truck brakes, if the tiller is moved up or down to the braking zone ('B'). If the tiller is released, the tiller moves automatically up to the upper braking zone('B'). The truck brakes until it stops.
- The safety (belly) button (Fig 8, 12) prevents the operator from being crushed. If this button is activated, the truck decelerates and/ or starts travelling into the backwards direction ('Bw.') for a short distance and stops. Please consider, that this button also operates, if the truck is not travelling and the tiller is in the operating zone.

h. Malfunctions

If there are any malfunctions or the truck is inoperative, please stop using the truck and activate the emergency button 7 (Fig 1) by pushing it. If possible, park the truck on a safe area, turn the key switch 8 (Fig 1) anti- clockwise and remove the key.

Inform immediately the manager and, or call your service. If necessary, tow the truck out of the operating area by using dedicated lifting equipment.

i. Emergency

In emergencies, push the emergency button 7 (Fig 1). All electrical functions will be stopped. Keep safe distance.

7. BATTERY CHANGING AND REPLACEMENT



- Only qualified personnel are allowed to service or charge the batteries. The instructions of this handbook and from the battery- manufacturer must be observed.
- These batteries are maintenance free; re- filling is prohibited.
- Recycling of batteries undergoes national regulations. Please follow these regulations.
- By handling batteries, open fire is prohibited, gases could cause explosion!
- In the area of battery charging neither burning materials nor burning liquids are allowed. Smoking is prohibited and the area must be ventilated.
- Park the truck securely before starting charging or installing/changing the batteries
- Before finishing the maintenance work, make sure, that all cables are connected correctly and that there are no disturbing towards other components of the truck.

The truck is equipped with following sealed liquid acid batteries:

2 pc 12V/ 85Ah(C5)
2 pc 12V/ 106Ah



IT IS ONLY ALLOWED TO USE SEALED LIQUID ACID BATTERIES.
THE WEIGHT OF THE BATTERIES HAS AN INFLUENCE TO THE TRUCKS OPERATING BEHAVIOR.
PLEASE CONSIDER THE MAXIMUM OPERATING TEMPERATURE OF THE BATTERIES.

a. Replacement

Park the truck securely and switch off the stacker with the key 1 (Fig1, 8) and activate the emergency button 3 (Fig1, 7). Unbolt the screw on the main cover and remove the cover. Unbolt the screws of the negative terminals (indicated with '-') firstly, then unbolt the screws of the positive terminals (indicated with '+') and put the cables aside.

Unbolt the batteries fixing bars and remove these (Fig13, 1). Remove the batteries carefully by observing not to hit the upper electrical instruments board or the upside oil tank. The installation is in the reverse order of the removal. Please connect the positive terminals firstly. Otherwise the tuck could be damaged.

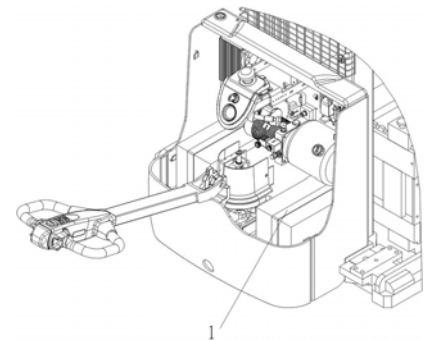
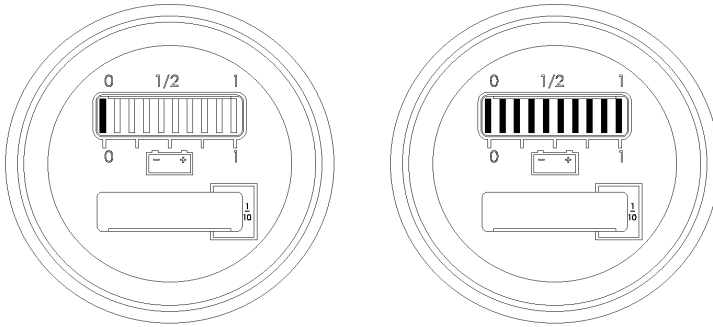

Fig. 13: Battery replacement

b. Battery indicator

The discharge status is indicated by ten red LED segments.



Battery discharged

Battery charged

Fig.14: Battery discharge indicator

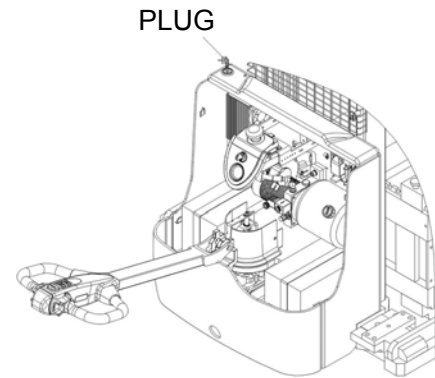

Fig.15: Battery charging

Only when the battery is properly charged, the most right LED lit. As the battery's state-of-charge decreases, successive LEDs light up, only one on at a time.

- The 2nd from left LED flashes, indicating “energy reserve” (70% depth of discharge).
- The 2 most left LEDs alternately flash, indicating “empty” (80% depth of discharge).

c. Charging



- The attached automatic charger is only available for the optional voltage of 110V or 220V as referred.
- The room, where you are charging must be ventilated.
- The exactly charge status can be only checked from the discharge indicator. To control the status, the charging must be interrupted and the truck must be started.

Park the truck at a dedicated secured area with a dedicated power supply. Lower the forks and remove the load. Switch the truck off and connect the main power connector (Fig1,5) to the power supply.

The charger starts charging the battery. Charging is finished until the charging LED (Fig.16) produces permanent green light. The charger then goes into a floating mode to prevent the battery against damages. When charging is finished, disconnect the connector from the socket and place it in the designated pocket. Following table shows the function of the LED-status:

Table 4: LED-Status

LED- signal	Function
Red	Battery discharged
Orange	Charging
Green	Fully charged

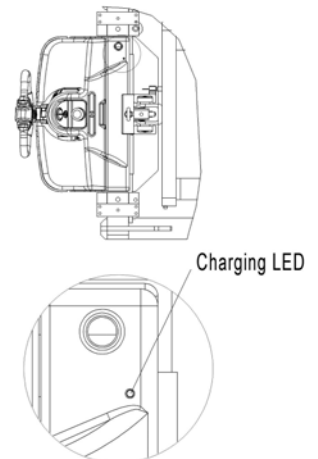

Fig.16: LED- Status

8. REGULAR MAINTENANCE



- Only qualified and trained personnel are allowed to do maintenance on this truck.
- Before maintaining, remove the load and lower the forks to the lowest position.
- If you need to lift the truck, follow chapter 4 b by using designated lashing or jacking equipment. Before working, put safety devices (for instance designated lift jacks, wedges or wooden blocks) under the truck to protect against accidental lowering, movement or slipping.
- Please pay attention by maintain the tiller arm. The gas pressure spring is pre-loaded by compression. Carelessness can cause injury.
- Use approved and from your dealer released original spare parts.
- Please consider that oil leakage of hydraulic fluid can cause failures and accidents.
- It is allowed to adjust the pressure valve only from trained service technicians.

If you need to change the wheels, please follow the instructions above. The castors must be round and they should have no abnormal abrasion.

Check the items emphasized maintenance checklist.

a. Maintenance checklist

Table 5: Maintenance checklist		Interval (Month)			
		1	3	6	12
Hydraulic					
1	Check the hydraulic cylinder, piston for damage noise and leakage		•		
2	Check the hydraulic joints and hose for damage and leakage		•		
3	Inspect the hydraulic oil level, refill if necessary		•		
4	Refill the hydraulic oil (12 month or 1500 working hours)				•
5	Check and adjust the function of the pressure valve (2200lbs +0/ +10%)				•
Mechanical system					
6	Inspect the forks for deformation and cracks		•		
7	Check the chassis for deformation and cracks		•		
8	Check if all screws are fixed		•		
9	Check mast and chain for corrosion, deformation or damages, replace if necessary	•			
10	Check the gearbox for noise and leakage		•		
11	Check the wheels for deformation and damages, replace if necessary		•		
12	Lubricate the steering bearing				•
13	Inspect and lubricate the pivot points		•		
14	Lubricate the grease nipples	•			
15	Replace the guarding and/or protective screen if it is damaged	•			
Electric system					
16	Inspect the electric wiring for damage		•		
17	Check the electric connections and terminals		•		
18	Test the Emergency switch function		•		
19	Check the electric drive motor for noise and damages		•		

20	Test the display		•		
21	Check if correct fuses are used, if necessary replace.		•		
22	Test the audio warning signal		•		
23	Check the contactors		•		
24	Check the frame leakage (insulation test)		•		
25	Check function and wear of the accelerator		•		
26	Check the electrical system of the drive motor		•		
Braking system					
27	Check brake performance, if necessary replace the brake disc or adjust the air gap		•		
Battery					
28	Check the battery voltage		•		
29	Clean and grease the terminals and check for corrosion and damage		•		
30	Check the battery housing for damages		•		
Charger					
31	Check the main power cable for damages			•	
32	Check the start-up protection during charging			•	
Function					
33	Test the audio warning signal	•			
34	Check the air gap of the electromagnetic brake	•			
35	Test the emergency braking	•			
36	Test the reverse and regenerative braking	•			
37	Test the safety (belly) button function	•			
38	Check the steering function	•			
39	Check the lifting and lowering function	•			
40	Check the tiller arm switch function	•			
41	Test the key switch of damages and function	•			
42	Test the speed limitation switch (lifting height >~11.8in)	•			
General					
43	Check if all decals are legible and complete	•			
44	Check if the protective screen and or guarding is not damaged	•			
45	Inspect the castor, adjust the height or replace it, if worn out		•		
46	Carry out a test run	•			

b. Lubricating points

Lubricate the marked points according to the maintenance checklist.

The required grease specification is: DIN 51825, standard grease.

- 1 Bearings in wheels
- 2 Main frame post
- 3 Chain
- 4 Hydraulic system
- 5 Steering bearing
- 6 Gear box

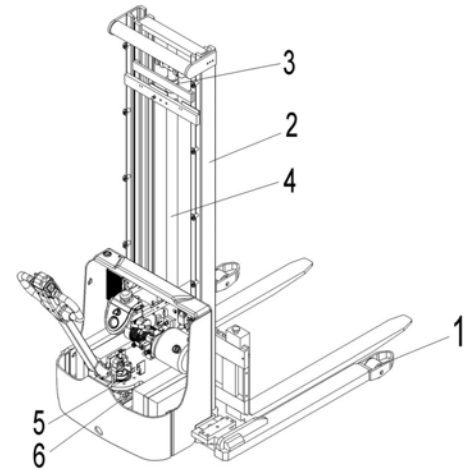

Fig.17: Lubricating points

c. Check and refill hydraulic oil

It is recommended to use hydraulic oil in connection with average temperature:

Environment temperature	-5°C~25°C	>25°C
Type	HVLP 32, DIN 51524	HLP 46, DIN 51524
Viscosity	28.8-35.2	41.4 - 47
Amount	3.0L(depends on specific model)	

Waste material like oil, used batteries or other must be probably disposed and recycled according to the national regulations and if necessary brought to a recycling company.

The oil level height shall be in the not lifted position min.9.3L to 9.5L.

If necessary add oil at the filling point.

d. Checking electrical fuses

Remove the main cover. The fuses are located according to Fig.18; the size is according to table 6

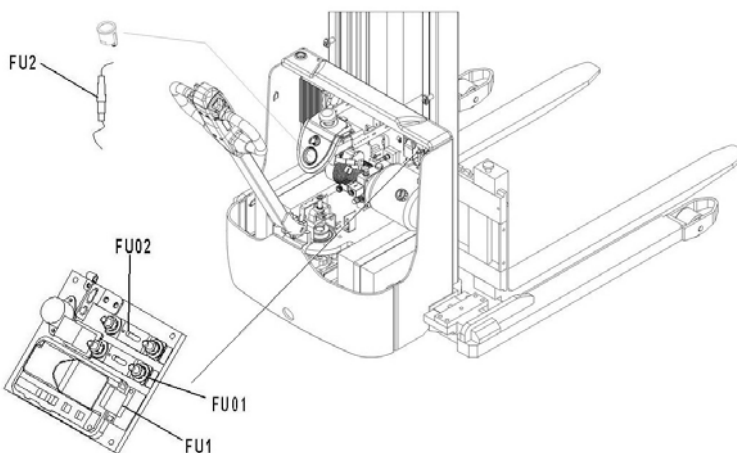

Table6: Size of the fuses

	Rate
FU1	10A
FU2	0.5A
FU 01	60A
FU 02	150A

Fig. 18: Location fuses

e. Removing, reattaching guarding



DO NOT USE THIS TRUCK, IF THE GUARDING IS DAMAGED OR NOT CORRECTLY ASSEMBLED!

If the guarding needs to be removed, unbolt the fixing screws and remove the screen carefully. The screws will remain with the screen. For reattaching place the screen to the right position and fix each screw correctly. If you need to replace parts, please call your next service partner.

9. TROUBLE SHOOTING



- If the truck has malfunctions follow the instructions, mentioned in chapter 6.

Table 7: Trouble shooting

TROUBLE	CAUSE	REPAIR
Load can't be lifted	Load weight too high	Lift only the max. capacity, mentioned on the ID-plate
	Battery discharged	Charge the battery
	Lifting fuse faulty	Check and eventually replace the lifting fuse
	Hydraulic oil level too low	Check and eventually refill hydraulic oil
	Oil leakage	Repair the hoses and/or the sealing of the cylinder
Oil leakage from air breathing	Excessive quantity of oil.	Reduce oil quantity.
Load can't be lowered	Dirty oil blocks control valve.	Check hydraulic oil and clean control valve. Replace the oil if necessary.
	The solenoid valve for lowering is not opened or is damaged.	Check or replace the valve for lowering.
Stacker not starts operating	Battery is charging	Charge the battery completely and then remove the main power plug from the electrical socket.
	Battery not connected	Connect the battery correctly
	The fuse is faulty	Check and eventually replace fuses
	Battery discharged	Charge the battery
	Combined emergency switch is activated	De-activate the combined emergency switch by insert and pull the knob.
	Tiller in the operating zone	Move the tiller firstly to the braking zone.
Only travelling in one direction	The accelerator and the connections are damaged.	Check the accelerator and the connections.
The stacker only travels very slowly	The battery is discharged.	Check the battery status at the discharge indicator

	The electromagnetic brake is engaged.	Check the electromagnetic brake
	The relating tiller cables are disconnected or damaged	Check the tiller cables and connections.
The stacker starts up suddenly	The controller is damaged.	Replace the controller.
	The accelerator not moves back to its neutral position.	Repair or replace the accelerator.

If the truck has malfunctions and can't be operated out of the working zone, jack the truck up and go with a load handler under the truck and safe the truck securely. Then move the truck out of the aisle.

10. WIRING/ CIRCUIT DIAGRAM

a. Electrical circuit diagram

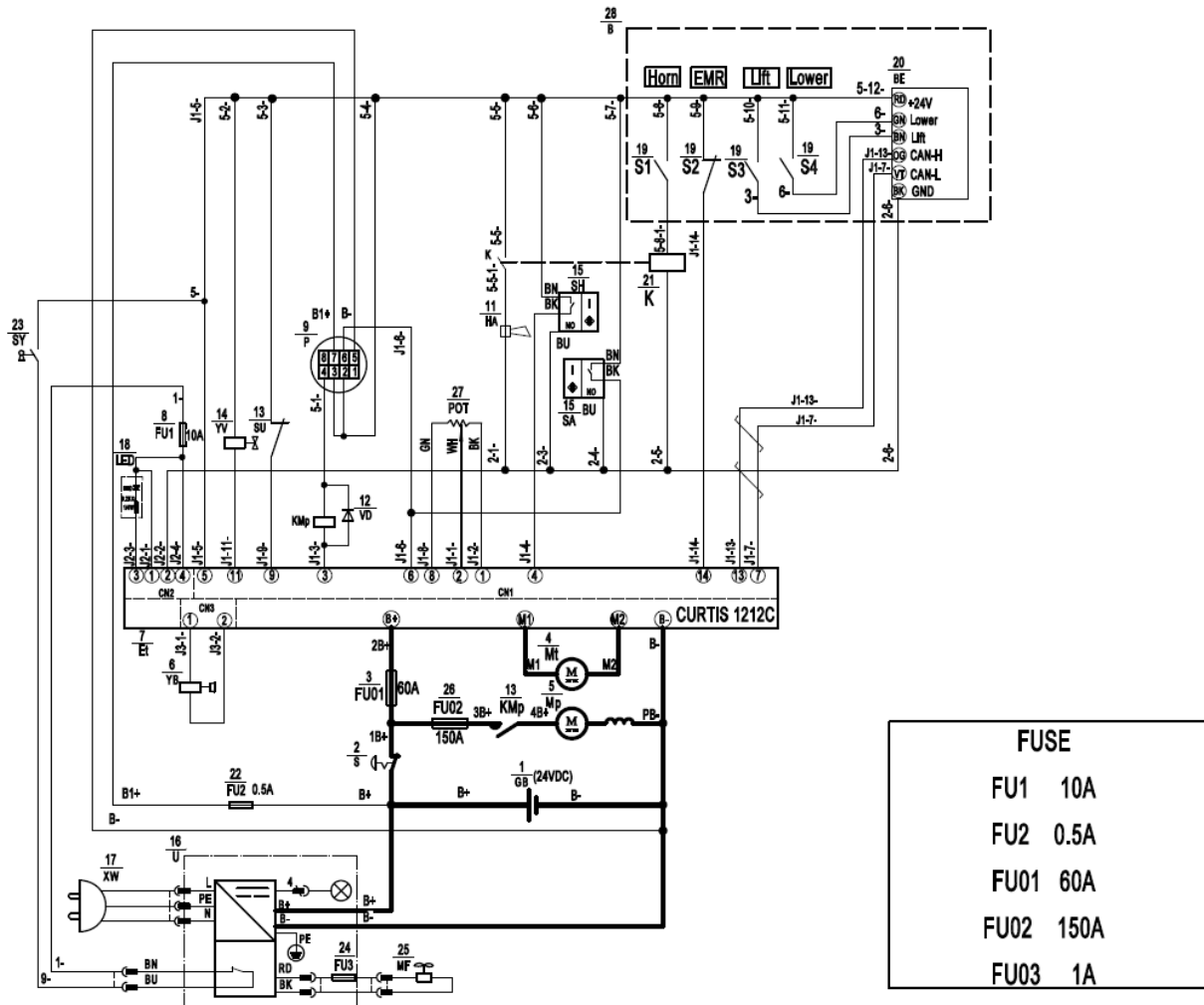

Fig. 19: Electric diagram

Table 7: Description of electrical diagram

Code	Item	Code	Item
GB	Battery	SA, SH	Proximity switch

S	Emergency button	U	Charger
FU01	Fuse 60A	XW	Spring cord
Mt	Traction motor	LED	Fault display
Mp	Pump motor	S1、S2、S3、S4	Switch
YB	Electromagnetic brake	BE	Accelerator
Et	Traction controller	K	Relay
FU1	Fuse 10A	FU2	Fuse tube (0.5A)
P	Indicator	SY	Key switch
HA	Horn	FU3	Fuse 1A
VD	Diode	MF	Fan
KMp	Pump contactor	FU02	Fuse 150A
SU	Limit switch	POT	Potentiometer
YV	Electromagnetic valve	B	Tiller

b. Hydraulic circuit

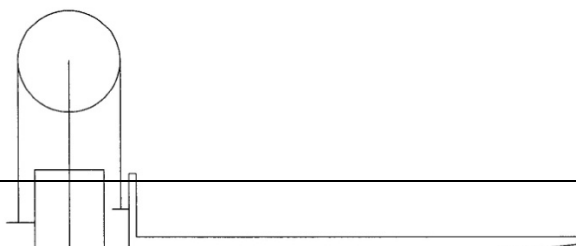

Fig. 20:Hydraulic circuit