

INSTRUCTION HANDBOOK

Electric Stacker PS26/35/40TSL

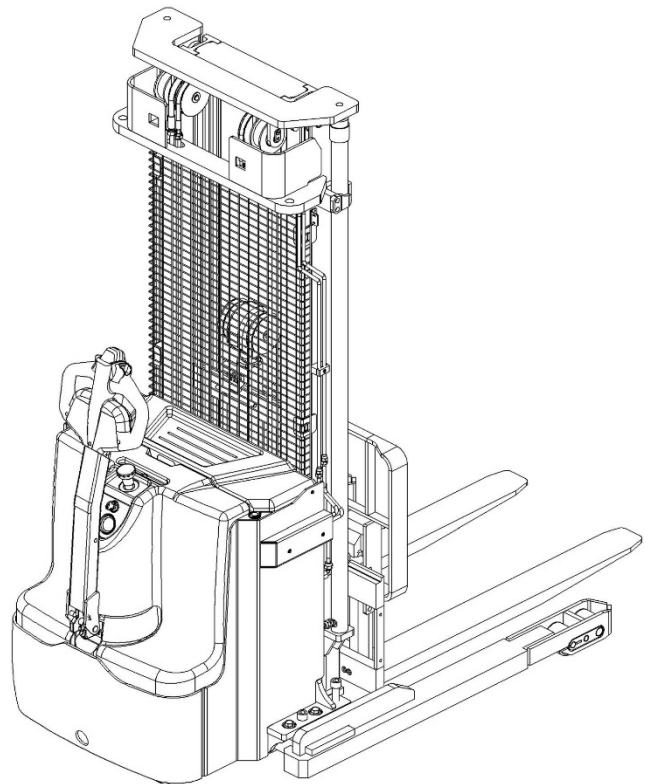

WARNING

Do not use the electric truck before reading and understanding these operating instructions.

NOTE:

- Please check the designation of your present type at the last page of this document as well as on the ID-plate.
- Keep for future reference.

Version 05/2018

PS26/35/40TSL-SMS-001-EN

FOREWARD

Before operating the electric stacker, read this ORIGINAL INSTRUCTION HANDBOOK carefully and understand the usage of the truck completely. Improper operation of the truck may create a danger situation. This handbook describes the usage of different electric stackers. When operating and servicing the truck, make sure, that it applies to your type.

Keep this handbook for future reference. If this or the warning/caution labels are damaged or got lost, please contact your local dealer for replacement.

This truck complies with the requirements according to EN 3691-1 (Industrial trucks - safety requirements and verification, part 1), EN 12895 (Industrial trucks - electromagnetic compatibility), EN 12053 (Safety of industrial trucks- test methods for measuring noise emissions), EN 1175-1 (Industrial truck safety – electrical requirements), assumed the truck is used according to the described purpose.

The noise level for this machine is < 70 dB(A) according to EN 12053.

The vibration is 0,85 m/s² (if equipped with a platform) according to EN 13059.

ATTENTION:

- Environmentally hazardous waste, such as batteries, oil and electronics, will have a negative effect on the environment or health, if handled incorrectly.
- The waste packages should be sorted and put into solid dustbins according to the materials and be collected disposal by local special environment protection bureau. To avoid pollution, it's forbidden to throw away the wastes randomly.
- To avoid leaking during the use of the products, the user should prepare some absorbable materials (scraps of wooden or dry duster cloth) to absorb the leaking oil in time. To avoid second pollution to the environment, the used absorbable materials should be handed in to special departments in terms of local authorities.
- Our products are subject to ongoing developments. The information written in this handbook is provided as reference for operating and servicing the stacker and may vary in terms of description of particular features of the truck.



NOTE: On this manual, the left sign means warning and danger, which can lead to death or serious injury if not followed.

Copyright

The copyright remains with the company, mentioned on the CE- certificate at the end of this document or, if sold within the USA, with the company, mentioned on the company sticker.

TABLE OF CONTENTS

1. CORRECT APPLICATION	4
2. DESCRIPTION OF THE STACKER.....	5
a. Overview of the main components	5
b. Main technical data	5
c. Description of the safety devices and warning labels (USA).....	8
d. Identification plate	8
3. WARNINGS, RESIDUAL RISK AND SAFETY INSTRUCTIONS	9
4. COMMISSIONING, TRANSPORTING, DECOMMISSIONING.....	10
a. Commissioning	10
b. Lifting/transportation	10
c. Decommissioning.....	11
5. DAILY INSPECTION.....	11
6. OPERATING INSTRUCTIONS	12
a. Parking	12
b. Residual lift diagram(without side shift)	12
c. Residual lift diagram(with side shift)	12
d. Lifting.....	13
e. Lowering.....	13
f. Side shift (option)	13
g. Travelling.....	13
h. Steering.....	14
i. Braking	14
j. Malfunctions	15
k. Emergency	15
l. Fork adjustment	15
m. Fork replacement	16
n. Leg adjustment	16
7. BATTERY CHANGING AND REPLACEMENT	17
a. Replacement.....	17
b. Battery indicator	18
c. Charging.....	18
8. REGULAR MAINTENANCE	18
a. Maintenance checklist.....	19
b. Lubricating points.....	20
c. Check and refill hydraulic oil	21
d. Checking electrical fuses	21
e. Removing, reattaching guarding.....	21
9. TROUBLE SHOOTING	22
10. WIRING/ CIRCUIT DIAGRAM.....	24
a. Electrical circuit diagram	24
b. Hydraulic circuit(with side shift)	26

c. Hydraulic circuit(without side shift)27

1. CORRECT APPLICATION

It is only allowed to use this electric stacker according to this instruction handbook.

The in this handbook described trucks are self propelled pedestrian controlled electric power stacker, with electrically operated lifting function. The trucks are designed for stacking operations in dedicated racking by lifting and lowering the palletized load up to the desired lifting height.

A wrong usage can cause human injuries or can damage equipment.

The operator/ the operating company has to ensure the correct usage and has to ensure, that this truck is used only by staff, which is trained and authorized to use this truck.

The truck has to be used on substantially firm, smooth, prepared, level and adequate surfaces. The truck is intended to be used for indoor applications with ambient temperatures between +5°C and + 40°C and for light duty applications without crossing permanent obstacles or potholes. Operating on ramps is not allowed. While operating, the load must be placed approximately on the longitudinal centre plane of the stacker. Lifting or transporting people is forbidden. If travelling the load must be lowered to the lifting point.

It is not allowed to use this truck on tail lifts or loading ramps.

The capacity is marked on the load diagram as well on the Identification plate. The operator has to consider the warnings and safety instructions. Operating lighting must be minimum 50 Lux.

Modification

No modifications or alterations to this truck which may affect, for example, capacity, stability or safety requirements of the truck, shall be made without the prior written approval of the original truck manufacturer, its authorized representative, or a successor thereof. This includes changes affecting, for example braking, steering, visibility and the addition of removable attachments. When the manufacturer or its successor approve a modification or alteration, they shall also make and approve appropriate changes to capacity plate, decals, tags and operation and maintenance handbooks.

By not observing these instructions, the warranty becomes void.

2. DESCRIPTION OF THE STACKER

a. Overview of the main components

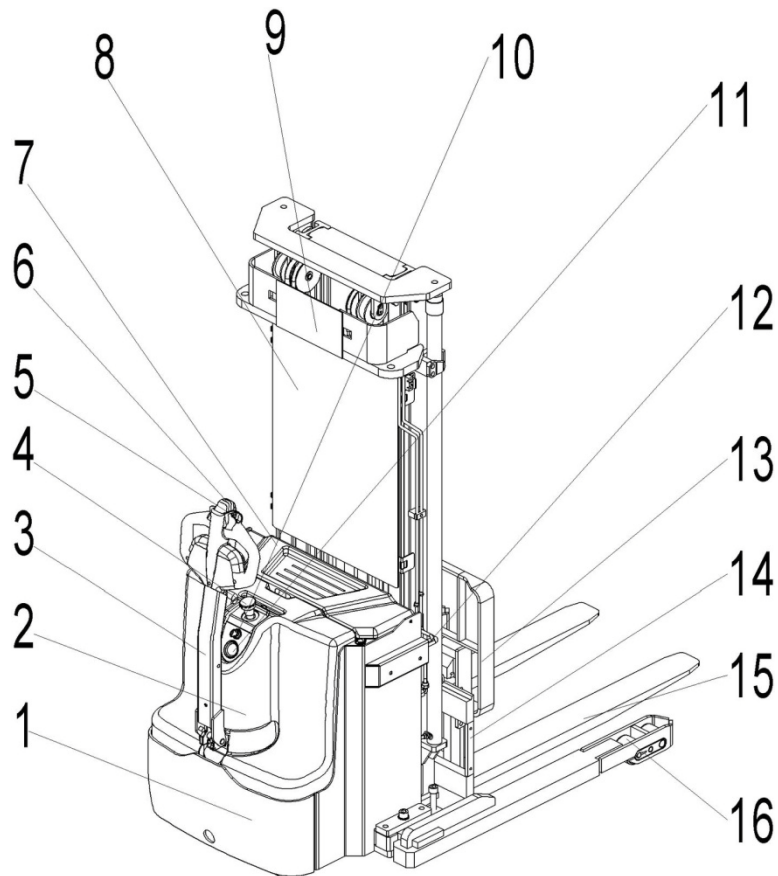

Fig. 1: Overview main components

- | | |
|---------------------|-------------------------------|
| 1. Chassis | 9. Mast |
| 2. Main cover | 10. Key switch |
| 3. Tiller | 11. Indicator |
| 4. Emergency switch | 12. Hydraulic system assembly |
| 5. Belly button | 13. Load backrest |
| 6. Accelerator | 14. fork carriage |
| 7. Battery cover | 15. Fork |
| 8. Protective mesh | 16. Load roller assembly |

b. Main technical data

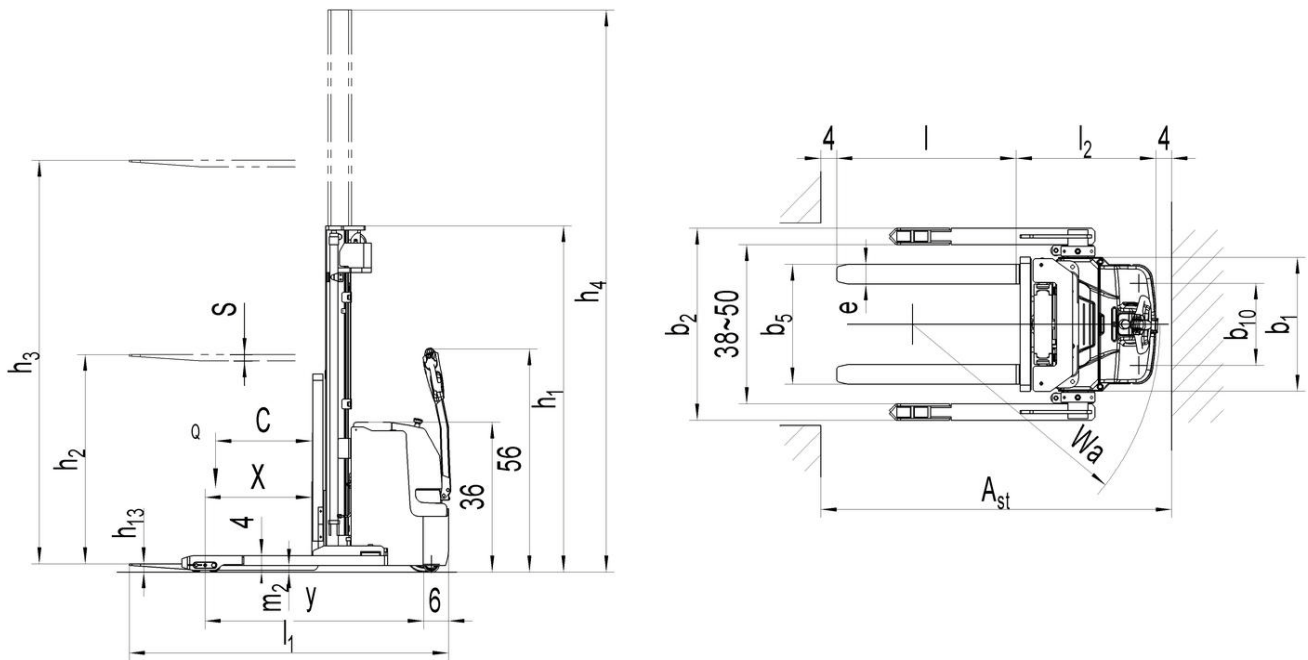

Fig. 2: Technical data

Table 1: Main technical data for standard version

Type sheet for industrial truck acc. to VDI 2198						
Distinguishing mark	1.2	Manufacturer's type designation		PS26T SL(142)	PS35TSL (181)	PS40T SL(181)
	1.3	Power (battery ,diesel, petrol, gas, manual)		Battery		
	1.4	Operator type		Pedestrian		
	1.5	Load Capacity / rated load	Q(lbs)	2640	3520	3960
	1.6	Load centre distance	C(in)	23.6	23.6 ¹⁾	
	1.8	Load distance ,centre of drive axle to fork	x(in)	25.5	26.1 ²⁾	25.5 ²⁾
	1.9	Wheelbase	y(in)	52.4	54.3	54.3
Weight	2.1	Service weight	lbs	2623.5	3262.8	3439.2
	2.2	Axle loading, laden front/rear	lbs	1706.4/3523	1823.2/4967	1966.5/5242.6
	2.3	Axle loading, unladen front/rear	lbs	1755/868.6	1904.8/1358	2037/1402
Tires, chassis	3.1	Tires		Polyurethane (PU)		
	3.2	Tire size, front	ØxW (in)	Ø9x2.8		
	3.3	Tire size, rear	ØxW (in)	Ø3.3x2.8		
	3.4	Additional wheels(dimensions)	ØxW (in)	Ø4x1.6		
	3.5	Wheels, number front/rear(x=driven wheels)		1x+2/4		
	3.6	Track, front	b10(in)	19.7		
Dimensions	4.2	Lowered mast height	h1(in)	91	83	87.7
	4.3	Free Lift height	h2(in)	69.3	60	60
	4.4	Lift height	h3(in)	140	178.3	178.3

	4.5	Extended mast height	h4(in)	161	200.3	205
	4.9	Height of tiller in drive position min./ max.	h14(in)	35/56		
	4.15	Height, lowered	h13(in)	2		
	4.19	Overall length	l1(in)	78.3	82	82.4
	4.20	Length to face of forks	l2(in)	33	36.4	37
	4.21	Overall width	b1/b2(in)	32.1/46-58		
	4.22	Fork dimensions	s/e/l(in)	1.4x4x45.3	1.6x4.7x45.3	
	4.25	Width across forks	b5(in)	9.3-28	10-28.7	
	4.32	Ground clearance, centre of wheelbase	m2(in)	1.6		
	4.33	Aisle width for pallets 1000X1200 crossways	Ast(in)	94.3	96	96.3
	4.34	Aisle width for pallets 800X1200 lengthways	Ast(in)	93.8	95.2	95.7
	4.35	Turning radius	Wa(in)	59	61	61
Performance data	5.1	Travel speed, laden/ unladen	mph	3.4/3.7	3.4/3.7	3.4/3.7
	5.2	Lift speed, laden/ unladen	fpm	17.72/27.56	25.59/35.43	25.59/35.43
	5.3	Lowering speed, laden/ unladen	fpm	49.21/39.37	39.37/27.56	39.37/27.56
	5.8	Max. gradeability, laden/ unladen	%	6/12	6/12	6/10
	5.10	Service brake		Electromagnetic		
Electric- engine	6.1	Drive motor rating S2 60min	HP	1.74	1.88	1.88
	6.2	Lift motor rating at S3 10%	HP	2.01	4.29	4.29
	6.3	Battery acc. to DIN 43531/35/36 A, B, C, no		2PZB	3VBS	3VBS
	6.4	Battery voltage, nominal capacity K5	V/Ah	24/180	24/270	24/270
	6.5	Battery weight	lbs	386	507	507
	6.6	Energy consumption acc: to VDI cycle	kWh/h	0.95	1.59	1.70
Additional data	8.1	Type of drive control		AC- speed control		
	8.4	Sound level at driver`s ear acc. to EN 12053	dB(A)	<70		

Note: 1) with side shift, load centre distance is 19.7 inch

2) with side shift, load distance is 2.2 inch shorter

Table 2: Mast

Designation	Lowered mast height h1(in)	Free Lift height h2(in)	Lift height h3(in)	Extended mast height h4(in)	Lift+fork height h3+h13(in)
PS26TSL					
Two stage mast	77	-	111	133	113
	83	-	123	145	125
	91	-	139	161	141
Two stage mast FFL (Full-Free-Lift)	77	55.5	111	133	113
	83	61.4	123	145	125
	91	69.3	139	161	141
PS35TSL					
Two stage mast	77	—	111	133	113
	83	—	123	145	125
	91	—	139	161	141
Two stage mast FFL (Full-Free-Lift)	77	55.5	111	133	113
	83	61.4	123	145	125
	91	69.3	139	161	141
Three stage mast	79	—	167	188	169
	83	—	178	200	180
Three stage mast FFL (Full-Free-Lift)	75	52	155	176	157
	79	55.9	167	188	169
	83	59.8	178	200	180
	92	69	206	227.6	207.9
PS40TSL					
Two stage mast	82	—	111	138	113
	88	—	123	150	125
	96	—	139	165	141
Two stage mast FFL (Full-Free-Lift)	78	51.6	104	130	106
	82	55.5	111	138	113
	88	61.4	123	150	125
	96	69.3	139	165	141
Three stage mast	84	—	167	193	169
	88	—	178	205	180
Three stage mast FFL (Full-Free-Lift)	78	51.6	155	181	157
	84	55.9	167	193	169
	88	59.8	178	205	180

c. Description of the safety devices and warning labels (USA)

- A. Crane hook label
- C. Residual lift capacity sticker
- E. Identification plate (ID-plate)
- F. Sticker to read and follow these instructions
- G. Sign oil filling point
- H. Sign danger not riding
 - I. Sign danger being crushed
- J. Sign warning stay clear stop truck
- L. Sign danger battery
- M. Sign warning electrical devices
- N. Sign not under, on forks

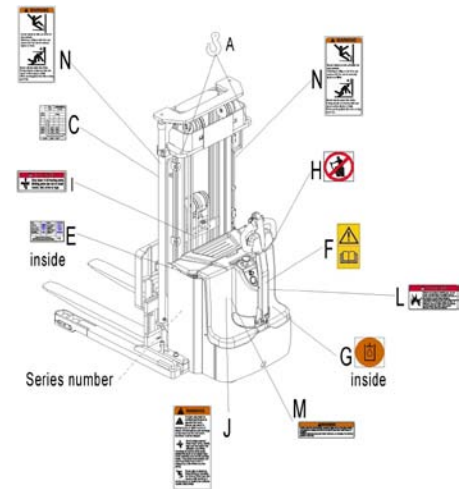

Fig. 3: Warning labels and safety devices

The truck has an emergency button (4) which stops all lifting-, lowering-, driving- functions and engages the failsafe electromagnetic brake when it is pushed. By pulling this button, the truck can be operated after the controller checked the functions. Before operating, insert the key and turn the switch (10) clockwise. To prevent against unauthorized access, turn the key anti-clockwise and remove it if you do not operate this truck. The truck is equipped with a safety (belly) button (5) which switches the driving function away from the operator, if the truck travels towards the operator and the tiller is in its operating zone. Follow also the instructions given on the decals. Replace the decals if they are damaged or missing.

d. Identification plate

- | | | | |
|---|--|----|-----------------------------------|
| 1 | Designation, type | 6 | Name and address of manufacturer) |
| 2 | Serial number | 7 | Battery weight minimum/ maximum |
| 3 | Rated capacity in kg | 8 | Nominal power in kW |
| 4 | Supply voltage in V | 9 | Load center distance |
| 5 | Own mass (self weight) in kg without battery | 10 | Manufacturing data |
| | | 11 | Option |

1	Type	xxx xx	Option	xx X xxxx	
2	Serial No.	xxxxx	Year of Manuf.	MM/YYYY	
3	Rated capacity	xxxx kg	Load center distance	xxx mm	11
4	System voltage	xx V	Nominal power	xx kW	10
5	Net weight without battery	xxx kg	Battery mass min/max	xxx / xxx kg	9
					8
6	XXXX XXXX XXXXXXXX xx XXXXX / XXXXXX			CE	7

If sold to the EU, here the place of the CE marking

Fig. 4: Identification plate

3. WARNINGS, RESIDUAL RISK AND SAFETY INSTRUCTIONS



DO NOT

- Drive outside the stacking operation with a lifted load higher than the lifting point.
- Put foot or hand under or into the lifting mechanism.
- Allow other person than the operator to stand in front of or behind the truck when it is moving or lifting/lowering.
- Overload the truck.
- Put foot in front of the wheels, injury could result.
- Lift people. People could fall down and suffer severe injury.
- Push or pull loads.
- Use this truck on ramps.
- Use the truck without a removed protective screen
- locate load at side or end of forks. Load must be distributed evenly on the forks.
- Use the truck with unstable or unbalanced load.
- Use the truck without manufacturer's written consent.
- Supply on board charger with AC voltage other than 100V or 240V.

Watch difference in floor levels when driving. Load could fall down or the truck could get uncontrollable. Keep watching the condition of load. Stop operating the truck if load becomes unstable. Brake the truck and activate the emergency button (4) by pushing when sliding load on or off the truck. If the truck has any malfunctions, follow chapter 10.

Practice maintenance work according to regular inspection. This truck is not designed to be water resistant. Use the truck under dry condition. Prolonged continuous operation might cause damage of the power pack. Stop operation if temperature of hydraulic oil is too high.



- When operating the truck, the operator has to wear safety shoes.
- The truck is intended to be used for indoor applications with ambient temperatures between +5°C and + 40°C.
- The operating lighting must be minimum 50 Lux.
- It is not allowed to use the truck on ramps.
- To prevent unintended sudden movements when not operating the truck (i.e. from another person, etc.). Switch of the truck and remove the key.

4. COMMISSIONING, TRANSPORTING, DECOMMISSIONING

a. Commissioning

Table 3: Commissioning data

Type	PS26TSL / 142	PS35TSL / 181	PS40TSL / 181
Commissioning weight [lbs]	2454	2811	2987
Version/ Lift [in]	142	181	181

After receiving our new truck or for re-commissioning you have to do following before (firstly) operating the truck:

- Check if are all parts included and not damaged
- Install and charge the battery (follow chapter 8)
- Do the work according to the daily inspections as well as functional checks.

b. Lifting/transportation

For transporting, remove the load, lower the forks to the lowest position and fix the truck safe with dedicated lifting gear according to Fig. 5.

Lifting



**USE DEDICATED CRANE AND LIFTING EQUIPMENT
DO NOT STAND UNDER THE SWAYING LOAD
DO NOT WALK INTO THE HAZARDOUS AREA
DURING LIFTING**

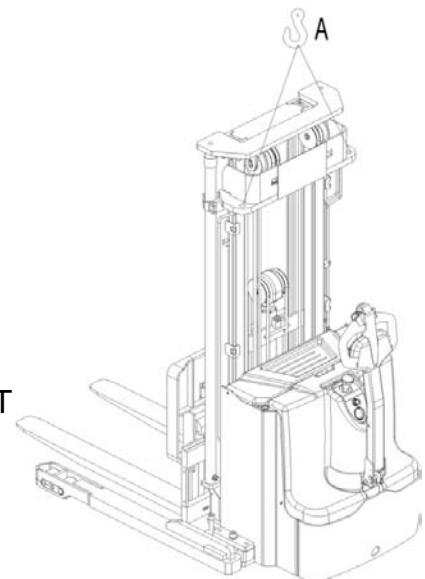

Fig.5: Lifting with a crane

Lower the forks and park the truck securely.
Fasten the truck according to Fig. 6 by fixing dedicated lashing belts to each side of the truck's crane hook holes and fasten the other side at the transporting truck.

Transportation



DURING TRANSPORTATION ON A LORRY OR TRUCK, ALWAYS FASTEN THE TRUCK SECURELY.

Lower the forks and park the truck on the metal plate securely. Fix the forks by the metal plank with two screws to the bottom metal plate. Fasten the truck by dedicated lashing belts according to Fig. 6 and fasten the other side at the transporting truck.

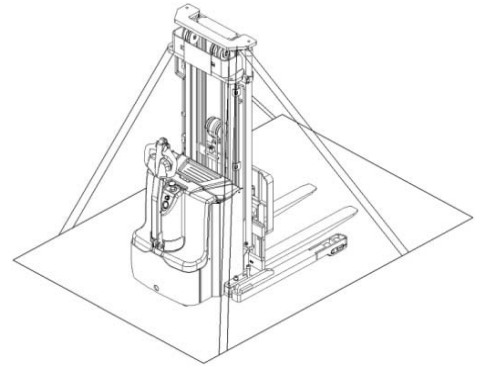

Fig. 6: Fixing points

C. Decommissioning

For storage, remove the load, lower the truck to the lowest position, grease all in this handbook mentioned greasing points (regular inspection) protecting the truck against corrosion and dust. Remove the batteries and jack the truck safely, so that there will be no flattening of wheels after storage.

For final decommissioning hand the truck to a designated recycling company. Oil, batteries and electric components must be recycled due to legal regulations.

5. DAILY INSPECTION

This chapter describes pre-shift checks before putting the truck into operation.

Daily inspection is effective to find the malfunction or fault on this truck. Check the truck on the following points before operation.



**Remove load from truck and lower the forks.
DO NOT USE THE TRUCK IF ANY MALFUNCTION IS FOUND.**

- Check for scratches, deformation or cracks.
- Check if there is any oil leakage from the cylinder.
- Check the vertical creep of the truck.
- Check the chain and rollers for damages or corrosion.
- Check the smooth movement of the wheels.
- Check the function of the emergency brake by activating the emergency button.
- Check, the tiller arm- switch braking function
- Check the lifting and lowering functions by operating the buttons.
- Check if the protective screen has no damages and that is correctly assembled.
- Check the audio warning signal.
- Check if all bolts and nuts are tightened firmly.
- Check the function of the key switch.
- Check the speed limitation switch.
- Visual check if there are any broken hoses or broken electric wires.
- If supplied with a backrest extension, check it for damages and correct assembling.

6. OPERATING INSTRUCTIONS



BEFORE OPERATING THIS TRUCK, PLEASE FOLLOW THE WARNINGS AND SAFETY INSTRUCTIONS (CHAPTER 3).

BEFORE OPERATING THIS TRUCK, ENSURE THAT THE LOAD OR OTHER EQUIPMENT NOT CAUSES INSUFFICIENT VISIBILITY!

Make sure, that the load is palletized and stable and that the daily inspection is carried out. For starting, insert the key and turn it clockwise to the “ON”- position. The key can be used only used on pedestrian controlled power stacker. Eventually before inserting the key, the emergency button must be pulled carefully.

Press the horn button (22) to activate the audible warning signal.

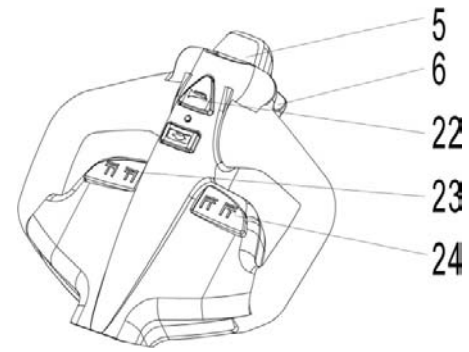

Fig.7: Tiller operating controls

a. Parking



DO NOT PARK THE TRUCK ON INCLINED SURFACES

The truck is equipped with an electromagnetic failsafe stopping and parking brake.

Always lower the forks fully and drive the truck to a safe area. Turn the key anti- clockwise to the “Off” – position and remove the key.

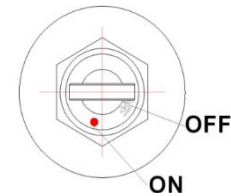

Fig. 8: Key switch

b. Residual lift diagram(without side shift)

The residual lift diagram indicates the maximum capacity Q [lbs] for a given load centre c [in] and the corresponding lift height H [in] for the truck with horizontal load.

The white markings on the mast indicate if the specific lifting limits reached. For instance with a load centre of gravity distance c of 24in and a maximum lift height H of 181 in, the max. capacity Q is 1764lbs.

Type	PS35TSL	
Mast	181	

h3 (in)	Q (lbs)	
	23.6	27.6
181	1764	1102
169	1984	1323
142	2205	1543
126	2646	1984
114	3086	2425
98	3527	2646

Fig. 9: Residual lift diagram (without side shift)

c. Residual lift diagram(with side shift)

The residual lift diagram indicates the maximum capacity Q [lbs] for a given load centre c [in] and the corresponding lift height H [in] for the truck with horizontal load.

The white markings on the mast indicate if the specific lifting limits reached. For instance with a load centre of gravity distance c of 20in and a maximum lift height H of 181in, the max. capacity Q is 1543lbs.

Type	PS35TSL
Mast	181

h3 (in)	Q (lbs)	
	19.7	23.6
181	1543	882
169	1764	1102
142	1984	1323
126	2425	1764
114	2866	2205
98	3527	2646

d. Lifting



DO NOT OVERLOAD THE TRUCK! THE MAXIMUM CAPACITY IS 2600/3500/4000 lbs LIFT ONLY CAPACITIES ACCORDING TO THE RESIDUAL LIFT DIAGRAM.

Travel with the lowered forks fully underneath the pallet and press the lifting button (Fig. 7, 24) until you reached the desired lifting height.

Fig. 10: Residual lift diagram (with side shift)

e. Lowering

If the forks are in the racking, firstly travel out of the racking carefully with or without the pallet. By travelling out of the racking, take care that the forks are not touching the racking. Press the lowering button (Fig. 7, 24) carefully. Lower the load until the forks are clear of the pallet, then drive the truck carefully out of the load unit.

f. Side shift (option)

After truck is stopped, press the side shift button (Fig. 7, 23) until you reached the desired position.

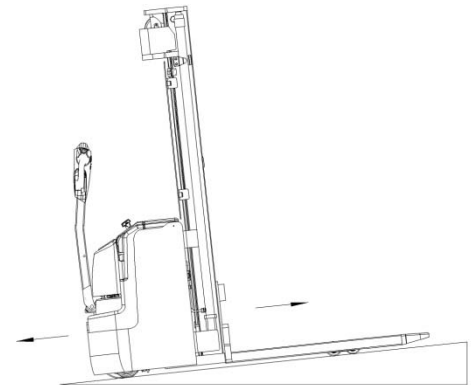

Fig.11: Load facing uphill

g. Travelling

TRAVEL ON INCLINES ONLY WITH THE LOAD FACING UPHILL.



DO NOT TRAVEL ON INCLINES MORE THAN SPECIFIED WITH THE TECHNICAL DATA.

TRAVELLING IS ONLY ALLOWED IF THE FORKS ARE LOWERED DOWN TO THE LIFTING POINT (<118in).

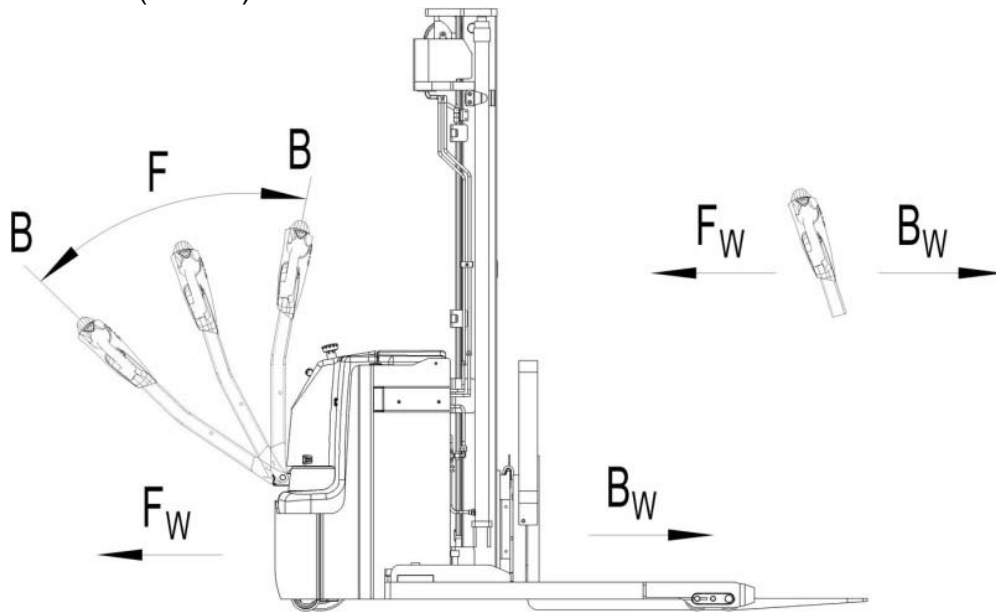

Fig.12: Operating direction

After starting the truck by turning the inserted key to the “ON”- position (Fig. 8) and eventually by pulling the emergency button carefully, move the tiller to the operating zone ('F', Fig.12).

Turn the accelerator button to the desired direction forward 'Fw.' Or backwards 'Bw.'(Fig.12).

Control the travelling speed by moving the accelerator button carefully until you reached the desired speed.

If you move the accelerator button back to the neutral position, the controller decelerates the truck until the truck stops. If the truck stops, the parking brake will be engaged.

Drive carefully the truck to the destination. Watch the route conditions and adjust the travelling speed with the accelerator- button.

h. Steering

You steer the truck by moving the tiller to the left or right side.

i. Braking



THE BRAKING PERFORMANCE DEPENDS ONT THE TRACK CONDITONS AND THE LOAD CONDITONS OF THE TRUCK

The braking function can be activated on several ways:

- By moving the accelerator button (6) back to the initial '0' position or by releasing the button, the regenerative braking is activated. The truck brakes until it stops.
- By moving the accelerator button (6) from one driving direction directly to the opposite direction, the truck brakes regenerative until it starts travelling into the opposite direction.
- The truck brakes, if the tiller is moved up or down to the braking zones ('B'). If the tiller is released, the tiller moves automatically up to the upper braking zone ('B'). The truck brakes until it stops.
- The safety (belly) button (5) prevents the operator from being crushed. If this button is activated, the truck decelerates and/ or starts travelling into the backwards direction ('Bw.') for a short distance and stops. Please consider, that this button also operates, if the truck is not travelling and the tiller is in the operating zone.

j. Malfunctions

If there are any malfunctions or the truck is inoperative, please stop using the truck and activate the emergency button (4) by pushing it. If possible, park the truck on a safe area, turn the key switch (10) anti- clockwise and remove the key.

Inform immediately the manager and, or call your service. If necessary, tow the truck out of the operating area by using dedicated lifting equipment.

k. Emergency

In emergencies, push the emergency button (4). All electrical functions will be stopped. Keep safe distance.

l. Fork adjustment



- Not fixed and improperly adjusted forks can lead to dangerous accidents.
- Check if the safety bolt (10) is installed before adjusting the forks. If the safety bolt (10) is not in place, the truck shall be prohibited to use.
- When adjusting the fork, pay attention that the distance between each fork and outer edge of the holder should be same.
- Clip the positioning pin into a fixing slot to avoid accidental movement of the fork.
- Load center must be located in the middle of the two forks.

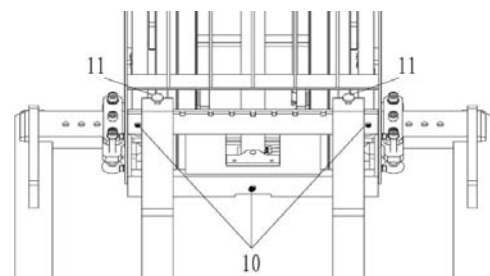

Fig. 13: Fork adjustment

Operation steps:

- Park the truck securely according to the regulations.
- Pulled up the positioning pin (13), make it away from the fixed slot.
- Move the forks (14) to the appropriate position.

In order to ensure the operation safety of picking process, the distance between the forks (14) should be as large as possible, and the fork position must be symmetrical with the center line of the fork holder. Load center must be located in the center of the forks (14).

- Put down the positioning pin (13), move the forks until the positioning pin clip into the fixing slot.

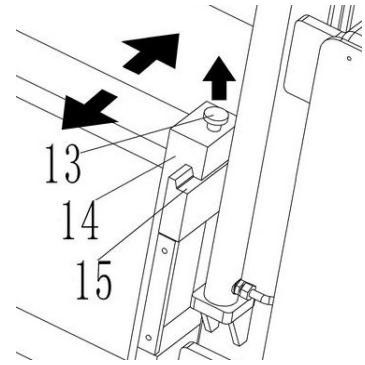

Fig.14: Move the forks

m. Fork replacement



- There is leg injury risk when replacing the forks.
- It's forbidden to pull the fork to the direction of the operator.
- Move the fork in the direction away from the operator.
- In order to prevent moving down, please use crane to fix heavy forks.
- Install the safety bolt (10) after replacing the fork and check whether the position of the safety bolt is correct.
- There is leg injury risk when replacing the forks.
- It's forbidden to pull the fork to the direction of the operator.

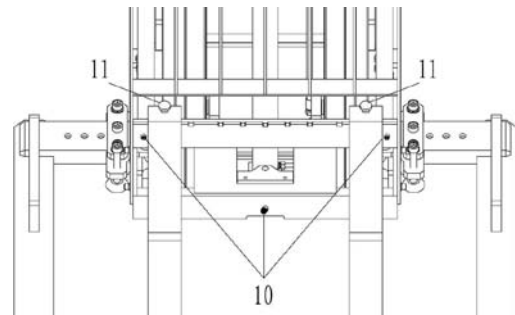

Fig.15: Replace the forks

Operation steps:

- Remove the safety bolt (10).
- Release fork positioning device (11).
- Move the forks to the center of fork holder and remove the forks through the groove.

n. Leg adjustment



- Not fixed and not properly adjusted legs can lead to dangerous accidents.
- There is leg injury risk when adjusting the legs.
- Tighten the positioning bolt (23) after adjusting the legs.
- When adjusting the legs, please pay attention that the number of positioning holes (21) exposed on each side of the legs should be same. (as shown in Fig. 16, if one side has 3 positioning holes(21), the other side should also be 3).

Operation steps:

- Park the truck securely according to the regulations.
- Turn clockwise the supporting assembly(20) on both sides of the truck until jacking up the truck.
- Remove locating bolt (23) and lock bolt (24).

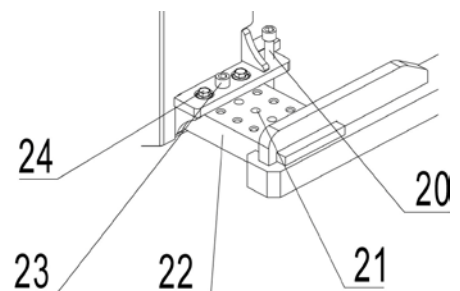

Fig.16: Adjust the legs

→ Adjust the leg (22) until the corresponding positioning hole (21) is adjusted to the under face of the positioning bolts (23).

When adjusting the legs, please pay attention that the number of positioning holes (21) exposed on each side of the legs should be same. (as shown in Fig. 16, if one side has 3 positioning holes(21), the other side should also be 3).

→ Tighten locating bolt (23) and lock bolt (24).

→ Turn anti-clockwise the supporting assembly (20) on both sides of the truck until the supporting assembly can't be turned anymore.

7. BATTERY CHANGING AND REPLACEMENT



- Only qualified personnel are allowed to service or charge the batteries. The instructions of this handbook and from the battery- manufacturer must be observed.
- These batteries are maintenance free; re- filling is prohibited.
- Recycling of batteries undergoes national regulations. Please follow these regulations.
- By handling batteries, open fire is prohibited, gases could cause explosion!
- In the area of battery charging neither burning materials nor burning liquids are allowed. Smoking is prohibited and the area must be ventilated.
- Park the truck securely before starting charging or installing/changing the batteries
- Before finishing the maintenance work, make sure, that all cables are connected correctly and that there are no disturbing towards other components of the truck.

The truck is equipped with following sealed liquid acid batteries:

PS26TSL 1 pc 2PzB 24V/ 180 Ah (C5) [660 x 146 x 657 (LxWxH)]

PS35TSL/PS40TSL 1 pc 3VBS 24V/ 270 Ah (C5) [752x172x657 (LxWxH)]



IT IS ONLY ALLOWED TO USE SEALED LIQUID ACID BATTERIES.

THE WEIGHT OF THE BATTERIES HAS AN INFLUENCE TO THE TRUCKS OPERATING BEHAVIOR.

PLEASE CONSIDER THE MAXIMUM OPERATING TEMPERATURE OF THE BATTERIES.

a. Replacement

Park the truck securely and switch off the stacker with the key (10) and activate the emergency button (4). Open the battery cover, pull out the hinge and remove the battery cover. Remove the battery block with the screw, disconnect battery plug and take the battery out with a crane.

The installation is in the reverse order of the removal. Please connect the positive terminals firstly. Otherwise the tuck could be damaged.

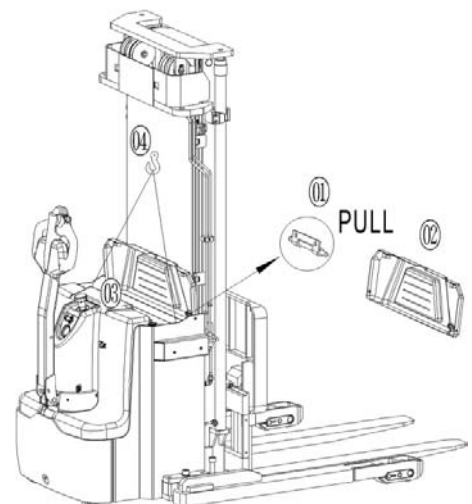

Fig. 17: battery replacement

b. Battery indicator

The discharge status is indicated by ten red LED segments.

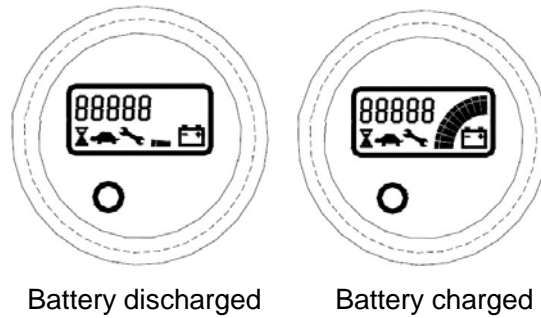

Fig.18: Battery discharge indicator

Only when the battery is properly charged, the most right LED lit. As the battery's state-of-charge decreases, successive LEDs light up, only one on at a time.

- The 2nd from left LED flashes, indicating “energy reserve” (70% depth of discharge).
- The 2 most left LEDs alternately flash, indicating “empty” (80% depth of discharge).

c. Charging



- Before using the charger, please fully understand the instructions of the charger instructions.
- Always follow these instructions!
- The room, where you are charging must be ventilated.
- The exactly charge status can be only checked from the discharge indicator. To control the status, the charging must be interrupted and the truck must be started.

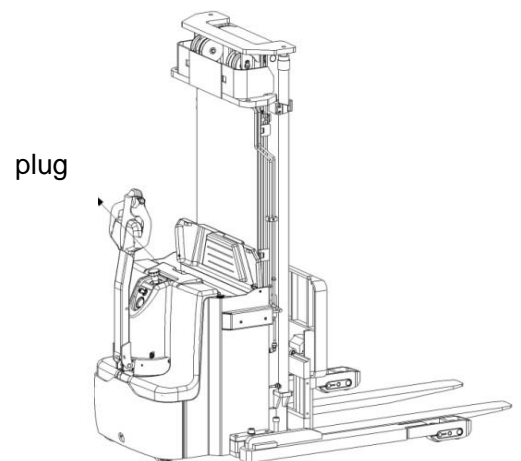

Fig.19: Battery charging

Park the truck at a dedicated secured area with a deidcated power supply.

Lower the forks and remove the load.Open the battery cover and let it stay upright.

Switch the truck off and connect the battery plug to the charging plug of the charger.

The charger starts charging the battery if the charger is connected to the main power supply.

Disconnect the battery plugs after the charger finished charging.

Connect the battery plug with the plug at the truck.

Close the battery cover.

8. REGULAR MAINTENANCE



- Only qualified and trained personnel are allowed to do maintenance on this truck.
- Before maintaining, remove the load and lower the forks to the lowest position.
- If you need to lift the truck, follow chapter 4 b by using designated lashing or jacking equipment. Before working, put safety devices (for instance designated lift jacks,

wedges or wooden blocks) under the truck to protect against accidental lowering, movement or slipping.

- Please pay attention by maintain the tiller arm. The gas pressure spring is pre-loaded by compression. Carelessness can cause injury.
- Use approved and from your dealer released original spare parts.
- Please consider that oil leakage of hydraulic fluid can cause failures and accidents.
- It is allowed to adjust the pressure valve only from trained service technicians.

If you need to change the wheels, please follow the instructions above. The castors must be round and they should have no abnormal abrasion.

Check the items emphasized maintenance checklist.

a. Maintenance checklist

Table 4: Maintenance checklist		Interval (Month)			
		1	3	6	12
	Hydraulic				
1	Check the hydraulic cylinder, piston for damage noise and leakage		•		
2	Check the hydraulic joints and hose for damage and leakage		•		
3	Inspect the hydraulic oil level, refill if necessary		•		
4	Refill the hydraulic oil (12 month or 1500 working hours)				•
5	Check and adjust the function of the pressure valve (2600lbs/3500lbs/4000lbs +0/ +10%)				•
	Mechanical system				
6	Inspect the forks for deformation and cracks		•		
7	Check the chassis for deformation and cracks		•		
8	Check if all screws are fixed		•		
9	Check mast and chain for corrosion, deformation or damages, replace if necessary	•			
10	Check the gearbox for noise and leakage		•		
11	Check the wheels for deformation and damages, replace if necessary		•		
12	Lubricate the steering bearing				•
13	Inspect and lubricate the pivot points		•		
14	Lubricate the grease nipples	•			
15	Replace the guarding and/or protective screen if it is damaged	•			
	Electric system				
16	Inspect the electric wiring for damage		•		
17	Check the electric connections and terminals		•		
18	Test the Emergency switch function		•		
19	Check the electric drive motor for noise and damages		•		
20	Test the display		•		
21	Check if correct fuses are used, if necessary replace.		•		
22	Test the audio warning signal		•		
23	Check the contactors		•		

24	Check the frame leakage (insulation test)		•		
25	Check function and wear of the accelerator		•		
26	Check the electrical system of the drive motor		•		
Braking system					
27	Check brake performance, if necessary replace the brake disc or adjust the air gap		•		
Battery					
28	Check the battery voltage		•		
29	Clean and grease the terminals and check for corrosion and damage		•		
30	Check the battery housing for damages		•		
Charger					
31	Check the main power cable for damages			•	
32	Check the start-up protection during charging			•	
Function					
33	Test the audio warning signal	•			
34	Check the air gap of the electromagnetic brake	•			
35	Test the emergency braking	•			
36	Test the reverse and regenerative braking	•			
37	Test the safety (belly) button function	•			
38	Check the steering function	•			
39	Check the lifting and lowering function	•			
40	Check the tiller arm switch function	•			
41	Test the key switch of damages and function	•			
42	Test the speed limitation switch (lifting height >~12 in)	•			
General					
43	Check if all decals are legible and complete	•			
44	Check if the protective screen and or guarding is not damaged	•			
45	Inspect the castor, adjust the height or replace it, if worn out		•		
46	Carry out a test run	•			

b. Lubricating points

Lubricate the marked points according to the maintenance checklist. The required grease specification is: DIN 51825, standard grease.

- 1 Load roller bearing
- 2 Mast
- 3 Chain
- 4 Hydraulic system
- 5 Steering bearing

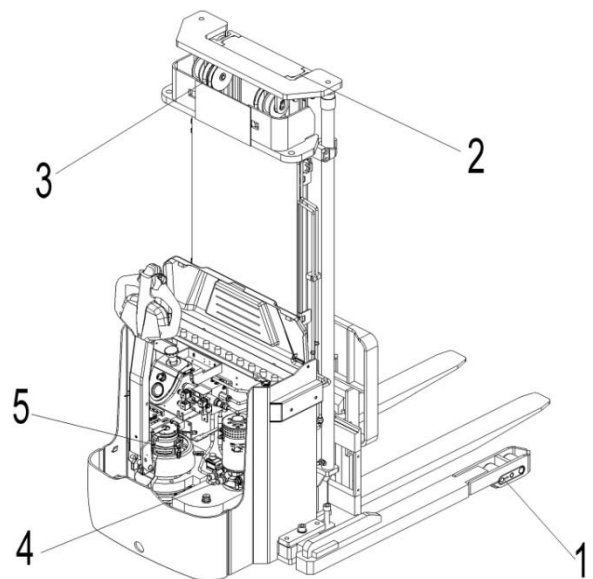

Fig. 20: Lubricating points

c. Check and refill hydraulic oil

It is recommended to use hydraulic oil in connection with average temperature:

Environment temperature	-5°C ~25°C	>25°C
Type	HVLP 32, DIN 51524	HLP 46, DIN 51524
Viscosity	28.8-35.2	41.4 - 47
Amount	9.4L (depends on specific model)	

Waste material like oil, used batteries or other must be probably disposed and recycled according to the national regulations and if necessary brought to a recycling company.

The oil level height shall be in the not lifted position min.9.3L to 9.5L.

If necessary add oil at the filling point.

d. Checking electrical fuses

Remove the main cover. The fuses are located according to fig. 21; the size is according to table 5.

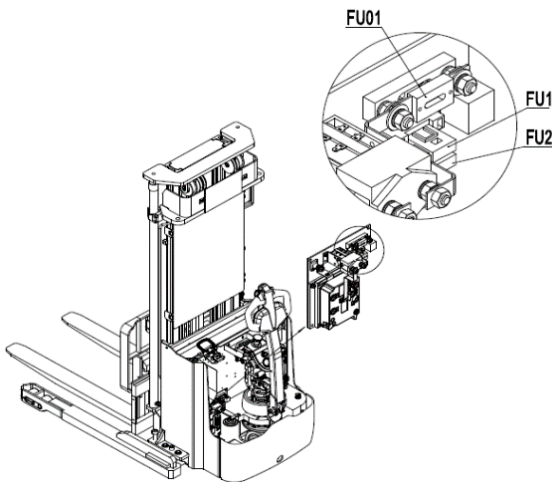

Fig. 21: Location fuses

Table5: Size of the fuses

	Rate
FU1	10A
FU2	10A
FU 01	350A

e. Removing, reattaching guarding



DO NOT USE THIS TRUCK, IF THE GUARDING IS DAMAGED OR NOT CORRECTLY ASSEMBLED!

If the guarding needs to be removed, unbolt the fixing screws and remove the screen carefully. The screws will remain with the screen. For reattaching place the screen to the right position and fix each screw correctly. If you need to replace parts, please call your next service partner.

Move the clips for the protective screen sideways and remove the screen. Assembling is in the opposite direction. Please make sure that the screen is fixed correctly and that the fixing elements are not damaged.

9. TROUBLE SHOOTING



- If the truck has malfunctions follow the instructions, mentioned in chapter 6.

Table 6: Trouble shooting

TROUBLE	CAUSE	REPAIR
Load can't be lifted	Load weight too high	Lift only the max. capacity, mentioned on the ID-plate
	Battery discharged	Charge the battery
	Lifting fuse faulty	Check and eventually replace the lifting fuse
	Hydraulic oil level too low	Check and eventually refill hydraulic oil
	Oil leakage	Repair the hoses and/or the sealing of the cylinder
	Lifting stops at ~71in	Move the protective arms into the downside position
	Lifting stops at ~71in	Check the sensor for the protective arm
	Height sensor for 71in height defect	Check the height sensor on the mast
Oil leakage from air breathing	Excessive quantity of oil.	Reduce oil quantity.
Stacker not starts operating	Battery is charging	Charge the battery completely and then remove the main power plug form the electrical socket.
	Battery not connected	Connect the battery correctly
	The fuse is faulty	Check and eventually replace fuses
	Battery discharged	Charge the battery
	Combined emergency switch is activated	De-activate the combined emergency switch by insert and pull the knob.
	Tiller in the operating zone	Move the tiller firstly to the braking zone.
	Protective arms in the upright position, platform folded upright	Move the protective arms into the downside position
	Foldable platform or protective arms in one of the allowed positions	Check the proximate sensors for the arms and platform
Foldable platform or protective arms not in one of the allowed positions	Check the correct function of the arms and/or platform	
Only travelling in one direction	The accelerator and the connections are damaged.	Check the accelerator and the connections.
The stacker only travels very slowly	The battery is discharged.	Check the battery status at the discharge indicator
	The electromagnetic brake is engaged.	Check the electromagnetic brake
	The relating tiller cables are disconnected or damaged	Check the tiller cables and connections.
	Defective height sensor for reduced speed at ~12in height	Check the sensor

	Electric system overheated	Stop using and cool down the truck
	Defective heat sensor	Check and if necessary replace the heat sensor
The stacker starts up suddenly	The controller is damaged.	Replace the controller.
	The accelerator not moves back to its neutral position.	Repair or replace the accelerator.

If the truck has malfunctions and can't be operated out of the working zone, jack the truck up and go with a load handler under the truck and safe the truck securely. Then move the truck out of the aisle.

10. WIRING/ CIRCUIT DIAGRAM

a. Electrical circuit diagram

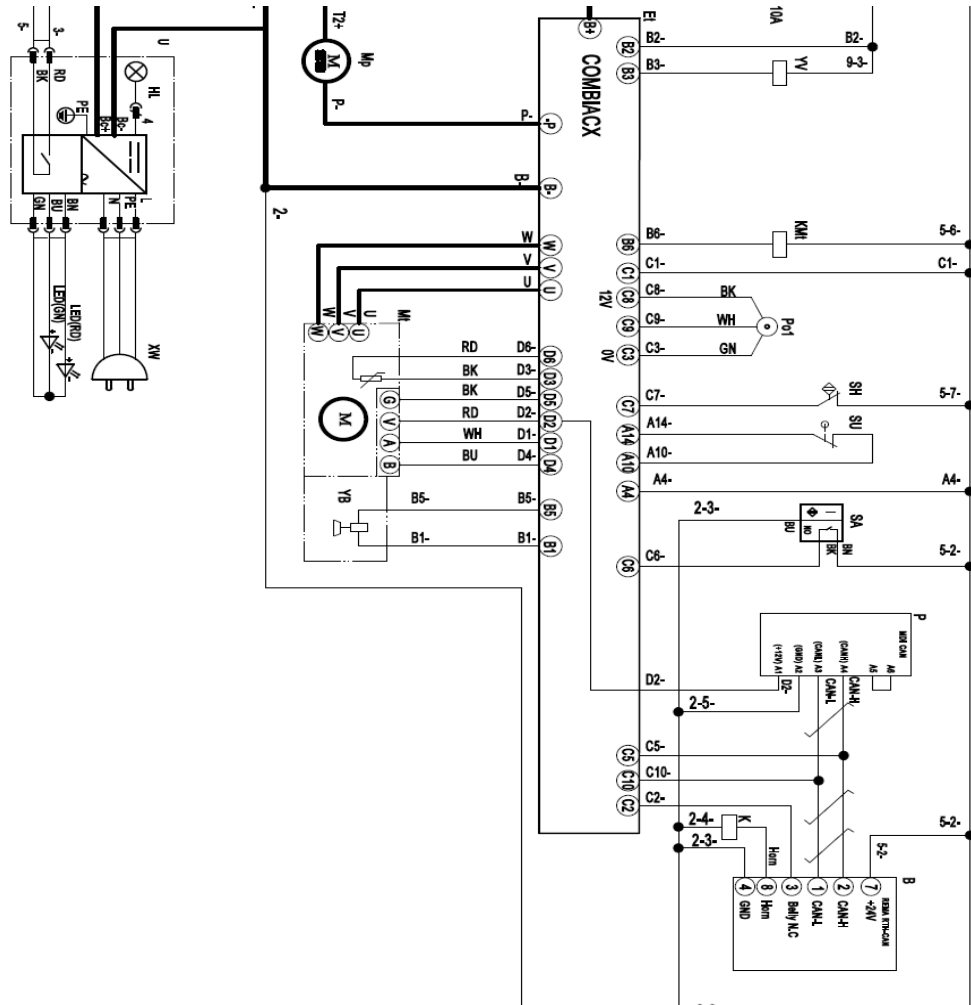

Fig. 22: Electric diagram (without side shift)

Table 7: Description of electrical diagram

Code	Item	Code	Item
GB	Battery	YV	Electromagnetic valve
S	DC power switch	SA	Proximity switch
FU01	Fuse 60A	U	Charger
Mt	Traction motor	XW	Spring cord
Mp	Pump motor	Kr	Temperature protective module
YB	Electromagnetic brake	S1	Micro switch
Et	Traction controller	S2	Micro switch
FU1	Fuse 10A	S3	Micro switch
P	Indicator	S4	Micro switch

LED	LED fault display	BE	Accelerator ET-167E
HA	Horn	K	Relay
VD1	Diode	FU2	Fuse tube 0.5A
KMp	Pump contactor	FU02	Fuse 100A
SU	Micro switch	HL	Charger LED
B	Tiller		

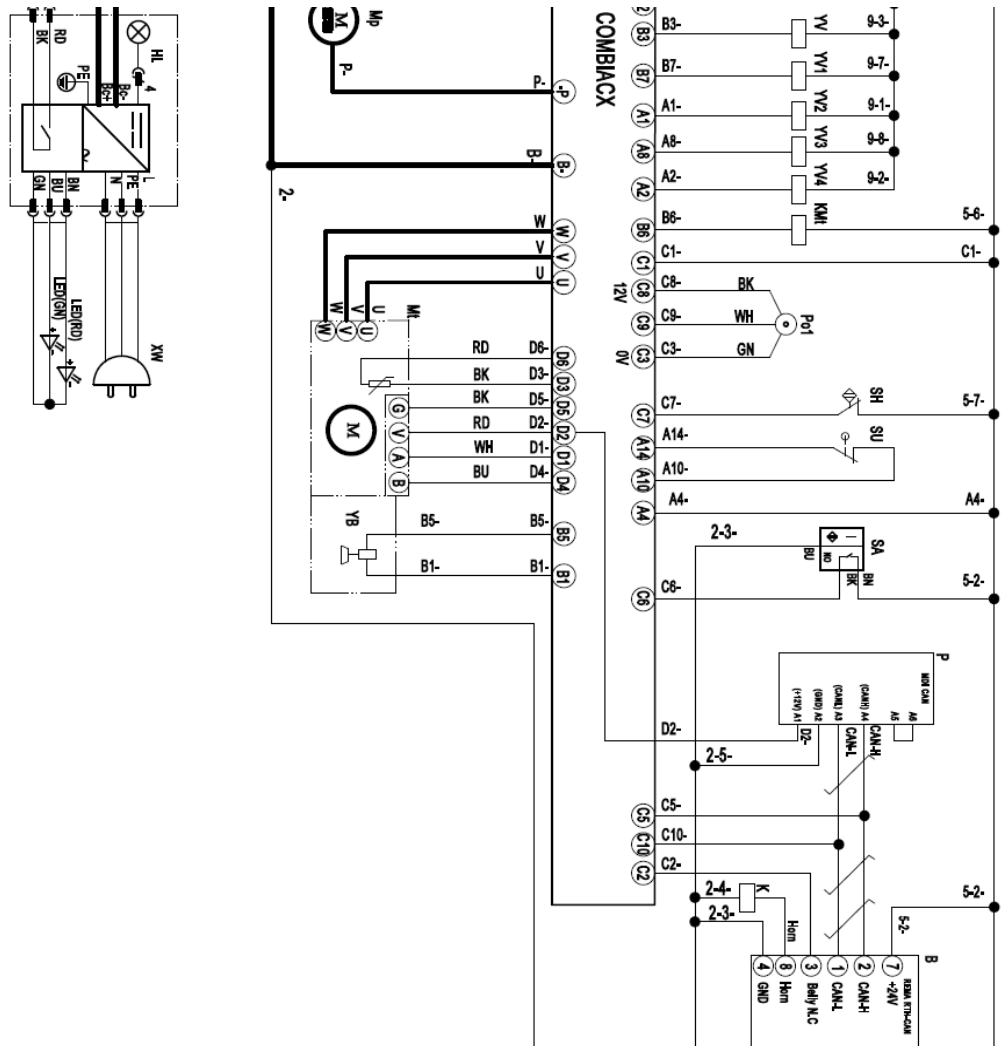

Fig. 23: Electric diagram (with side shift)

Table 8: Description of electrical diagram

Code	Item	Code	Item
B	Tiller	Mp	Pump motor
C	Capacitor	Mt	Traction motor
Et	Traction controller	P	BDI
FU01	Fuse 350A	SH	Magnetic switch
FU1/FU2	Fuse 10A	SA	Proximity switch
GB	Battery	SM	DC power switch
HA	Horn	SU	Micro switch
HS	Proximity switch	SY	Key switch
K	Relay	VD	Diode
KMt	Main contactor	YB	Electromagnetic brake
YV	Electromagnetic valve	YV1/YV2/YV3/YV4	Electromagnetic valve
Po1	Sensor	USB	USB

b. Hydraulic circuit(with side shift)

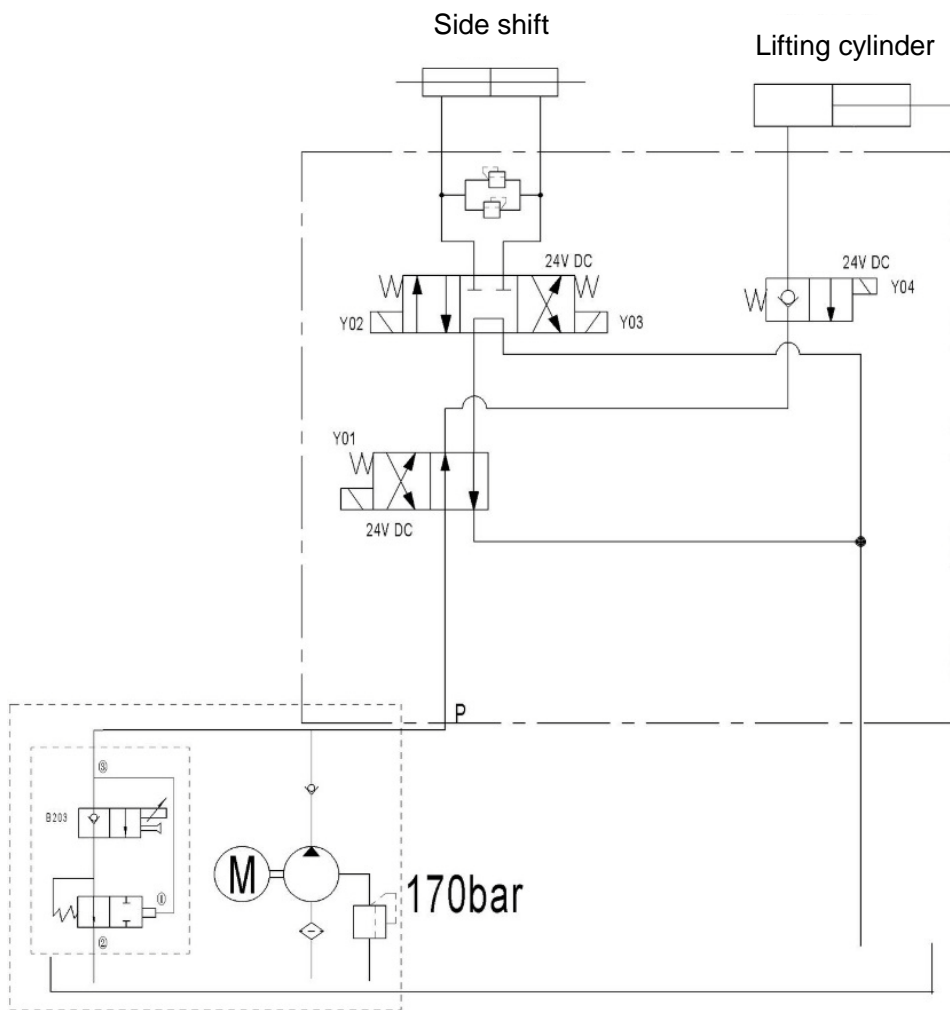

Fig. 24: Hydraulic circuit(with side shift)

c. Hydraulic circuit (without side shift)

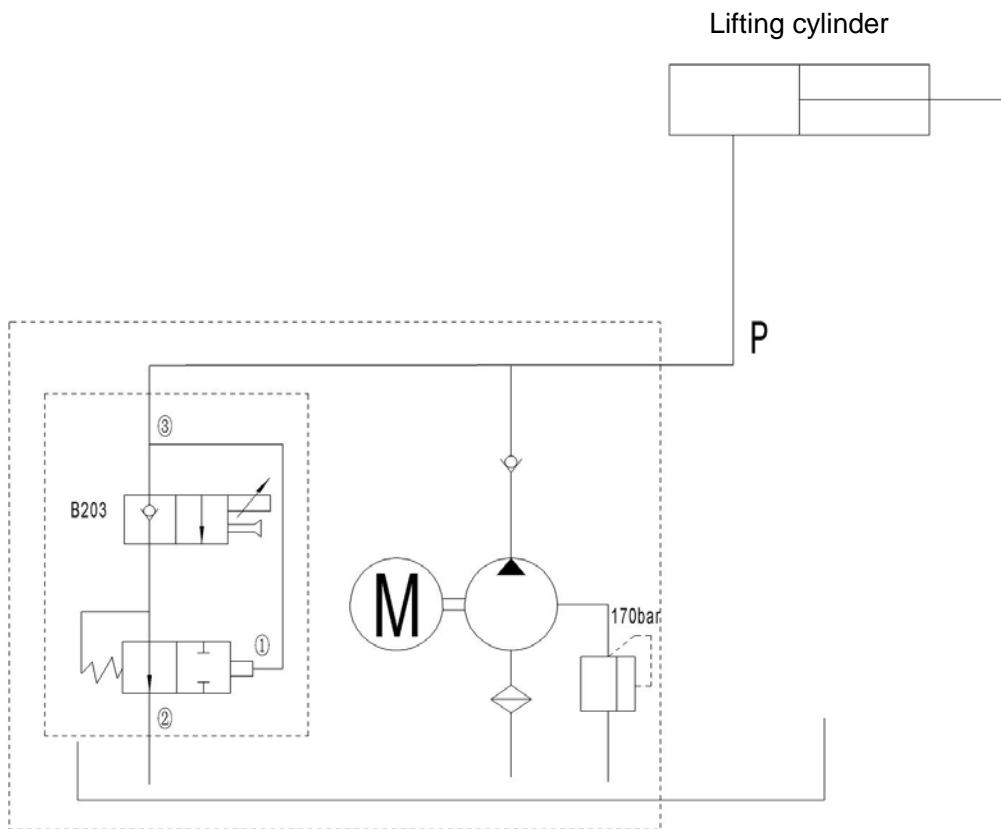

Fig. 25: Hydraulic circuit (without side shift)