

# NOBLELIFT

## INSTRUCTION MANUAL

Battery powered lateral- and front-stacking truck (three sides)

### OPX15

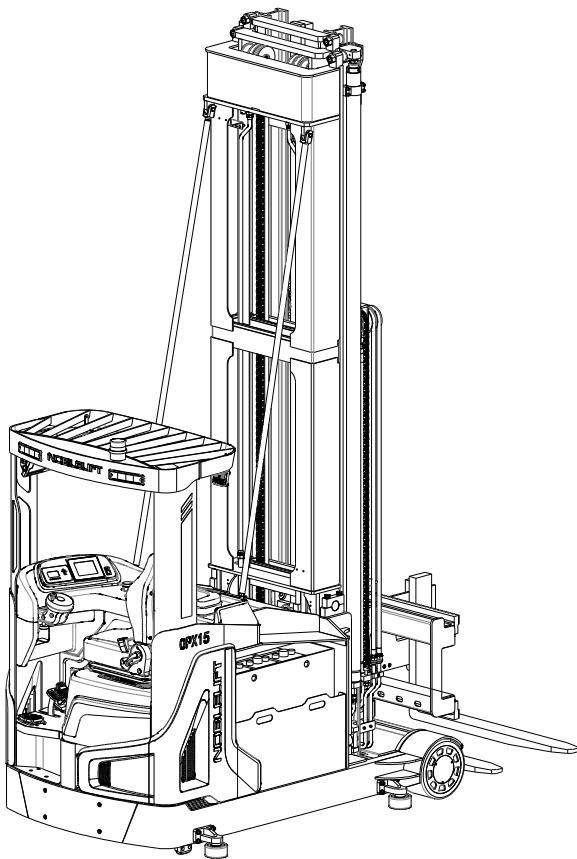

#### **WARNING**

Do not use the truck before reading and understanding these operating instructions of this manual.

#### **NOTE:**

- Please check the designation of your present type at the last page of this manual as well as on the ID-plate.
- Keep it for future reference.

**This truck can only be used in factories, tourist attractions, and amusement parks.**

Version 12/2020

OPX15-SMS-001-EN

## FOREWORD

Before operating the lateral- and front-stacking truck (three sides), read this original instruction manual carefully and understand the usage of the truck completely. Improper operation could cause danger.

This manual describes the usage of different battery powered lateral- and front-stacking truck. When operating and servicing the truck, make sure that it applies to your type.



Keep this manual for future reference. If this or the warning/ caution labels are damaged or lost, please contact your local dealer for replacement.

This truck complies with the requirements according to EN 3691-1 (Industrial trucks- safety requirements and verification, part 1), EN 12895 (Industrial trucks- electromagnetic compatibility), EN 12053 (Safety of industrial trucks- test methods for measuring noise emissions), EN 1175-1 (Industrial truck safety – electrical requirements), assumed the truck is used according to the described purpose.

The sound pressure level at driver's seat for this machine is 70 dB(A) according to EN 12053.

### ATTENTION:

- Environmentally hazardous waste, such as batteries, oil and electronics, if handled incorrectly, will cause negative effect to the environment or human health.
- The waste packages should be sorted and put into solid dustbins according to the materials and be collected disposal by local special environment protection bureau. To avoid pollution, it's forbidden to throw away the wastes randomly.
- To avoid leaking during the use of the products, the user should prepare some absorbable materials (scraps of wooden or dry duster cloth) to absorb the leaking oil in time. To avoid second pollution to the environment, the used absorbable materials should be handed in to special departments in terms of local authorities.
- Our products are subject to ongoing developments. Because this manual is only for the purpose of operating/ servicing the reach truck, therefore please have understanding, that there is no guarantee out of particular features out of this manual.



**NOTE: The left sign in this manual indicates warning and caution, which may lead to death or serious injury if instructions are not followed.**

### Copyright

The copyright remains with the company, mentioned on the CE- certificate at the end of this document or, if sold within USA, with the company, mentioned on the company sticker.

# Table of Contents

1. CORRECT APPLICATION .....	4
2. DESCRIPTION OF THE TRUCK .....	5
a. Overview of the main components .....	5
b. Main technical data .....	7
c. Description of the safety devices and warning labels (Europe and other, excepting USA) .....	10
d. Identification plate (ID-plate) .....	11
3. WARNINGS, RESIDUAL RISK AND SAFETY INSTRUCTIONS .....	11
4. COMMISSIONING, TRANSPORTING, DECOMMISSIONING .....	12
a. Commissioning.....	12
b. Loading and unloading/ transportation .....	13
c. Storage.....	14
5. REGULAR INSPECTION .....	14
6. OPERATIONAL INSTRUCTIONS .....	15
a. Operational control devices .....	15
b. Power-on the truck.....	16
c. Travelling.....	16
d. Steering .....	17
e. Braking .....	17
f. Residual lift diagram .....	17
g. Lifting.....	18
h. Lowering.....	18
i. Fork lateral movement (left/right).....	18
j. Fork rotation (left/right).....	19
k. Fork rotation and lateral movement (left/right).....	19
l. Malfunctions .....	19
m. Emergency .....	19
7. BATTERY CHANGES AND REPLACEMENT.....	20
a. Replacement.....	21
b. Battery indicator and alarm .....	22
c. Charging.....	22
8. REGULAR MAINTENANCE .....	23
a. Maintenance checklist.....	23
b. Lubricating points.....	25
c. Check and refill hydraulic oil .....	26
d. Checking electrical fuses .....	26
9. TROUBLE SHOOTING .....	27
10. WIRING/CIRCUIT DIAGRAM.....	28
11. HYDRAULIC DIAGRAM.....	30
12. DIAGNOSTICS AND TROUBLESHOOTING.....	31

13. Declaration of Conformity (valid for sale in the EU) ..... 50  
[GB] CE Declaration of Conformity ..... 50

# 1. CORRECT APPLICATION

To ensure the safety of personal and equipment, drivers shall observe the following precautions:

1. Only drivers who have been trained and hold a industrial trucks driving license can drive this truck;
2. This truck is suitable for hard and flat indoors floor conditions;
3. Check the control and alarm devices before driving this truck. If any damage or defect is found, it shall be operated after repair;
4. During handling, the load shall not exceed the specified value. Fork should go under the goods and load should be evenly placed on the fork. Unbalanced loading is prohibited and picking up objects with single fork is not allowed;
5. Start, steer, drive, brake and stop slowly and smoothly. Slow down when steering on wet or smooth floors;
6. When driving this truck with goods, lower the goods as low as possible and the goods should be moved laterally to the middle position. It is very dangerous to drive the truck with fork tip or the goods beyond the side of the chassis;
7. Be careful when driving on the slope: move forward uphill, move backward downhill, avoid steering uphill or downhill;
8. When driving this reach truck, pay attention to pedestrians, obstacles and potholes, and pay attention to the clearance above the reach truck;
9. It is not allowed to stand on fork or truck;
10. It is not allowed to stand under or walk under the elevated part of the truck;
11. Only operate the truck from the driver's position;
12. Do not handle unsecured or loosely packed goods, and carefully handle goods in large size;
13. When driving in the racks, drive slowly, move straightly in and straightly out, when the fork or goods are not completely removed from the racks, do not steer in case of collision.
14. When rotate the fork, it is necessary to observe the safe distance between the goods/ fork and surrounding objects to avoid collision;
15. Immediately stop using when the failure occurs, and the label shall be clearly indicated;
16. Lower the fork to the ground when leaving the truck, park the truck on level ground, turn off the power and remove the key.

It is only allowed to use this electric reach truck according to this instruction manual.

The capacity is marked on capacity sticker as well on the identification plate. The operator has to pay attention to the warnings and safety instructions.

Operating lighting must be minimum 50 Lux.

## Modification

No modifications or alterations to this truck which may affect, for example, capacity, stability or safety requirements of the truck, shall be made without the prior written approval of the original truck manufacturer, its authorized representative, or a successor thereof. This includes changes affecting, for example braking, steering, visibility and the addition of removable attachments. When the manufacturer or its successor approve a modification or alteration, they shall also make and approve appropriate changes to capacity plate, decals, tags and operation and maintenance manual.

Only in the event that the truck manufacturer is no longer in business and there is no successor in the interest to the business, may the user arrange for a modification or alteration to a powered industrial truck, provided, however, that the user:

- a) arranges for the modification or alteration to be designed, tested and implemented by an engineer(s) expert in industrial trucks and their safety,
- b) maintains a permanent record of the design, test(s) and implementation of the modification or alteration,
- c) approves and makes appropriate changes to the capacity plate(s), decals, tags and instruction handbook, and
- d) affixes a permanent and readily visible label to the truck stating the manner in which the truck has been modified or altered, together with the date of the modification or alteration and the name and address of the organization that accomplished those tasks.

By not observing these instructions, the warranty becomes void.

## 2. DESCRIPTION OF THE TRUCK

### a. Overview of the main components

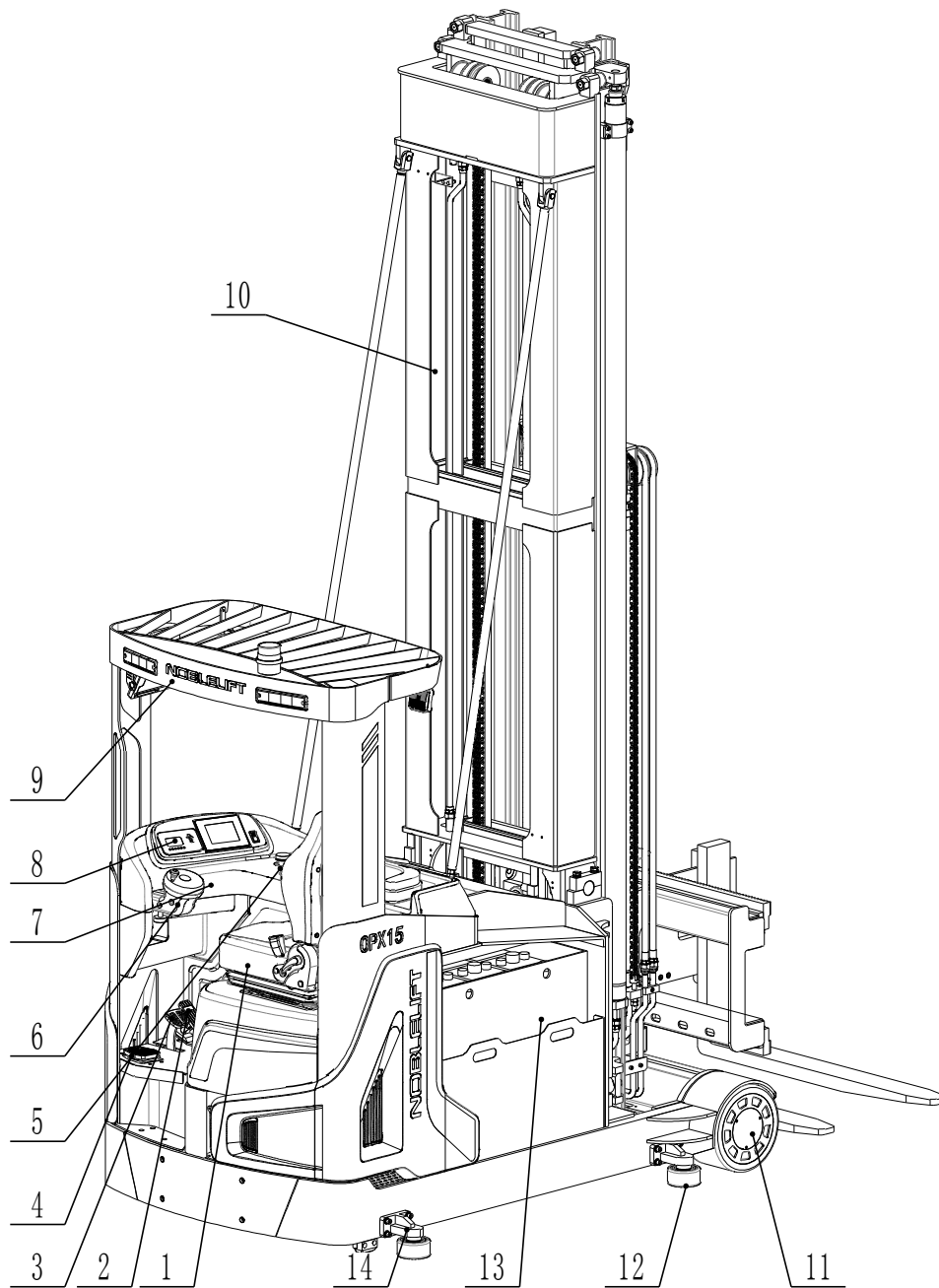
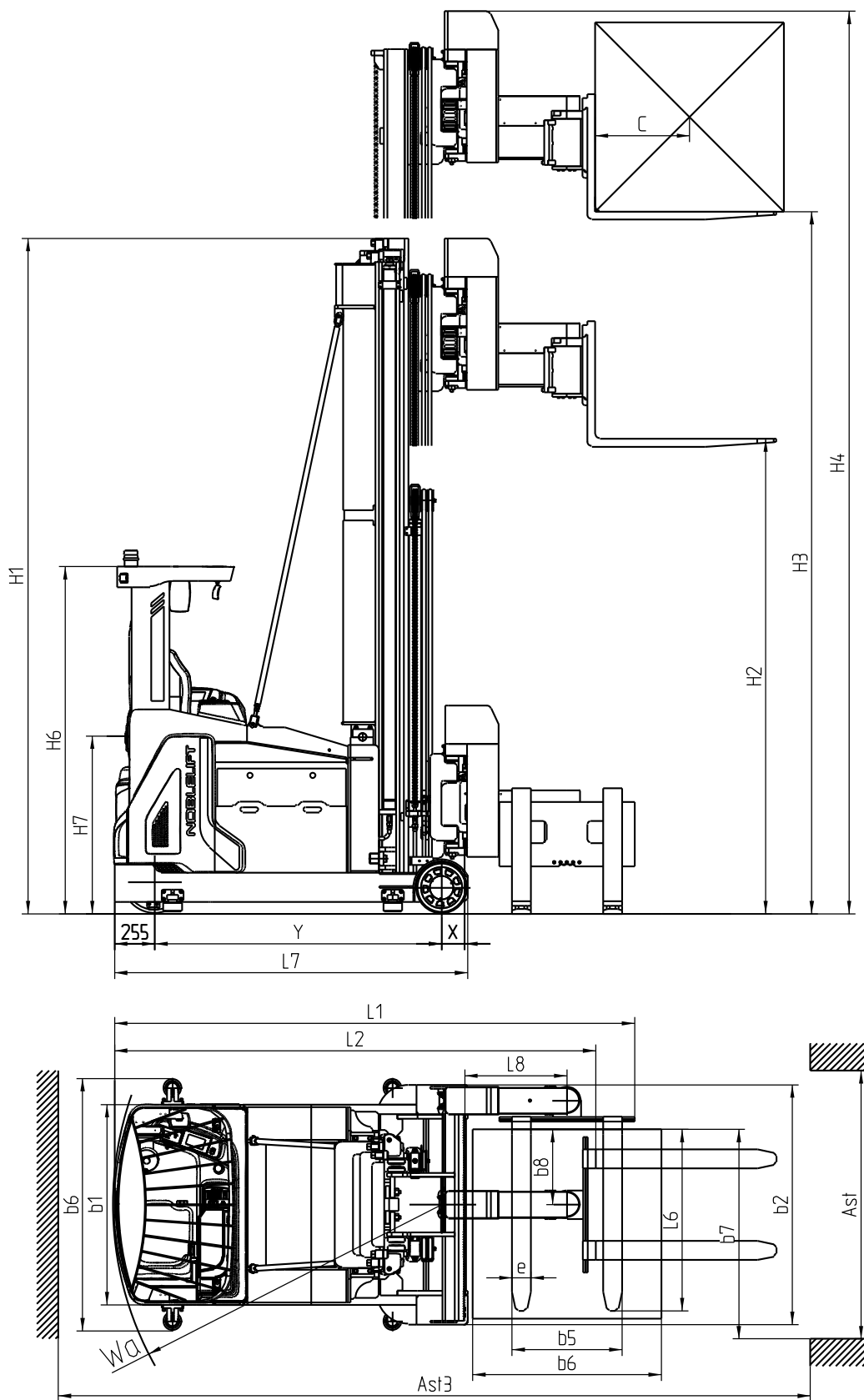

Fig. 1: Overview of main components

- |                         |                   |
|-------------------------|-------------------|
| 1. Seat assembly        | 8. Display        |
| 2. Accelerator pedal    | 9. Overhead guard |
| 3. Brake pedal          | 10. Mast          |
| 4. Safety pedal switch  | 11. Load wheel    |
| 5. Central control unit | 12. Guide roll    |
| 6. Steering wheel       | 13. Battery       |
| 7. Key switch           | 14. Guide roll    |

**b. Main technical data**



**Fig 2: Structure schematic drawing**

Table 1: Main technical data for standard version

Type sheet for industrial truck acc. to VDI 2198				
Distinguishing mark	1.1	Manufacturer (abbreviation)	NOBLELIFT	
	1.2	Manufacturer's type designation	OPX15	
	1.3	Drive: electric (battery type, mains, ...), diesel, petrol, fuel gas	Battery type	
	1.4	Operator type: hand, pedestrian, standing, seated, order-picker	Seated	
	1.5	Rated capacity/ rated load	Q (t)	1.5
	1.6	Load centre distance	c (mm)	600
	1.8	Load distance, centre of drive axle to fork	x (mm)	146
	1.9	Wheelbase	y (mm)	1820
	1.10	Counter drive wheel/ Counter weight	z (mm)	255
	Weight	2.1	Service weight (with battery)	kg
Chassis	3.1	Tires		Polyurethane (PU)
	3.2	Tire size, front (load wheel)	ØxW (mm)	400x152
	3.3	Tire size, rear (drive wheel)	ØxW (mm)	330x178
	3.5	Wheels, number front/ rear(x=driven wheels)		2/1x
	3.7	Tread, rear	b <sub>11</sub> (mm)	1342
Dimensions	4.2	Height, mast lowered	h <sub>1</sub> (mm)	3280/3610/3950/4280/4610
	4.3	Free lift	h <sub>2</sub> (mm)	2260/2590/2920/3250/3580
	4.4	Lift	h <sub>3</sub> (mm)	6500/7500/8500/9500/10500
	4.5	Height, mast extended	h <sub>4</sub> (mm)	7860/8860/9860/10860/11190
	4.7	Height of overhead guard (cabin)	h <sub>6</sub> (mm)	2200
	4.8	Seat height relating to SIP/ stand height	h <sub>7</sub> (mm)	1120
	4.19	Overall length	l <sub>1</sub> (mm)	3306
	4.20	Length to face of fork	l <sub>2</sub> (mm)	3060
	4.21	Overall width	b <sub>1</sub> (mm)	1270/1520
	4.22	Fork dimensions DIN ISO 2331	s/ e/ l (mm)	50/125/1150
	4.23	Fork carriage ISO 2328, class/ type A, B		2/A
	4.24	Fork-carriage width	b <sub>3</sub> (mm)	860
	4.25	Fork spread	b <sub>5</sub> (mm)	260/ 830
	4.27	Width across guide rolls	b <sub>6</sub> (mm)	1600
	4.29	Reach, lateral	b <sub>7</sub> (mm)	1320
	4.31	Ground clearance, laden, below mast	m <sub>1</sub> (mm)	75
	4.32	Ground clearance, centre of wheelbase	m <sub>2</sub> (mm)	75
4.33	Aisle width for pallets 1000x1200 crossways	A <sub>st</sub> (mm)	1700	



	4.34	Aisle width for pallets 800×1200 lengthways	$A_{st}$ (mm)	1700
	4.35	Turning radius	$W_a$ (mm)	2100
	4.42	Pallet width	$b_{12}$ (mm)	1200
	4.43	Pallet length	$l_6$ (mm)	800/1200
<b>Performance</b>	5.1	Travel speed, laden/ unladen	km/h	8/8.5
	5.2	Lift speed, laden/ unladen	m/s	0.2/0.3
	5.3	Lowering speed, laden/ unladen	m/s	0.4/0.4
	5.4	Reaching speed, laden/ unladen	m/s	0.15/0.15
	5.8	Max. gradeability, laden/ unladen	%	5
	5.10	Service brake		Regenerative braking/hydraulic braking
	5.11	Parking brake		Electromagnetic Braking
<b>Electric-engine</b>	6.1	Drive motor rating S2 60min	kW	7
	6.2	Lift motor rating at S3 15%	kW	12.5
	6.3	Battery acc. to DIN 43531/35/36 A, B, C, no		A, 9PZS900
	6.4	Battery voltage/ nominal capacity $K_5$	(V)/(Ah)	48/900
	6.5	Battery weight	kg	1550
<b>Addition data</b>	8.1	Type of drive unit		Three-phase AC
	8.2	Operating pressure	bar	150
	8.3	Oil volume	l /min	40
	8.4	Sound pressure level at driver's seat	dB (A)	<70
	8.6	Steering design		Electronic steering
<b>Note</b>				

**Table of working device parameters of OPX15**

Designation	Lift $h_3$ mm	Free lift $h_2$ mm	Height, mast lowered $h_1$ mm	Height, mast extended $h_4$ mm	Weight kg
Three stage mast FFL (Full Free Lift)	5500	1930	2950	6860	2220
	6500	2260	3280	7860	2340
	7500	2590	3610	8860	2460
	8500	2920	3950	9860	2580
	9500	3250	4280	10860	2700
	10500	3580	4610	11190	2820

Note

## C. Description of the safety devices and warning labels (Europe and other, excepting USA)

Warning labels:

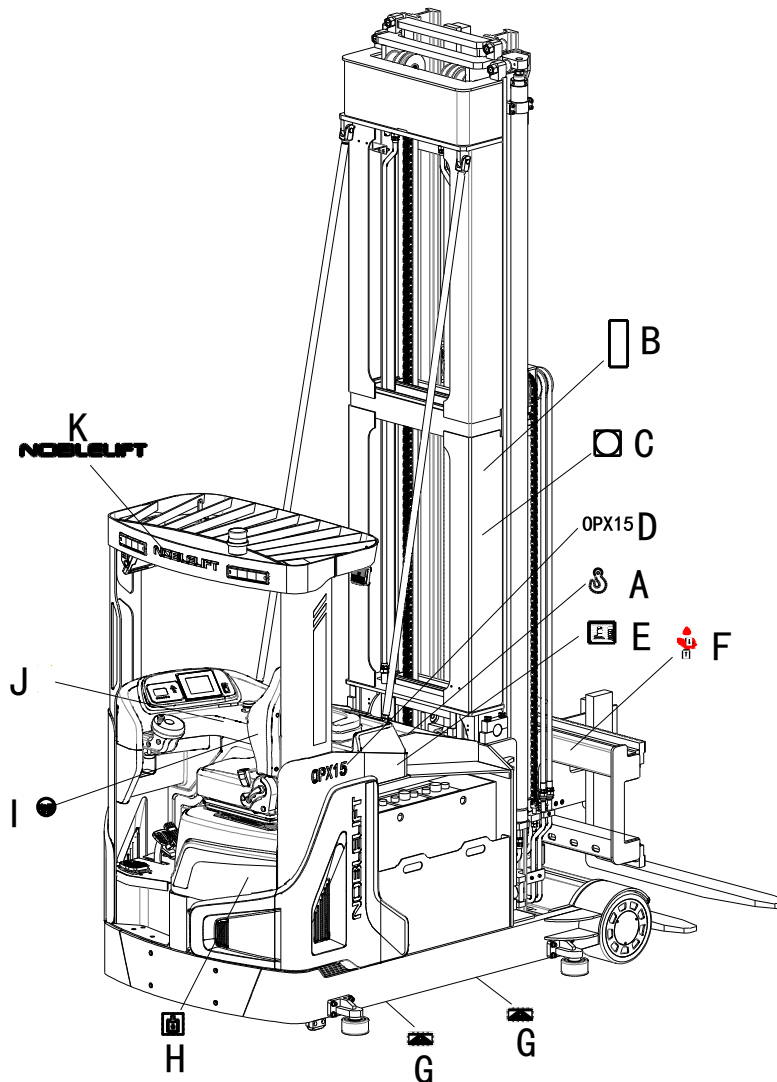
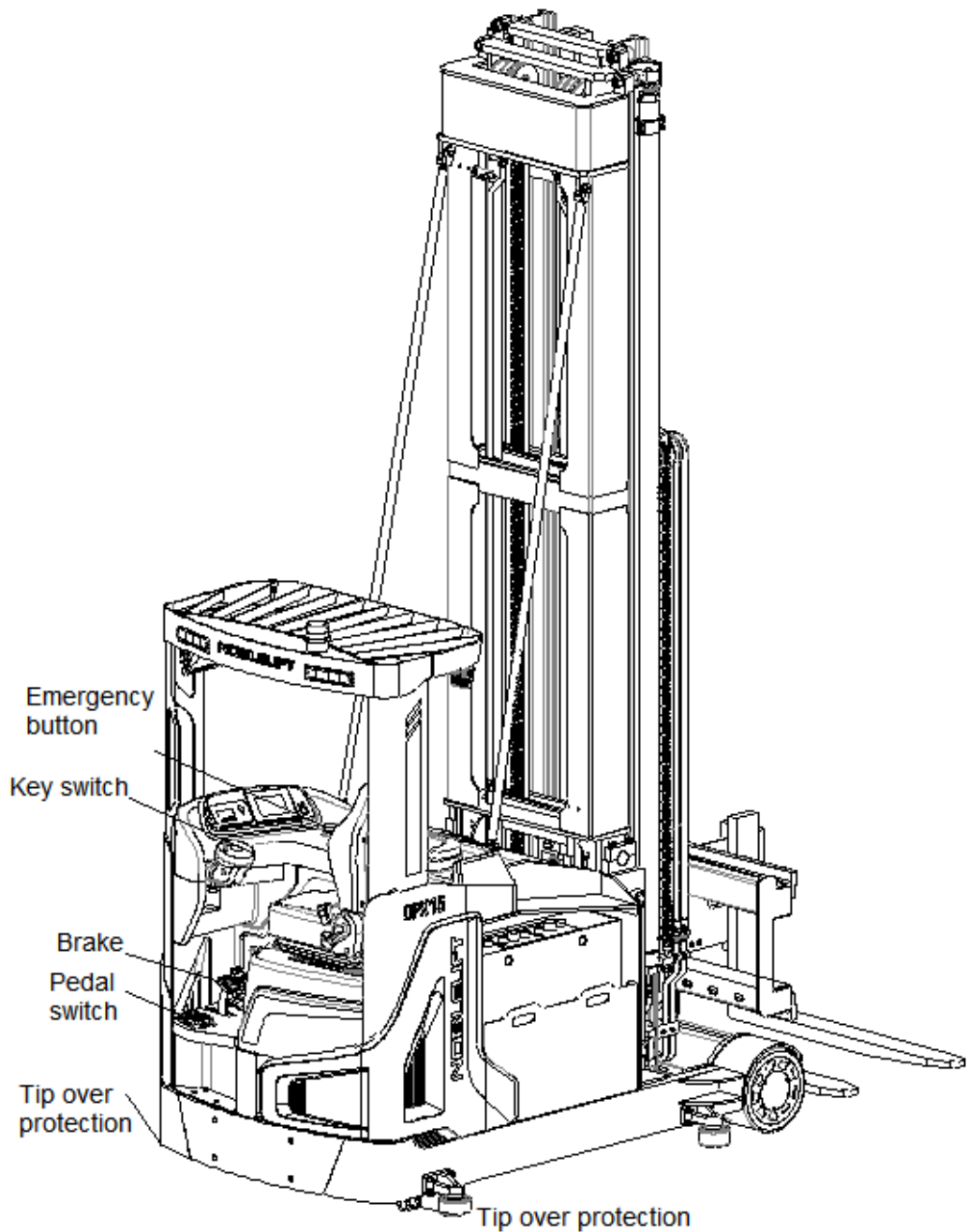

Fig 3: Warning labels

- A. Crane hook label: The place for allowed crane.
- B. Warning label: Do not stand under or on the fork, otherwise it may cause injury.
- C. Warning label: Do not stand inside mast or reach your hand inside, otherwise it may cause injury.
- D. Model sticker: Indicate the type of the truck.
- E. Identification plate (ID-plate): Indicate the basic information of truck, such as specification, production date, product number, etc.
- F. Hand pinching warning label: There is a risk of hand injury at this position.
- G. Fork loading label: The fork insertion position during loading.
- H. Oil filling sticker: Hydraulic oil should be filled at this position.
- I. Seat belt sticker: Seat belt should be fastened when driving.
- J. Reading warning label: Read and follow service manual.
- K. Logo sticker

**Safety devices:**



**Fig 4:** Safety devices

**Emergency button:** Please press this button immediately to cut of the power supply when the truck is out of control, all lifting-, lowering-functions will be stopped.

**Key switch:** To prevent against unauthorized access, turn the key counterclockwise and pull it out.

**Brake:** To stop the truck when it is driving.

**Tip over protection:** To reduce the risk of side tip over of the truck. It's forbidden to remove the protection.

**Pedal switch:** Operate the truck with left foot on the foot pedal switch, otherwise it will be failed.

Attention: Emergency button, drive key switch, brake, rollover protection, pedal switch and hydraulic circuit explosion-proof valve are safety devices of the truck. Safety devices and labels above must be kept in good condition, please replace in time in case of damage or absence.

## d. Identification plate (ID-plate)

<b>Battery powered lateral- and front-stacking truck (three sides)</b> Special Equipment Manufacturing License No. : TS2510350-2021 Tel: 4008-836115			
Type	xxxx	Rated Capacity	xxx kg
Nominal Voltage	xx V	Service Weight (w.o. battery)	xxxx kg
Max Battery Weight	xxx kg	Min Battery Weight	xxx kg
Net Weight (w.o. load )	xxx kg	Max Lift Height	xxx mm
Serial Number		Manufacturing Date	
Equipment Code		Manufacturer Art. No.	
<b>This truck is only used in factories, tourist attractions and tourist sites.</b> Manufacturer: Noblelift Intelligent Equipment Co., LTD No.528, Changzhou Road, Taihu Street, Changxing County, Zhejiang Province			

Fig 5: Identification plate

## 3. WARNINGS, RESIDUAL RISK AND SAFETY INSTRUCTIONS



- Do not use truck in environments with explosive gas, explosive dust or acid and alkali corrosion;
- Do not use truck in the environment with poor outdoor or ground conditions;
- Do not put feet or hands under or inside the lifting mechanism;
- Do not stand in front or behind the truck while driving or lifting/lowering;
- Do not overload, the load weight and lifting height must meet load curve requirements;
- Do not put foot outside the truck when driving which may cause injuries;
- Do not lift people may which may cause people falling down and severe injury suffering;
- Do not push or pull goods;
- Do not drive the truck on slopes;
- Do not use truck with unstable, loose or unbalanced load, gravity center must be between two fork legs;
- To prevent against unauthorized access, park the truck, turn off the power and pull out the key;
- Do not make any truck modification without written consent from manufacturer;
- Do not lift the cargo in the case of wind. Lifting will be unstable under the wind influence.

Watch difference in floor levels when driving. Load could fall down or the truck could get uncontrollable.

Keep watching the condition of load. Stop operating the truck if load becomes unstable.

Brake the truck and activate the emergency button by pushing when sliding load on or off the truck. If the truck has any malfunctions, follow chapter 8.



- The truck is intended to be used on hard and flat ground indoors whose roughness should be within 1cm/m<sup>2</sup>;
- The operator should hold driving license and have been trained;
- When operating the truck, the operator has to wear safety shoes.
- The truck is intended to be used with ambient temperatures between +5°C~+40°C;
- The operating lighting must be minimum 50 Lux.

## 4. COMMISSIONING, TRANSPORTING, DECOMMISSIONING

### a. Commissioning

After receiving our new reach truck or for re-commissioning you have to do following before (firstly) operating the truck:

- Check if all parts are included and not damaged
- Mast installation (please follow the instructions to install mast);
- Do the work according to the daily inspections as well as functional checks.
- Check battery installation and charge instructions (follow chapter 7).

#### **Mast assembling:**

Mast assembling required equipment:

#### **Lifting equipment:**

Driving ( 5 tons maximum load ) or fork lifting ( 3 tons load capacity and 4.5 m lifting height)

**Assistant tools:** Wrench S19, S24, S32, S41 and crowbar.

Safety precautions:

Assembling operators must take appropriate training or be trained by professional personnel on-site to guide the assembling operation.

Operators for lifting equipment must get appropriate operating qualifications.

If the truck is directly forked on the crossbeam of the mast, the mast and the fork carriage must be tied together with the protection rope to avoid the risk of slipping.

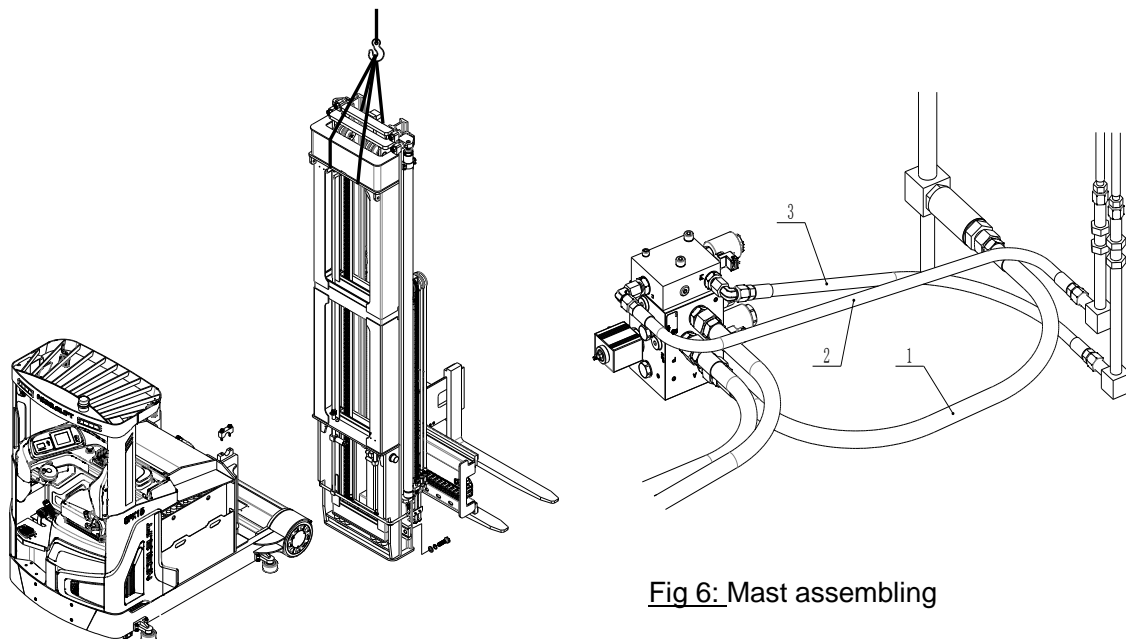

**Fig 6: Mast assembling**

**Table 2:** Weight of truck chassis and mast

Truck Model	OPX15					
Truck chassis pack weight [kg]	3600					
Truck chassis pack size [mm]	2260x1520X2200					
Lift height H3 [mm]	5500	6500	7500	8500	9500	10500
Mast pack weight [kg]	2220	2340	2460	2580	2700	2820
Mast pack size [mm]	3100x1500 X1850	3400x1500 X1850	3700x1500 X1850	4000x1500 X1850	4300x1500 X1850	4630x1500 X1850

## b. Loading and unloading/ transportation

When load and unload the truck, refer to the guide diagram below. The weight for chassis and mast is shown in table 2, for the whole truck weight, please check the ID plate.

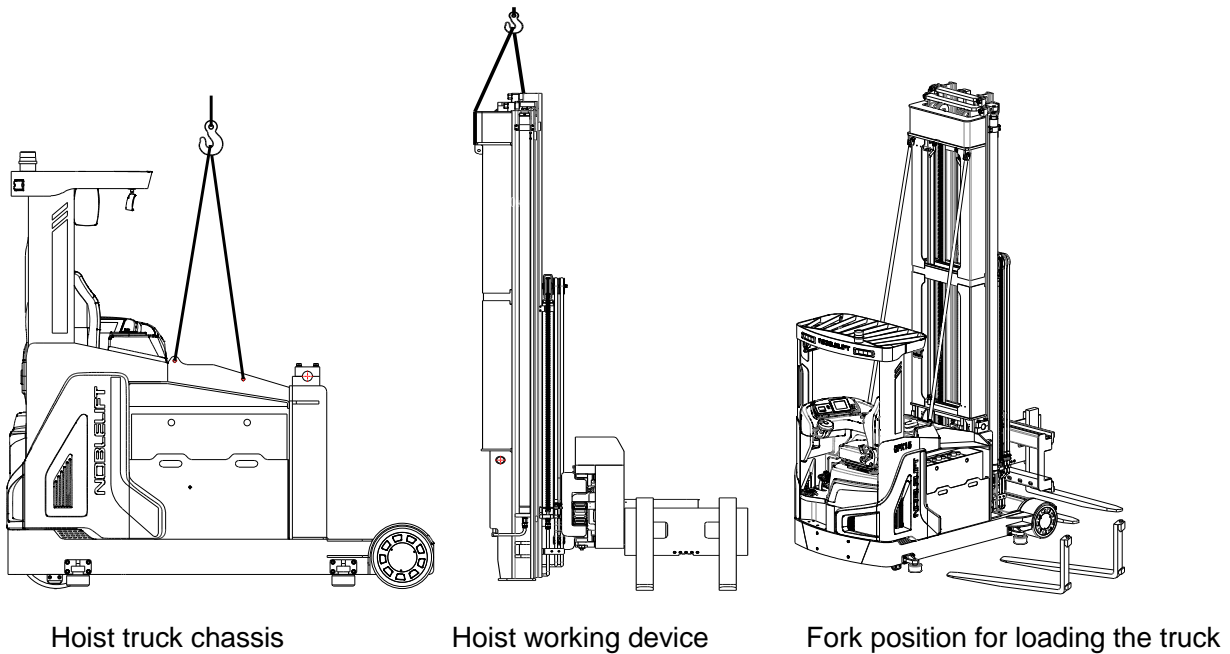

**Fig 7:** Hoisting

### Loading and unloading



USE DEDICATED CRANE AND LIFTING EQUIPMENT.  
DO NOT STAND UNDER THE SWAYING LOAD.  
DO NOT WALK INTO THE HAZARDOUS AREA DURING LIFTING.  
PLACE THE TRUCK ON A LEVEL GROUND.

### Transportation



DURING TRANSPORTATION ON A LORRY OR TRUCK, ALWAYS FASTEN THIS STACKING TRUCK SECURELY.

Lower the fork and park the truck securely.

Fasten the truck according to Fig. 8, put the wood blocks under the driving cab to prevent damage to the drive wheel during transporting.

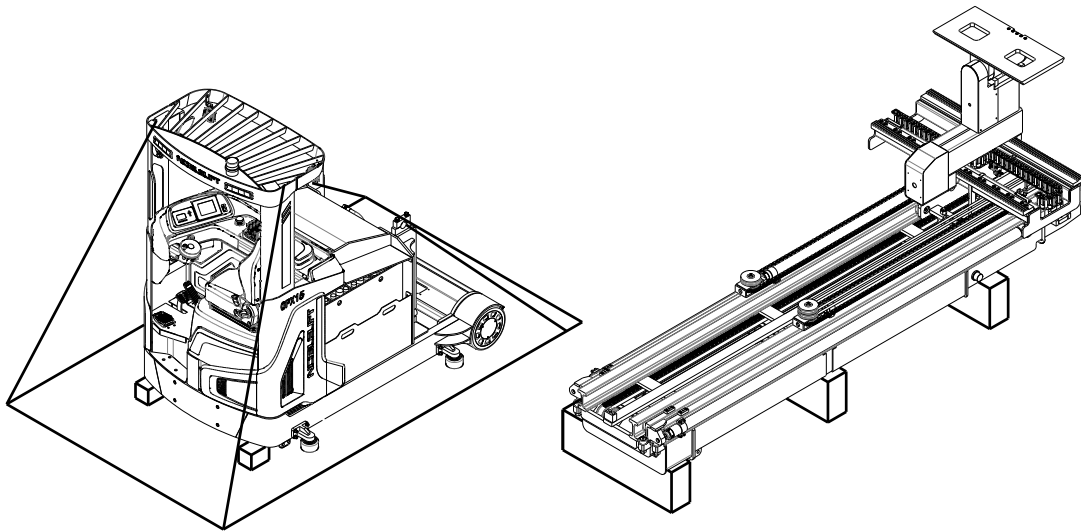

Fig 8: Fixing points for transportation

### **C. Storage**

Lower the fork to the lowest position, as shown in figure 8, padded the cabin with sleepers to lift the drive wheel to prevent damage due to long-term storage.

Apply grease to all lubrication points mentioned in this manual (regular inspection) to prevent rust and dust accumulation on the truck.

Charge trucks that have been out of service for a long time once a month to prevent damage to battery. For trucks that are eventually scrapped and out of service, please hand them to the relevant recycling company. According to regulations, oil, batteries and electronic components are recycled or treated in a harmless manner.

## **5. REGULAR INSPECTION**

This chapter describes pre-shift checks before putting the truck into operation.

Regular inspection is effective to find the malfunction or fault on this truck. Check the truck on the following points before operation.



**REMOVE LOAD FROM TRUCK AND LOWER THE FORK.  
DO NOT USE THE TRUCK IF ANY MALFUNCTION IS FOUND.**

- Check for scratches, deformation or cracks.
- Check if there is any oil leakage from the cylinder.
- Check the function of driving in both directions
- Check the chain and rollers are without damage or corrosion.
- Check the smooth movement of the wheels.
- Check the function of the emergency brake by activating the emergency button.

- Check the functions of foot brake.
- Check the lifting and lowering functions.
- Check the seat is assembled tightly.
- Check the function of horn.
- Check if all bolts and nuts are tightened firmly.
- Check the function of key switch.
- Check the function of speed limitation.
- Visual check if there are any broken electric wires.
- If supplied with a backrest extension, check it for damages and correct assembling.

## 6. OPERATIONAL INSTRUCTIONS

### a. Operational control devices

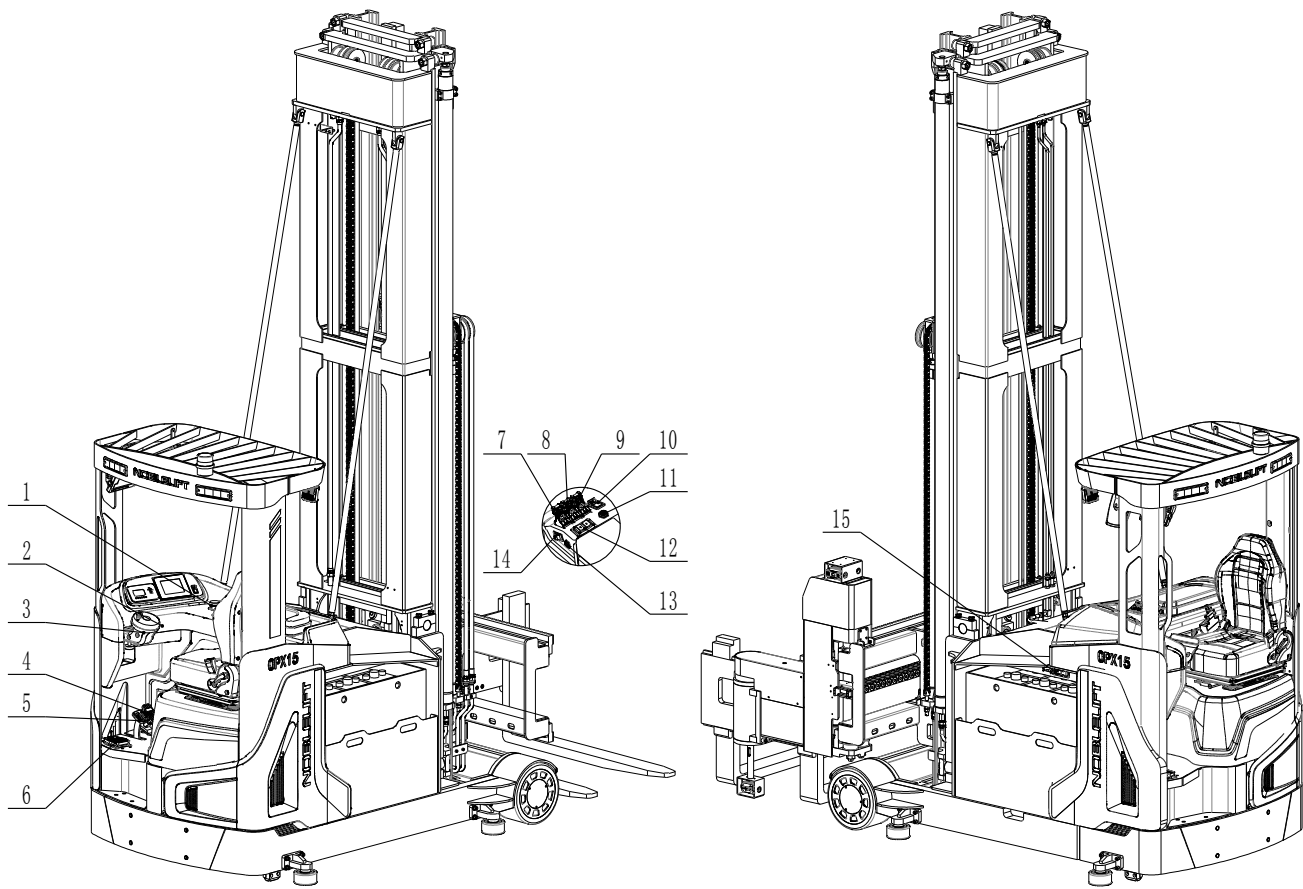

Fig. 9: Operational control devices

No.	Device	Function
1	Emergency switch	This switch is the main power switch, which should be pressed immediately in case of emergency to cut off the power supply of the whole truck.
2	Key switch	This switch is used to turn on or off the power supply of the control circuit, and it should be turned off and the key should be removed when you do not operate the truck or leave the truck.
3	Steering wheel	It is used to control the travel direction of the truck.



4	Accelerator	It is used to control the start/ acceleration/ deceleration/ stop of the truck.
5	Foot brake pedal	It is used to control the service brake of the truck.
6	Safety pedal switch	It is a safety switch, the left foot should always be placed on this switch when operating the truck.
7	Lifting and lowering control stick	It is used to control the lifting and lowering of the fork, pull the control stick to lift the fork, and push the control stick to lower the fork.
8	Left and right lateral movement control stick	It is used to control the left and right lateral movement of the fork. Pull the control stick, the fork moves to the right. Push the control stick, the fork moves to the left.
9	Left and right rotation control stick	It is used to control the left and right rotation of the fork. Pull the control stick, the fork rotates to the right. Push the control stick, the fork rotates to the left.
10	Turn signal lamp switch	It is used to control the turn signal lamp on and off.
11	Parking brake switch	Press this switch to activate the parking brake of the truck.
12	Driving direction switch	It is used to control the truck's front and rear travel direction.
13	Horn button	It is used to control the horn.
14	Left and right joint operation control stick	Control the fork rotation and movement from the left middle position to the right middle position or from the right middle position to the left middle position.
15	Battery connector	It is a connector between battery and truck. Connect this part with the charger to charge the battery.

## **b. Power-on the truck**

Before operating this truck, please make sure that the load or other equipment will not cause insufficient visibility, and ensure that the load is level and placed stably.

Pull the emergency button (1), insert the key switch (2), and turn the key clockwise to "ON" position, then stop on the safety pedal switch (6). Before starting the truck, please activate the horn button (13) by pressing it to warn others if necessary. Then the truck is power on.

Note: please set the driving direction switch in the neutral position before power-on the truck, otherwise the operation sequence fault will be activated.

## **c. Travelling**

After starting the truck by turning the inserted key to "ON" position, firstly press the safety pedal switch (6), then put your hand on the operating area. Move the switch to the forward or backward direction, and adjust the travelling speed by controlling the accelerator pedal (4) carefully until it reaches your desired speed. The speed will be slower if you release the accelerator pedal, control the speed to ensure safety. If you need abrupt deceleration, please step on the brake pedal (5).

Carefully drive the truck to the destination. Observe the route conditions and adjust the travelling speed by operating the accelerator pedal.

This truck is equipped with adequate safety equipment to avoid accidents. When the height of the fork is higher than the free lifting height, the speed of the truck will be reduced for smooth travelling and safe work. When the fork lowers below the free lifting height, the lower the fork height, the slower the truck.

Please keep the lifting height of the fork below 0.5m when you need to travel over a longer distance.

Please drive the truck to the safe storage area and lower the fork to the lowest position after every use. Turn the key counterclockwise to "OFF" position and remove the key.

Attention: Turn on the power, the system will start self-inspection. When there is something wrong with the electrical system, such as open circuit, short circuit, or active button, if you stamp the pedal switch, speed control device is not in the neutral position, and the truck cannot be operated and a fault code appears, only when the fault from electrical system is solved, the truck can be operated normally.

## **d. Steering**

The truck equips with an electric steering system. Take care by operating a truck with this kind of system. Steer the truck by turning the steering wheel clockwise and counterclockwise.

Turn the steering wheel to make the drive wheel move straightly forward, truck will reach full speed. Turn the steering wheel a certain angle to turn the drive wheel to achieve steering. During steering, when the turning angle is larger than  $\pm 10^\circ$ , comparing with straight driving, the steering speed is different, the larger the turning angle, the slower the speed, which ensures the smooth steering and safe operation.

## **e. Braking**

The braking performance depends on the track conditions and the load conditions of the truck.

- When driving the truck, if the right foot releases the accelerator pedal, the truck begins to decelerate. If you need a shorter braking distance, please directly step on the brake pedal until the truck stops;
- Release the safety pedal switch (6), the braking is activated and the truck will be stopped.
- Press the emergency button (1), the braking function is activated and the truck will be stopped..

Attention: if there is load on the fork, the brake should be activated slowly. Do not use emergency braking, otherwise the load may drop from the fork.

## **f. Residual lift diagram**

The residual lift diagram indicates the maximum capacity  $Q$  [kg] for a given load centre  $c$  [mm] and the corresponding lift height  $h_3$  [mm] for the truck with horizontal load.

The white mark on the mast indicates the possible lifting limits.

For instance, OPX with a load centre of gravity distance ( $c$ ) of 600mm and a maximum lift height ( $h_3$ ) of 9500mm, the maximum capacity ( $Q$ ) is 800 kg.

Model	OPX15		
Mast	9500		

h <sub>3</sub> (mm)	Q (kg)		
9500	800	600	400
9000	900	700	500
8500	1000	800	600
8000	1100	900	700
7500	1200	1000	800
7000	1300	1100	900
6500	1500	1300	1100
C(mm)	600	700	800

Fig. 10: Residual lift diagram

### g. Lifting



DO NOT OVERLOAD THE TRUCK! THE MAXIMUM CAPACITY IS 1500KG REFERRING TO THE IDENTIFICATION PLATE.

LIFT THE LOAD THAT IS INDICATED AND ALLOWED IN RESIDUAL LIFT DIAGRAM ONLY, OTHERWISE IT MAY DAMAGE THE TRUCK.

Pull the lifting and lowering control stick (7) backwards to lift the fork until it reaches your desired lifting height.

When the lifting height of the unladen truck is above 3m or the lifting height of the laden truck is above 1m, please reduce the speed of the truck. Be careful of operation during steering, no sharp start, stop or steering.

Be cautious during lifting operation in racks, pay attention to the distance between the load and the rack.

### h. Lowering

If the fork is in the racking, firstly travel out of the racking carefully with or without the pallet.

Push the lifting and lowering control stick (7) forwards for lowering.

Lower the load until the fork is clear of the pallet, then move the truck carefully out of the load.

### i. Fork lateral movement (left/right)

Push the control stick (8) forwards, the fork moves to the left.

Pull the control stick (8) backwards, the fork moves to the right.

## **j. Fork rotation (left/right)**

Push the left and right rotation control stick (9) forwards, the fork rotates to the left.  
Pull the left and right rotation control stick (9) backwards, the fork rotates to the right.

## **k. Fork rotation and lateral movement (left/right)**

Push the left and right joint operation control stick (14) forwards, the fork rotates to the left, and the lateral movement frame moves to the right.

Pull the left and right joint operation control stick (14) backwards, the fork rotates to the right, and the lateral movement frame moves to the left.

## **l. Malfunctions**

If there are any malfunctions or the truck is inoperative, please stop using the truck and activate the emergency button (1) by pressing it. If possible, park the truck in a safe area, turn the key switch (2) counterclockwise and remove the key. Immediately inform the manager or call your service. If necessary, remove the truck out of the operating area by using dedicated towing/ lifting equipment.

When the truck breaks down, stop using it immediately and put a label for indication;

When the truck breaks down, the wrench indicator at the bottom of the display will be on. CURTIS hand-held unit can help to find out the fault cause.

## **m. Emergency**

In emergencies, press the emergency button (1) immediately in case of loss of control and other emergencies. All electrical functions will stop.

If the truck fails to lower the lifted fork, please use a 6mm Allen-wrench to unscrew the screw (emergency descent) shown in the figure below to lower the fork.

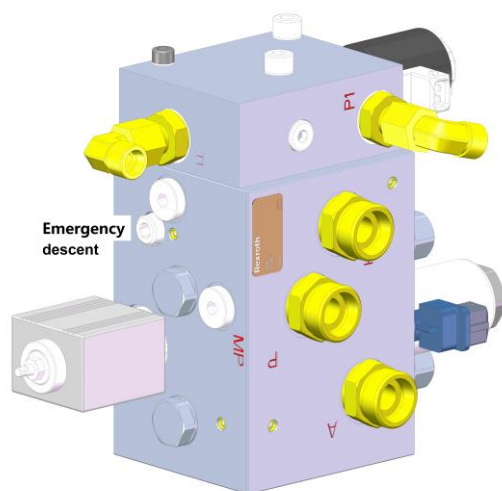

## 7. BATTERY CHANGES AND REPLACEMENT



- Only qualified personnel are allowed to service or charge the batteries. The instructions of this manual and battery manufacturer's manual must be observed.
- The batteries are lead acid batteries.
- Recycling of batteries must comply with national regulations.
- When disposing of the batteries, it is not allowed to use an open flame, which may cause a gas explosion.
- In the area of battery charging neither burning materials nor burning liquids are allowed. Smoking is prohibited and the charging area must be ventilated.
- Park the truck securely before starting charging or installing/replacing the batteries.
- Before finishing the maintenance work, make sure, that all cables are connected correctly and that there are no disturbing towards other components of the truck.
- In the process of charging or operating, due to water evaporation, check the electrolyte weekly, distilled water should be added to the battery regularly, the electrolyte level must be maintained between the MAX. and the MIN. level. Start charging after filling distilled water.

Distilled water supplement and filling quantity are indicated as below:

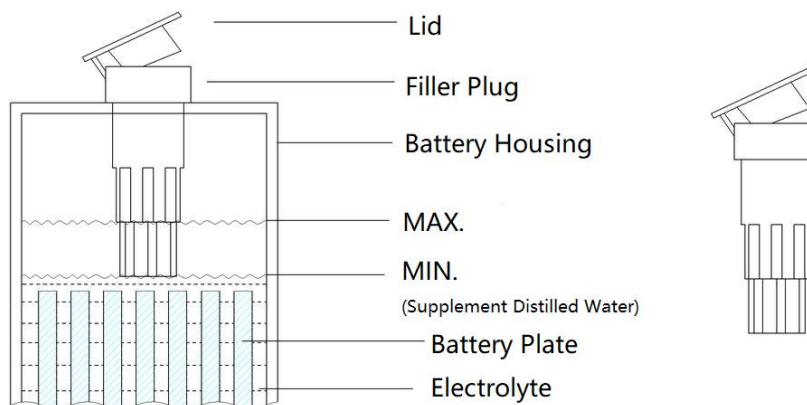

Fig. 11: Electrolyte level



Note: When the electrolyte level is found insufficient, do not replenish the acid (check the specific gravity after fully charged). The battery replenisher must be distilled water!  
**After charging, the standard specific gravity of the electrolyte is 1.28g/ml.**

The truck is equipped with the following lead-acid battery:  
48V 9PzS 900AH (standard configuration) [1074x820x650 mm (LxWxH)]



IT IS ONLY ALLOWED TO USE THE LEAD-ACID BATTERIES.  
THE WEIGHT OF BATTERY HAS AN INFLUENCE TO THE TRUCK'S STABILITY.  
PLEASE CONSIDER THE MAXIMUM AND MINIMUM WEIGHT OF THE BATTERY,  
WHICH SHOULD MATCH WITH THE REQUIRED BATTERY WEIGHT ON ID PLATE.

## a. Replacement

Park the truck safely, follow the steps described below to pull out the battery, turn off the key switch (2), press the emergency button (1), disconnect the battery connector (15), and lift the battery directly. Be aware that battery may tip over if the equipment is unsafe. Installation is in reverse order of removal.

Please follow the steps below:

Step 1: Move the truck to the battery carrier and align with each other.

Step 2: Remove the battery side panel and battery baffle.

Step 3: Press the wire release button of the electric winch, pull out the wire rope and make it go around the pulley on the battery holder, and hang it on the battery box as shown in Fig b.

Step 4: Press the wire retract button of the electric winch, the battery will be pulled out.

If you need to move the battery to the battery compartment of the truck as shown in Fig d, hang the wire rope directly on the battery, press the retract button of the electric winch.

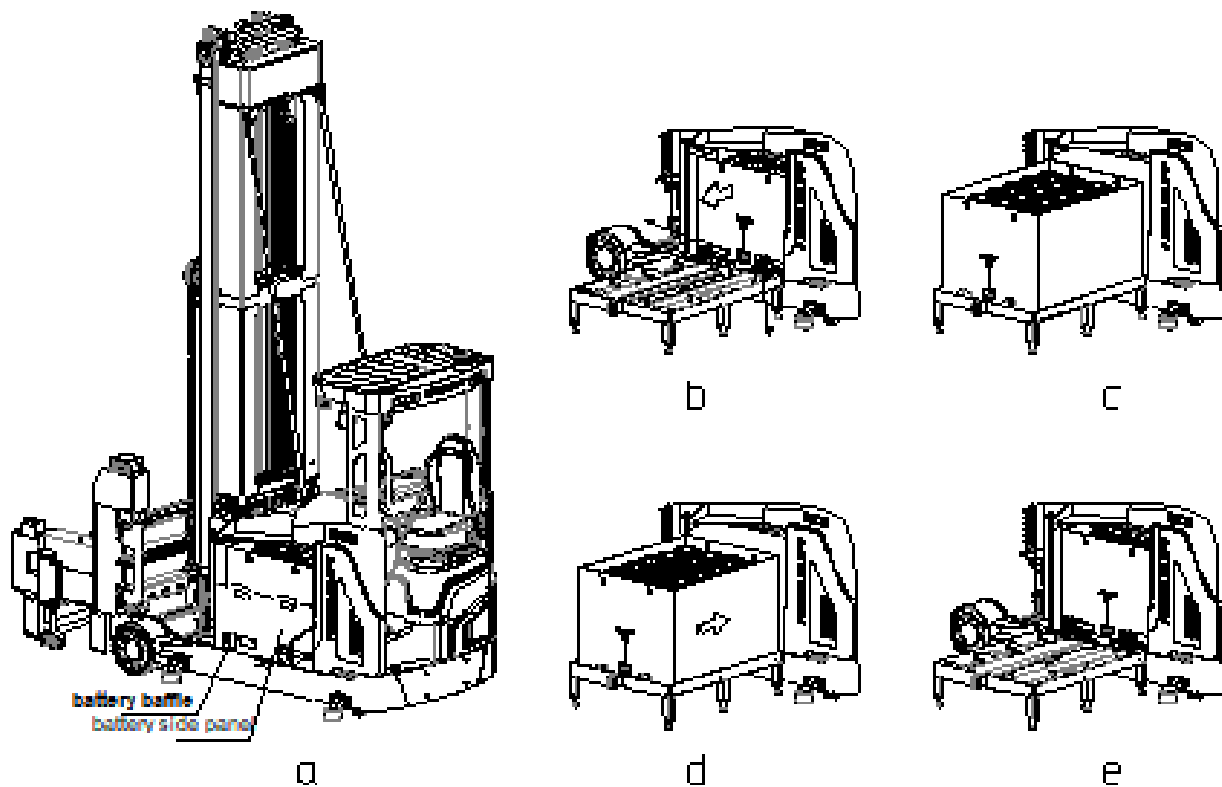

Fig. 12: Battery extraction

## b. Battery indicator and alarm

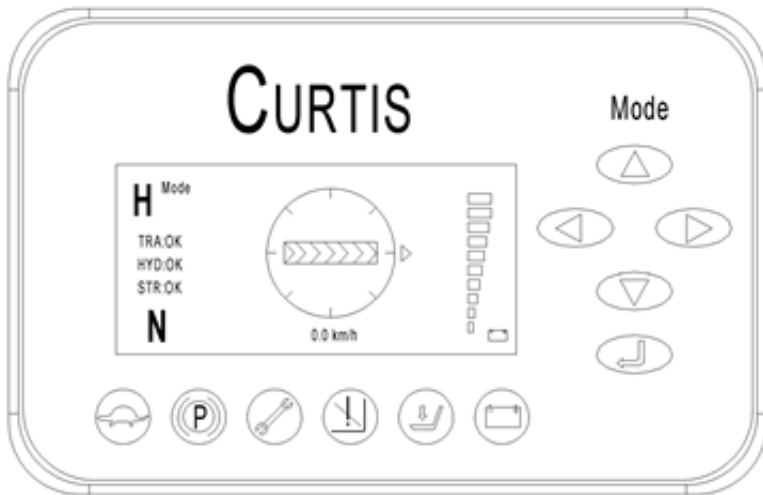

Fig. 13: Display

State of charge (SOC) of the battery is displayed on the right side of the indicator, if the battery is fully charged, the indicator displays 100% (10 segments), when SOC of battery is 20%, the battery symbol will light on (the sixth one from left in figure 11), indicating the battery needs charging. When SOC of the battery is 10%, the prohibition symbol will light on (the fourth one from left in figure 11), the lifting function is not available but slow travelling is available.

When the battery is removed, the indicator will display TRA: 5.7, the travelling is not available but mast movement (extended/ retracted) is available, and the maximum lifting height is about 600mm.

There is a “Mode” button on the right side of the indicator, you can switch the drive mode by operating “Mode” button, shown as upper left corner in Fig 13:

H	Mode	high speed mode	top speed drive 10Km/h
S	Mode	normal mode	top speed drive 8.4Km/h
E	Mode	economic mode	top speed drive 6.3Km/h

When switch to economic mode, slow speed (turtle) symbol is on (the first indicator from left in Fig 13).

## c. Charging



- Before charging ensure that an appropriate charger is used for charging.
- Please fully understand the instructions of the charger manual before using.
- Please follow these instructions.
- The room for charging must be ventilated.

Park the truck at a specific secured area with a dedicated power supply. Lower fork and remove load. Turn the truck off and connect the battery connector with the charger.

The charger starts charging the battery.

Disconnect the battery connector and the charger when charging is completed.

Connect the battery connector (15) to the truck.

## 8. REGULAR MAINTENANCE



- Only qualified and trained personnel are allowed to do maintenance to this truck.
- Remove load from fork and lower fork to the lowest position before maintenance.
- If you need to lift the truck, follow chapter 4b by using designated lashing or jacking equipment. Before working, put safety devices (for instance designated lift jacks, wedges or wooden blocks) under the truck to protect against accidental lowering, movement or slipping.
- If you need to remove the high-pressure oil hose, lower the fork and turn off the power. After 10 minutes, release the pressure in each hose and remove the hose.
- Use approved and from your dealer released original spare parts.
- Please consider that oil leakage of hydraulic fluid can cause failures and accidents.
- It is allowed to adjust the pressure valve only from trained service technicians.

If you need to replace the wheels, please follow the instructions above. The casters must be round and free of abnormal wear.

Check the key items listed on the maintenance list.

### a. Maintenance checklist

		Interval (Month)			
		1	3	6	12
<b>Hydraulic system</b>					
1	Check the hydraulic cylinder(s), piston for damage noise and leakage		•		
2	Check the hydraulic joints for damage and leakage		•		
3	Inspect the hydraulic oil level, refill if necessary		•		
4	Refill the hydraulic oil ( 12 month or 1500 working hours )				•
<b>Mechanical system</b>					
5	Inspect the fork for deformation and cracks		•		
6	Check the chassis for deformation and cracks		•		
7	Check if all screws are fixed		•		
8	Check mast and chain for deformation and damages, replace if necessary	•			
9	Check the gearbox for abnormal sound, noise and leakage		•		
10	Check the wheels for deformation and damages, replace if necessary		•		
11	Check and lubricate the mast and chain	•			
12	Check and fill the brake fluid if necessary	•			
13	Lubricate the grease nipples		•		
14	Check the function of brake	•			
<b>Electrical system</b>					
15	Inspect the electric wiring for damage		•		
16	Check the electric connections and terminals		•		
17	Test the Emergency switch function		•		
18	Check the electric drive motor for noise and damages		•		



19	Test the display		•		
20	Check, if correct fuses are used		•		
21	Test the warning signal		•		
22	Check the contactor (s)		•		
23	Check the frame leakage (insulation test)		•		
24	Check function and mechanical wear of the accelerator		•		
25	Check the electrical system of the drive motor		•		
<b>Braking system</b>					
26	Check brake performance, if necessary replace disc or adjust air gap		•		
<b>Battery</b>					
27	Check the battery electrolytic liquid proportion		•		
28	Clean the terminals and check for corrosion and damage		•		
29	Check the battery housing for damages		•		
<b>Charger</b>					
30	Check the main power cable for damages			•	
31	Check the start-up protection during charging			•	
<b>Function</b>					
32	Check the horn function	•			
33	Check the air gap of the electromagnetic brake	•			
34	Test the emergency braking	•			
35	Test the reverse and regenerative braking	•			
36	Check the steering function	•			
37	Check the lifting and lowering function	•			
38	Check the tiller arm switch function	•			
39	Check the key switch for damage or normal work	•			
40	Check the speed limitation switch function	•			
<b>General</b>					
41	Check if all decals are legible and complete	•			
42	Check if the protective screen and or guarding is not damaged	•			
43	Inspect the castors, adjust the height or replace these if worn out.		•		
44	Carry out a test run	•			

## b. Lubricating points

Lubricate the marked points according to the maintenance checklist. The required grease specification is: DIN 51825, standard grease.

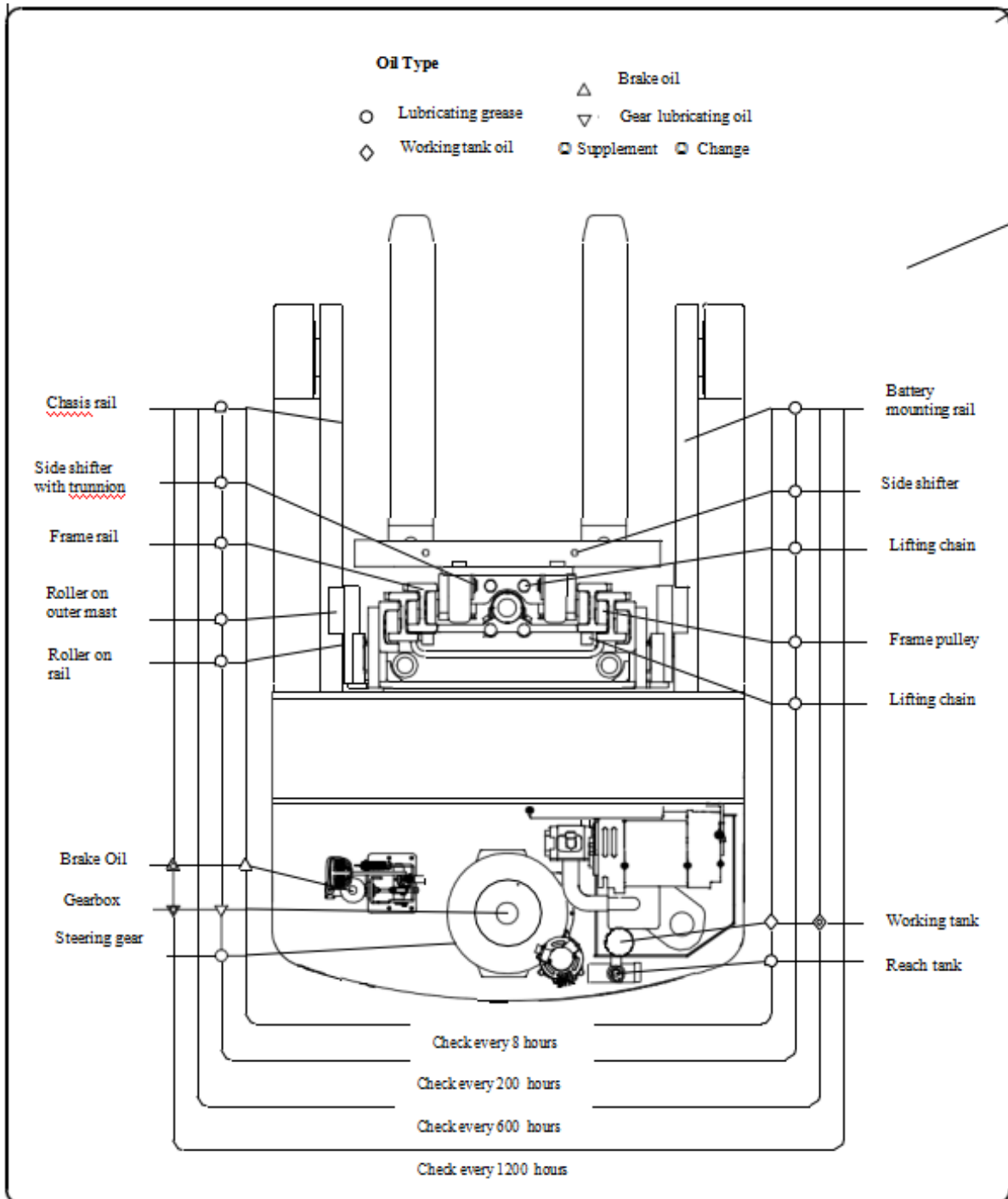

Fig 14: Lubricating points

### **c. Check and refill hydraulic oil**

It is recommended to use the hydraulic oil:

- Type: H-LP 46, DIN 51524
- Viscosity: 41.4 – 47

Waste material like oil, used batteries or others must be probably disposed and recycled according to the national regulations and brought to a recycling company if necessary.

The oil level in the oil tank should not be under the minimum mark for lifting load.

Refill oil from the filling point if necessary.

### **d. Checking electrical fuses**

Remove the plastic cover, the location of fuses is shown in Fig 15. Specification of the fuses is shown in Table 4.

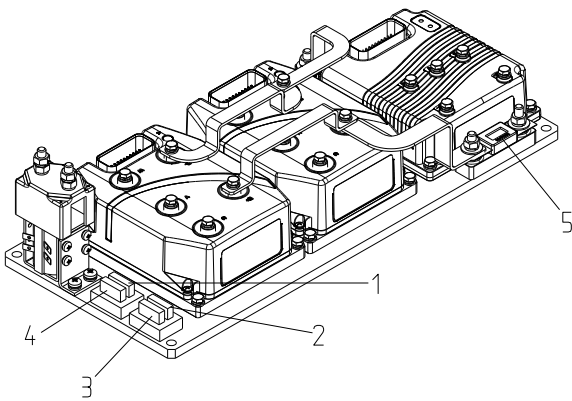

Table 4: Specification of the fuses

	Specification
FU 1	10A
FU 2	10A
FU 3	10A
FU 4	10A
FU 5	500A

Fig 15: Location of fuses

## 9. TROUBLE SHOOTING



- If the truck has malfunctions, follow the instructions mentioned in chapter 6.

Table 5: Trouble shooting

TROUBLE	CAUSE	MAINTENANCE
Load lifting failure	Load weight too high	Lift only the max. capacity, mentioned on the ID-plate.
	Battery discharged	Charge the battery.
	Lifting fuse failure	Check and eventually replace the lifting fuse.
	Hydraulic oil level too low	Check and eventually refill hydraulic oil.
	Oil leakage	Repair the hoses and/or the sealing of the cylinder.
Oil leakage from air suction	Excessive viscosity of oil	Reduce oil viscosity.
Truck operating failure	Battery is charging	Charge the battery completely and remove the main power plug from the socket.
	Battery not connected	Connect the battery correctly.
	The fuse is faulty	Check and eventually replace fuses.
	Battery discharged	Charge the battery.
	Emergency button is activated	Deactivate the button by inserting and pulling the knob.
Only travelling in one direction	The accelerator and the connections are damaged.	Check the accelerator and the connections.
The truck only travels very slowly	The battery is discharged.	Check the state of charge displayed on the battery indicator.
	The electromagnetic brake is engaged.	Check the electromagnetic brake.
	The relating tiller cables are disconnected or damaged	Check the tiller cables and connections.
	Electric system overheated	Stop using and cool down the truck.
	Heat sensor failure	Check and if necessary replace the heat sensor.
The truck starts up suddenly	The controller is damaged.	Replace the controller.
	The accelerator not moves back to its neutral position.	Repair or replace the accelerator.

# 10. WIRING/CIRCUIT DIAGRAM

## Electrical circuit diagram

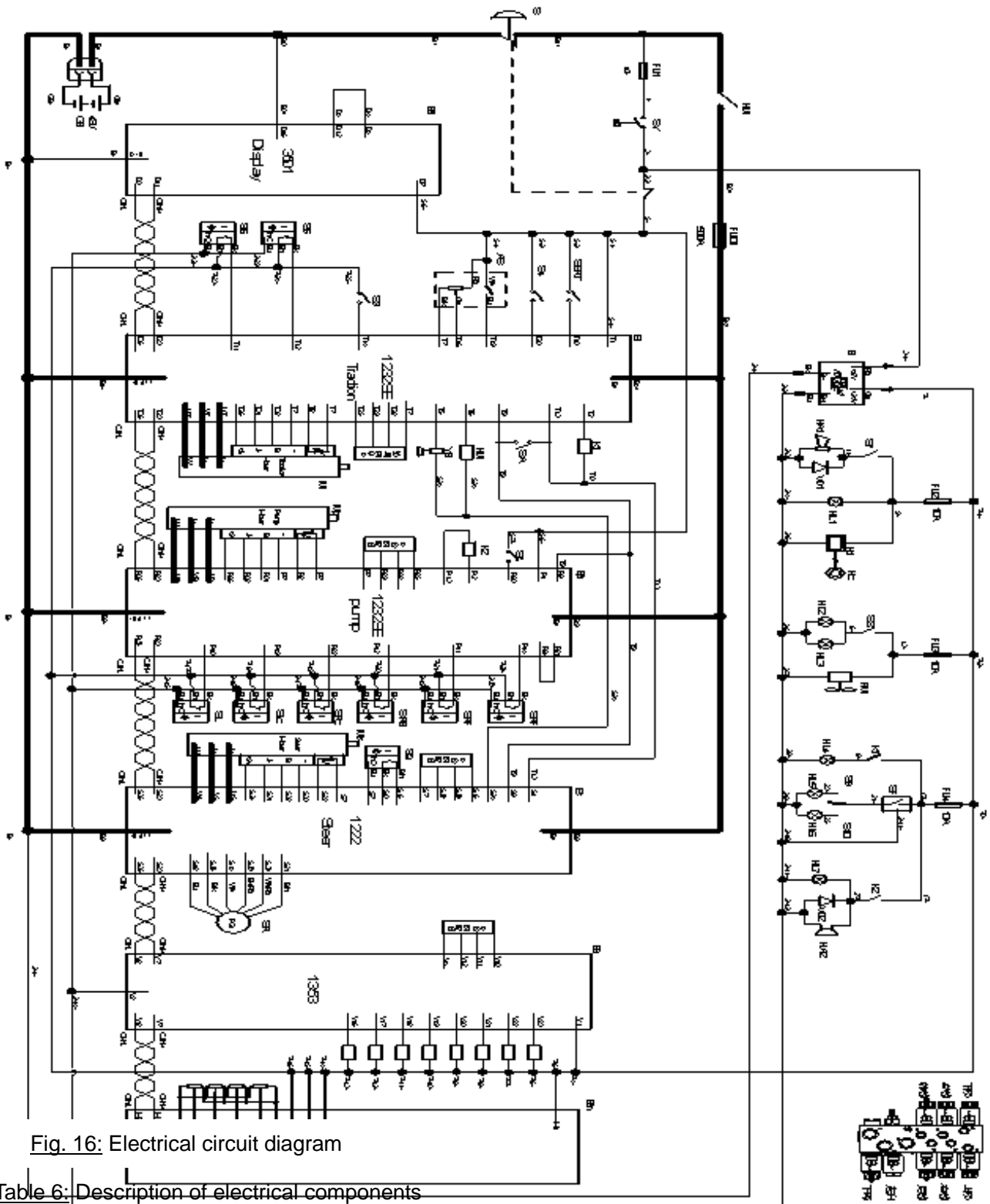

Fig. 16: Electrical circuit diagram

Table 6: Description of electrical components

Code	Item	Code	Item
GB	Battery 48V	S6	Battery extraction monitor switch

S	Emergency button	SL	Mast limit switch
Mt	Towering motor	SLC	Mast speed limit switch
Mp	Pump motor	SRF	Move forward limit switch
Ms	Steering motor	SRB	Move back limit switch
Et	Towering controller	SRC	Speed limit switch for moving back and forth
Ep	Pump controller	S7	Lithium battery switch
Es	Steering controller	D	Diode
Ed	Display	HA1	Horn
SQ	0°proximity switch	HL1	Warning signal light
SR	Steering wheel	HL2, HL3	Front lamp
SEAT	Seat switch	HL4	Brake lamp
FU01	Fuse 500A	FM	Fan
AS	Accelerator	HD	Display
SY	Key switch	HC	Camera
Kmt	Main contactor	SF	Flasher
YV	Lowering electromagnetic valve coil	HL5	Left signal light
YB	Electromagnetic brake	HL6	Right signal light
B	AC converter	HL7	Reversing light
SA	Pedal switch	HA2	Buzzer
FU1~FU4	Fuse 10A	K1	Brake relay
S1	Horn button	K2	Astern relay
S2	Lamp button	EM	CAN communication
S3	180°/ 360°switch	EV	Valve control
S4	Brake switch		
S5	Travel speed limit switch		

# 11. HYDRAULIC DIAGRAM

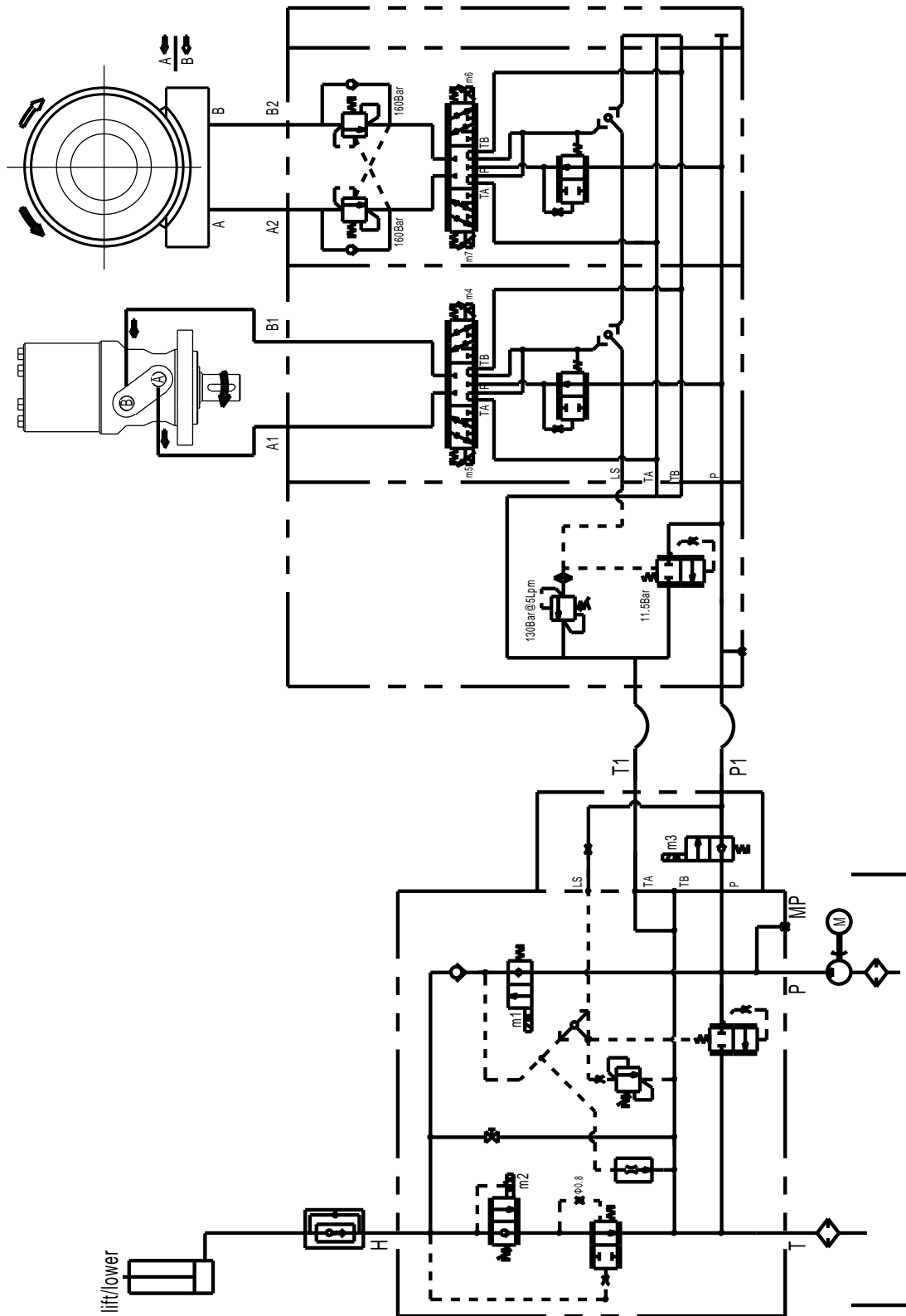

Fig. 17: Hydraulic diagram

## 12. DIAGNOSTICS AND TROUBLESHOOTING

These controllers detect a wide variety of faults or error conditions. Faults can be detected by the operating system or by the VCL code. This section describes the faults detected by the operating system. Diagnostics information can be obtained in either of two ways:

- (1) by reading the display on a hand-held or PC programmer or
- (2) by observing the fault codes issued by the Status LEDs. See Table 4 for a summary of LED display formats.

The pair of LEDs built into the controller (one red, one yellow) produce flash codes displaying all the currently set faults in a repeating cycle. Each code consists of two digits. The red light flashes once, indicating that the number of times the yellow light flashes below is the first digit of the fault code, and the red light flashes twice, indicating that the number of times the yellow light flashes below is the second digit of the fault code.

Example: red light flashes once, followed by yellow light flashes four times. Then the red light blinks twice, then the yellow light blinks twice, so the fault code is 42. Please refer to the list of fault information in this manual for relevant fault codes and causes.

In the fault menu of the programmer, the words **Throttle Wiper Low** will be displayed if the accelerator output is low.

The controller's two LEDs will display this repeating pattern:

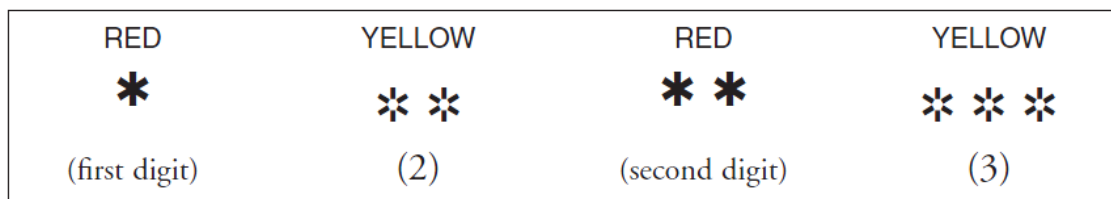

The numerical codes used by the yellow LED are listed in the troubleshooting table, which also lists possible fault causes and describes the conditions that set and clear each fault.

### Summary of LED display formats

The two LEDs have four different display modes, indicating the type of information they are providing:

DISPLAY	STATUS
Neither LED illuminated	Controller is not powered on/ vehicle has dead battery/ or severe damage.
Yellow LED flashing	Controller is operating normally.
Yellow and red LEDs both on solid	Controller is in Flash program mode.
Red LED light on solid	No software loaded, or an internal hardware fault detected by the Supervisor or Primary microprocessor. Cycle KSI to clear. Reload software or replace controller if necessary.



Red LED and yellow LED flash alternately

Controller has detected a fault. 2-digit code flashed by yellow LED identifies the specific fault; one or two flashes by red LED indicate whether first or second code digit will follow.

## Troubleshooting

The troubleshooting chart provides the following information on all the controller faults:

- fault code
- fault name as displayed on the programmer's LCD
- the effect of the fault
- possible causes of the fault
- fault set conditions
- fault clear conditions.

Whenever a fault is encountered and no wiring or vehicle fault can be found, shut off KSI and turn it back on to see if the fault clears. If it does not, shutoff KSI and remove the 35-pin connector. Check the connector for corrosion or damage, clean it if necessary, and re-insert it.

## 1232SE drive controller and pump motor controller troubleshooting table

CODE	PROGRAMMER LCD DISPLAY EFFECT OF FAULT	POSSIBLE CAUSE	SET / CLEAR CONDITIONS
12	<b>Controller Overcurrent</b> <i>ShutdownMotor;</i> <i>ShutdownMainContactor;</i> <i>ShutdownEMBrake;</i> <i>ShutdownThrottle;</i> <i>FullBrake.</i>	<ol style="list-style-type: none"> <li>External short of phase U,V, or W motor connections.</li> <li>Motor parameters are mis-tuned.</li> <li>Controller defective.</li> <li>Speed encoder noise problems.</li> </ol>	<p><i>Set:</i> Phase current exceeded the current measurement limit.</p> <p><i>Clear:</i> Cycle KSI.</p>
13	<b>Current Sensor Fault</b> <i>ShutdownMotor;</i> <i>ShutdownMainContactor;</i> <i>ShutdownEMBrake;</i> <i>ShutdownThrottle;</i> <i>FullBrake.</i>	<ol style="list-style-type: none"> <li>Leakage to vehicle frame from phase U, V, or W (short in motor stator).</li> <li>Controller defective.</li> </ol>	<p><i>Set:</i> Controller current sensors have invalid offset reading.</p> <p><i>Clear:</i> Cycle KSI.</p>
14	<b>Precharge Failed</b> <i>ShutdownMotor;</i> <i>ShutdownMainContactor;</i> <i>ShutdownEMBrake;</i> <i>ShutdownThrottle;</i> <i>FullBrake.</i>	<ol style="list-style-type: none"> <li>See Monitor menu » Battery: Capacitor Voltage.</li> <li>External load on capacitor bank (B+ connection terminal) that prevents the capacitor bank from charging.</li> </ol>	<p><i>Set:</i> The precharge failed to charge the capacitor bank.</p> <p><i>Clear:</i> Cycle Interlock input or use VCL function <i>Enable_Precharge()</i>.</p>
15	<b>Controller Severe Undertemp</b> <i>ShutdownMotor;</i> <i>ShutdownMainContactor;</i> <i>ShutdownEMBrake;</i> <i>ShutdownThrottle;</i> <i>FullBrake.</i>	<ol style="list-style-type: none"> <li>See Monitor menu » Controller: Temperature.</li> <li>Controller is operating in an extreme environment.</li> </ol>	<p><i>Set:</i> Heatsink temperature below -40°C.</p> <p><i>Clear:</i> Bring heatsink temperature above -40°C, and cycle interlock or KSI.</p>
16	<b>Controller Severe Overtemp</b> <i>ShutdownMotor;</i> <i>ShutdownMainContactor;</i> <i>ShutdownEMBrake;</i> <i>ShutdownThrottle;</i> <i>FullBrake.</i>	<ol style="list-style-type: none"> <li>See Monitor menu » Controller: Temperature.</li> <li>Controller is operating in an extreme environment.</li> <li>Excessive load on vehicle.</li> <li>Improper mounting of controller.</li> </ol>	<p><i>Set:</i> Heatsink temperature above +95°C.</p> <p><i>Clear:</i> Bring heatsink temperature below +95°C, and cycle interlock or KSI.</p>
17	<b>Severe B+ Undervoltage</b> <i>No drive torque.</i>	<ol style="list-style-type: none"> <li>Battery parameters are misadjusted.</li> <li>Non-controller system drain on battery.</li> <li>Battery resistance too high.</li> <li>Battery disconnected while driving.</li> <li>See Monitor menu » Battery: Capacitor Voltage.</li> <li>Blown B+ fuse or main contactor did not close.</li> </ol>	<p><i>Set:</i> Capacitor bank voltage dropped below the Severe Undervoltage limit (see page 25) with FET bridge enabled.</p> <p><i>Clear:</i> Bring capacitor voltage above Severe Undervoltage limit.</p>
17	<b>Severe KSI Undervoltage</b> <i>No action.</i>	<ol style="list-style-type: none"> <li>See Monitor menu » Battery: Keyswitch Voltage.</li> <li>Non-controller system drain on battery/ KSI circuit wiring.</li> <li>KSI disconnected while driving.</li> <li>Blown KSI fuse.</li> </ol>	<p><i>Set:</i> When below Brownout Voltage for 2 seconds (see Table D-1).</p> <p><i>Clear:</i> Bring KSI voltage above Brownout Voltage.</p>
18	<b>Severe B+ Overvoltage</b> <i>ShutdownMotor;</i> <i>ShutdownMainContactor;</i> <i>ShutdownEMBrake;</i> <i>ShutdownThrottle;</i> <i>FullBrake.</i>	<ol style="list-style-type: none"> <li>See Monitor menu » Battery: Capacitor Voltage.</li> <li>Battery parameters are misadjusted.</li> <li>Battery resistance too high for given regen current.</li> <li>Battery disconnected while regen braking.</li> </ol>	<p><i>Set:</i> Capacitor bank voltage exceeded the Severe Overvoltage limit (see page 25) with FET bridge enabled.</p> <p><i>Clear:</i> Bring capacitor voltage below Severe Overvoltage limit, and then cycle KSI.</p>

CODE	PROGRAMMER LCD DISPLAY EFFECT OF FAULT	POSSIBLE CAUSE	SET / CLEAR CONDITIONS
18	Severe KSI Overvoltage Shutdown Motor; Shutdown Main Contactor; Shutdown EM Brake; Shutdown Throttle; Full Brake.	1. Incorrect (to high) battery-voltage applied to KSI (pin 1) 2. See Monitor menu > Battery: Keyswitch Voltage. Note: Prevents the Main Contactor closure if KSI is greater than the Severe Overvoltage limit.	Set: KSI voltage exceeded Severe Overvoltage limit Clear: Bring KSI voltage below the Severe Overvoltage limit (see page 25, Severe Overvoltage)
22	Controller Overtemp Cutback Reduced drive and brake torque.	1. See Monitor menu > Controller: Temperature. 2. Controller is performance-limited at this temperature. 3. Controller is operating in an extreme environment. 4. Excessive load on vehicle. 5. Improper mounting of controller.	Set: Heatsink temperature exceeded 85°C. Clear: Bring heatsink temperature below 85°C.
23	B+ Undervoltage Cutback Reduced drive torque.	1. Normal operation. Fault indicates the batteries need recharging. Controller is performance limited at this voltage. 2. Battery parameters are misadjusted. 3. Non-controller system drain on battery. 4. Battery resistance too high. 5. Battery disconnected while driving. 6. See Monitor menu > Battery: Capacitor Voltage. 7. Blown B+ fuse or main contactor did not close.	Set: Capacitor bank voltage dropped below the Undervoltage limit (see page 25) with the FET bridge enabled. Clear: Bring capacitor voltage above the Undervoltage limit.
24	B+ Overvoltage Cutback Reduced brake torque. Note: This fault is declared only when the controller is running in regen.	1. Normal operation. Fault shows that regen braking currents elevated the battery voltage during regen braking. Controller is performance limited at this voltage. 2. Battery parameters are misadjusted. 3. Battery resistance too high for given regen current. 4. Battery disconnected while regen braking. 5. See Monitor menu > Battery: Capacitor Voltage.	Set: Capacitor bank voltage exceeded the Overvoltage limit (see page 25) with the FET bridge enabled. Clear: Bring capacitor voltage below the Overvoltage limit.
25	+5V Supply Failure None, unless a fault action is programmed in VCL.	1. External load impedance on the +5V supply (pin 26) is too low. 2. See Monitor menu > outputs: 5 Volts and Ext Supply Current.	Set: +5V supply (pin 26) outside the 5 V ± 10% range. Clear: Bring voltage within range.
26	Digital Out 6 Open/Short Digital Output 6 driver will not turn on.	1. External load impedance on Digital Output 6 driver (pin 19) is too low.	Set: Digital Output 6 (pin 19) current exceeded 1 Amp. Clear: Remedy the overcurrent cause and use the VCL function Set_DigOut() to turn the driver on again.
27	Digital Out 7 Open/Short Digital Output 7 driver will not turn on.	1. External load impedance on Digital Output 7 driver (pin 20) is too low.	Set: Digital Output 7 (pin 20) current exceeded 1 Amp. Clear: Remedy the overcurrent cause and use the VCL function Set_DigOut() to turn the driver on again.

CODE	PROGRAMMER LCD DISPLAY EFFECT OF FAULT	POSSIBLE CAUSE	SET / CLEAR CONDITIONS
28	<b>Motor Temp Hot Cutback</b> <i>Reduced drive torque.</i>	<ol style="list-style-type: none"> <li>1. Motor temperature is at or above the programmed Temperature Hot setting, and the current is being cutback.</li> <li>2. Motor Temperature Control Menu parameters are mis-tuned.</li> <li>3. See Monitor menu » Motor: Temperature and » Inputs: Analog2.</li> <li>4. If the application doesn't use a motor thermistor, Temp Compensation and Temp Cutback should be programmed Off.</li> </ol>	<p><i>Set:</i> Motor temperature is at or above the Temperature Hot parameter setting.</p> <p><i>Clear:</i> Bring the motor temperature within range.</p>
29	<b>Motor Temp Sensor Fault</b> <i>MaxSpeed reduced (LOS, Limited Operating Strategy), and motor temperature cutback disabled.</i>	<ol style="list-style-type: none"> <li>1. Motor thermistor is not connected properly.</li> <li>2. If the application doesn't use a motor thermistor, Motor Temp Sensor Enable should be programmed Off.</li> <li>3. See Monitor menu » Motor: Temperature and » Inputs: Analog2.</li> </ol>	<p><i>Set:</i> Motor thermistor input (pin 8) is at the voltage rail (0 V or 10 V).</p> <p><i>Clear:</i> Bring the motor thermistor input voltage within range.</p>
31	<b>Coil1 Driver Open/Short</b> <i>ShutdownDriver1.</i>	<ol style="list-style-type: none"> <li>1. Open or short on driver load.</li> <li>2. Dirty connector pins.</li> <li>3. Bad crimps or faulty wiring.</li> </ol>	<p><i>Set:</i> Driver 1 (pin 6) is either open or shorted. This fault can be set only when Main Enable = Off.</p> <p><i>Clear:</i> Correct open or short, and cycle driver.</p>
31	<b>Main Open/Short</b> <i>ShutdownMotor; ShutdownMainContactor; ShutdownEMBrake; ShutdownThrottle; FullBrake.</i>	<ol style="list-style-type: none"> <li>1. Open or short on driver load.</li> <li>2. Dirty connector pins.</li> <li>3. Bad crimps or faulty wiring.</li> </ol>	<p><i>Set:</i> Main contactor driver (pin 6) is either open or shorted. This fault can be set only when Main Enable = On.</p> <p><i>Clear:</i> Correct open or short, and cycle driver</p>
32	<b>Coil2 Driver Open/Short</b> <i>ShutdownDriver2.</i>	<ol style="list-style-type: none"> <li>1. Open or short on driver load.</li> <li>2. Dirty connector pins.</li> <li>3. Bad crimps or faulty wiring.</li> </ol>	<p><i>Set:</i> Driver 2 (pin 5) is either open or shorted. This fault can be set only when EM Brake Type = 0.</p> <p><i>Clear:</i> Correct open or short, and cycle driver.</p>
32	<b>EMBrake Open/Short</b> <i>ShutdownEMBrake; ShutdownThrottle; FullBrake.</i>	<ol style="list-style-type: none"> <li>1. Open or short on driver load.</li> <li>2. Dirty connector pins.</li> <li>3. Bad crimps or faulty wiring.</li> </ol>	<p><i>Set:</i> Electromagnetic brake driver (pin 5) is either open or shorted. This fault can be set only when EM Brake Type &gt;0.</p> <p><i>Clear:</i> Correct open or short, and cycle driver.</p>
33	<b>Coil3 Driver Open/Short</b> <i>ShutdownDriver3.</i>	<ol style="list-style-type: none"> <li>1. Open or short on driver load.</li> <li>2. Dirty connector pins.</li> <li>3. Bad crimps or faulty wiring.</li> </ol>	<p><i>Set:</i> Driver 3 (pin 4) is either open or shorted.</p> <p><i>Clear:</i> Correct open or short, and cycle driver.</p>
34	<b>Coil4 Driver Open/Short</b> <i>ShutdownDriver4.</i>	<ol style="list-style-type: none"> <li>1. Open or short on driver load.</li> <li>2. Dirty connector pins.</li> <li>3. Bad crimps or faulty wiring.</li> </ol>	<p><i>Set:</i> Driver 4 (pin 3) is either open or shorted.</p> <p><i>Clear:</i> Correct open or short, and cycle driver.</p>
35	<b>PD Open/Short</b> <i>ShutdownPD.</i>	<ol style="list-style-type: none"> <li>1. Open or short on driver load.</li> <li>2. Dirty connector pins.</li> <li>3. Bad crimps or faulty wiring.</li> </ol>	<p><i>Set:</i> Proportional driver (pin 2) is either open or shorted.</p> <p><i>Clear:</i> Correct open or short, and cycle driver.</p>
36	<b>Encoder Fault</b> <i>ShutdownEMBrake; Motor disabled.</i>	<ol style="list-style-type: none"> <li>1. Motor encoder failure.</li> <li>2. Bad crimps or faulty wiring.</li> <li>3. See Monitor menu » Motor: Motor RPM.</li> </ol>	<p><i>Set:</i> Motor encoder phase failure detected.</p> <p><i>Clear:</i> Either cycle KSI, or if parameter LOS Upon Encoder Fault= On and Interlock has been cycled, then the Encoder Fault is cleared and Encoder LOS fault (code 93) is set, allowing limited motor control.</p>
36	<b>Sin/Cos Sensor Fault</b> <i>ShutdownEMBrake; Motor disabled.</i>	<ol style="list-style-type: none"> <li>1. Sin/Cos sensor failure.</li> <li>2. Bad crimps or faulty wiring.</li> <li>3. See Monitor menu » Motor: Motor RPM.</li> </ol>	<p><i>Set:</i> Greater than Sin_Cos_Fault_Threshold % difference from expected value between two phases seen 5 times within one second.</p> <p><i>Clear:</i> Cycle KSI, or VCL reset, or Entry into LOS mode if enabled, (or entry into an ACIM auto-characterization).</p>

CODE	PROGRAMMER LCD DISPLAY EFFECT OF FAULT	POSSIBLE CAUSE	SET / CLEAR CONDITIONS
37	<b>Motor Open</b> <i>ShutdownMotor;</i> <i>ShutdownMainContactor;</i> <i>ShutdownEMBrake;</i> <i>ShutdownThrottle;</i> <i>FullBrake.</i>	<ol style="list-style-type: none"> <li>1. Motor phase is open.</li> <li>2. Bad crimps or faulty wiring.</li> </ol>	<p>Set: Motor phase U, V, or W detected open.</p> <p>Clear: Cycle KSI.</p>
38	<b>Main Contactor Welded</b> <i>ShutdownMotor;</i> <i>ShutdownMainContactor;</i> <i>ShutdownEMBrake;</i> <i>ShutdownThrottle;</i> <i>FullBrake.</i>	<ol style="list-style-type: none"> <li>1. Main contactor tips are welded closed.</li> <li>2. Motor phase U or V is disconnected or open.</li> <li>3. An alternate voltage path (such as an external precharge resistor) is providing a current to the capacitor bank (B+ connection terminal).</li> </ol>	<p>Set: Just prior to the main contactor dosing, the capacitor bank voltage (B+ connection terminal) was loaded for a short time and the voltage did not discharge.</p> <p>Clear: Cycle KSI</p>
39	<b>Main Contactor Did Not Close</b> <i>ShutdownMotor;</i> <i>ShutdownMainContactor;</i> <i>ShutdownEMBrake;</i> <i>ShutdownThrottle;</i> <i>FullBrake.</i>	<ol style="list-style-type: none"> <li>1. Main contactor did not close.</li> <li>2. Main contactor tips are oxidized, burned, or not making good contact.*</li> <li>3. External load on capacitor bank (B+ connection terminal) that prevents capacitor bank from charging.</li> <li>4. Blown B+ fuse.</li> </ol>	<p>Set: With the main contactor commanded closed, the capacitor bank voltage (B+ connection terminal) did not charge to B+.</p> <p>Clear: Cycle KSI.</p> <p>*New contactors may need to be cycled electrically &amp; mechanically to remove any non-conductive material on the tips. Use reduced voltage (e.g., 12V) to prevent tip damage through excessive arcing.</p>
41	<b>Throttle Wiper High</b> <i>ShutdownThrottle.</i>	<ol style="list-style-type: none"> <li>1. See Monitor menu &gt; Inputs:Throttle Pot.</li> <li>2. Throttle pot wiper voltage too high.</li> </ol>	<p>Set: Throttle pot wiper (pin 16) voltage is higher than the high fault threshold (can be changed with the VCL function <i>Setup_Pot_Faults()</i>).</p> <p>Clear: Bring throttle pot wiper voltage below the fault threshold.</p>
42	<b>Throttle Wiper Low</b> <i>ShutdownThrottle.</i>	<ol style="list-style-type: none"> <li>1. See Monitor menu &gt; Inputs:Throttle Pot.</li> <li>2. Throttle pot wiper voltage too low.</li> </ol>	<p>Set: Throttle pot wiper (pin 16) voltage is lower than the low fault threshold (can be changed with the VCL function <i>Setup_Pot_Faults()</i>).</p> <p>Clear: Bring throttle pot wiper voltage above the fault threshold.</p>
43	<b>Pot2 Wiper High</b> <i>FullBrake.</i>	<ol style="list-style-type: none"> <li>1. See Monitor menu &gt; Inputs: Pot2 Raw.</li> <li>2. Pot2 wiper voltage too high.</li> </ol>	<p>Set: Pot2 wiper (pin 17) voltage is higher than the high fault threshold (can be changed with the VCL function <i>Setup_Pot_Faults()</i>).</p> <p>Clear: Bring Pot2 wiper voltage below the fault threshold.</p>
44	<b>Pot2 Wiper Low</b> <i>FullBrake.</i>	<ol style="list-style-type: none"> <li>1. See Monitor menu &gt; Inputs: Pot2 Raw.</li> <li>2. Pot2 wiper voltage too low.</li> </ol>	<p>Set: Pot2 wiper (pin 17) voltage is lower than the low fault threshold (can be changed with the VCL function <i>Setup_Pot_Faults()</i>).</p> <p>Clear: Bring Pot2 wiper voltage above the fault threshold.</p>
45	<b>Pot Low OverCurrent</b> <i>ShutdownThrottle;</i> <i>FullBrake.</i>	<ol style="list-style-type: none"> <li>1. See Monitor menu &gt; Outputs: Pot Low.</li> <li>2. Combined pot resistance connected to pot low is too low.</li> </ol>	<p>Set: Pot low (pin 18) current exceeds 10 mA.</p> <p>Clear: Clear pot low overcurrent condition and cycle KSI.</p>
46	<b>EEPROM Failure</b> <i>ShutdownMotor;</i> <i>ShutdownMainContactor;</i> <i>ShutdownEMBrake;</i> <i>ShutdownThrottle;</i> <i>ShutdownInterlock;</i> <i>ShutdownDriver1;</i> <i>ShutdownDriver2;</i> <i>ShutdownDriver3;</i> <i>ShutdownDriver4;</i> <i>ShutdownPD;</i> <i>FullBrake.</i>	<ol style="list-style-type: none"> <li>1. Failure to write to EEPROM memory. This can be caused by EEPROM memory writes initiated by VCL, by the CAN bus, by adjusting parameters with the programmer, or by loading new software into the controller.</li> </ol>	<p>Set: Controller operating system tried to write to EEPROM memory and failed.</p> <p>Clear: Download the correct software (OS) and matching parameter default settings into the controller and cycle KSI.</p>

CODE	PROGRAMMER LCD DISPLAY EFFECT OF FAULT	POSSIBLE CAUSE	SET / CLEAR CONDITIONS
47	HPD/Sequencing Fault <i>ShutdownThrottle.</i>	<ol style="list-style-type: none"> <li>1. KSI, interlock, direction, and throttle inputs applied in incorrect sequence.</li> <li>2. Faulty wiring, crimps, or switches at KSI, interlock, direction, or throttle inputs.</li> <li>3. See Monitor menu → Inputs.</li> </ol>	<p><i>Set:</i> HPD (High Pedal Disable) or sequencing fault caused by incorrect sequence of KSI, interlock, direction, and throttle inputs.</p> <p><i>Clear:</i> Reapply inputs in correct sequence.</p>
47	Emer Rev HPD <i>ShutdownThrottle;</i> <i>ShutdownEMBrake.</i>	<ol style="list-style-type: none"> <li>4. Emergency Reverse operation has concluded, but the throttle, forward and reverse inputs, and interlock have not been returned to neutral.</li> </ol>	<p><i>Set:</i> At the conclusion of Emergency Reverse, the fault was set because various inputs were not returned to neutral.</p> <p><i>Clear:</i> If EMR_Interlock = On, clear the interlock, throttle, and direction inputs. If EMR_Interlock = Off, clear the throttle and direction inputs.</p>
49	Parameter Change Fault <i>ShutdownMotor;</i> <i>ShutdownMainContactor;</i> <i>ShutdownEMBrake;</i> <i>ShutdownThrottle;</i> <i>FullBrake.</i>	<ol style="list-style-type: none"> <li>1. This is a safety fault caused by a change in certain parameter settings so that the vehicle will not operate until KSI is cycled. For example, if a user changes the Throttle Type this fault will appear and require cycling KSI before the vehicle can operate.</li> </ol>	<p><i>Set:</i> Adjustment of a parameter setting that requires cycling of KSI.</p> <p><i>Clear:</i> Cycle KSI.</p>
51-67	OEM Faults <i>(See OEM documentation.)</i>	<ol style="list-style-type: none"> <li>1. These faults can be defined by the OEM and are implemented in the application-specific VCL code. See OEM documentation.</li> </ol>	<p><i>Set:</i> See OEM documentation.</p> <p><i>Clear:</i> See OEM documentation.</p>
68	VCL Run Time Error <i>ShutdownMotor;</i> <i>ShutdownMainContactor;</i> <i>ShutdownEMBrake;</i> <i>ShutdownThrottle;</i> <i>ShutdownInterlock;</i> <i>ShutdownDriver1;</i> <i>ShutdownDriver2;</i> <i>ShutdownDriver3;</i> <i>ShutdownDriver4;</i> <i>ShutdownPD;</i> <i>FullBrake.</i>	<ol style="list-style-type: none"> <li>1. VCL code encountered a runtime VCL error.</li> <li>2. See Monitor menu → Controller: VCL Error Module and VCL Error. This error can then be compared to the runtime VCL module ID and error code definitions found in the specific OS system information file.</li> </ol>	<p><i>Set:</i> Runtime VCL code error condition.</p> <p><i>Clear:</i> Edit VCL application software to fix this error condition; flash the new compiled software and matching parameter defaults; cycle KSI</p>
69	External Supply Out of Range <i>None, unless a fault action is programmed in VCL.</i>	<ol style="list-style-type: none"> <li>1. External load on the 5V and 12V supplies draws either too much or too little current.</li> <li>2. Fault Checking Menu parameters Ext Supply Max and Ext Supply Min are mis-tuned.</li> <li>3. See Monitor menu → Outputs: Ext Supply Current.</li> </ol>	<p><i>Set:</i> The external supply current (combined current used by the 5V supply [pin 26] and 12V supply [pin 25]) is either greater than the upper current threshold or lower than the lower current threshold. The two thresholds are defined by the External Supply Max and External Supply Min parameter settings (page 54).</p> <p><i>Clear:</i> Bring the external supply current within range.</p>
71	OS General <i>ShutdownMotor;</i> <i>ShutdownMainContactor;</i> <i>ShutdownEMBrake;</i> <i>ShutdownThrottle;</i> <i>ShutdownInterlock;</i> <i>ShutdownDriver1;</i> <i>ShutdownDriver2;</i> <i>ShutdownDriver3;</i> <i>ShutdownDriver4;</i> <i>ShutdownPD;</i> <i>FullBrake.</i>	<ol style="list-style-type: none"> <li>1. Internal controller fault.</li> </ol>	<p><i>Set:</i> Internal controller fault detected.</p> <p><i>Clear:</i> Cycle KSI.</p>
72	PDO Timeout <i>ShutdownThrottle;</i> CAN NMT State set to Pre-operational.	<ol style="list-style-type: none"> <li>1. Time between CAN PDO messages received exceeded the PDO Timeout Period.</li> </ol>	<p><i>Set:</i> Time between CAN PDO messages received exceeded the PDO Timeout Period.</p> <p><i>Clear:</i> Cycle KSI or receive CAN NMT message.</p>

<b>CODE</b>	<b>PROGRAMMER LCD DISPLAY EFFECT OF FAULT</b>	<b>POSSIBLE CAUSE</b>	<b>SET / CLEAR CONDITIONS</b>
73	<b>Stall Detected</b> <i>ShutdownEMBrake;</i> Motor disabled; Control Mode changed to LOS (Limited Operating Strategy).	<ol style="list-style-type: none"> <li>1. Stalled motor.</li> <li>2. Motor encoder failure.</li> <li>3. Bad crimps or faulty wiring.</li> <li>4. Problems with power supply for the motor encoder.</li> <li>5. See Monitor menu → Motor: Motor RPM.</li> </ol>	<p><i>Set:</i> No motor encoder movement detected.</p> <p><i>Clear:</i> Either cycle KSI, or if parameter LOS Upon Encoder Fault = On and Interlock has been cycled, then the Stall Detected fault is cleared and Encoder LOS fault (code 93) is set, allowing limited motor control.</p>
74	<b>Fault On Other Traction Controller</b>	<ol style="list-style-type: none"> <li>1. Dual Drive fault: see Dual Drive manual.</li> </ol>	
75	<b>Dual Severe Fault</b>	<ol style="list-style-type: none"> <li>1. Dual Drive fault: see Dual Drive manual.</li> </ol>	
77	<b>Supervisor Fault</b> <i>ShutdownMotor;</i> <i>ShutdownMainContactor;</i> <i>ShutdownEMBrake;</i> <i>ShutdownThrottle;</i> <i>ShutdownInterlock;</i> <i>ShutdownDriver1;</i> <i>ShutdownDriver2;</i> <i>ShutdownDriver3;</i> <i>ShutdownDriver4;</i> <i>ShutdownPD;</i> <i>FullBrake.</i>	<ol style="list-style-type: none"> <li>1. The Supervisor has detected a mismatch in redundant readings.</li> <li>2. Internal damage to Supervisor microprocessor.</li> <li>3. Switch inputs allowed to be within upper and lower thresholds for over 100 milliseconds. (for recurring errors, check the switches for moisture).</li> </ol>	<p><i>Set:</i> Mismatched redundant readings; damaged Supervisor; illegal switch inputs.</p> <p><i>Clear:</i> Check for noise or voltage drift in all switch inputs; check connections; cycle KSI.</p>
78	<b>Supervisor Incompatible</b> <i>ShutdownMotor;</i> <i>ShutdownMainContactor;</i> <i>ShutdownEMBrake;</i> <i>ShutdownThrottle;</i> <i>ShutdownInterlock;</i> <i>ShutdownDriver1;</i> <i>ShutdownDriver2;</i> <i>ShutdownDriver3;</i> <i>ShutdownDriver4;</i> <i>ShutdownPD;</i> <i>FullBrake.</i>	<ol style="list-style-type: none"> <li>1. The main OS is not compatible with the Supervisor OS.</li> </ol>	<p><i>Set:</i> Incompatible software.</p> <p><i>Clear:</i> Load properly matched OS code or update the Supervisor code; cycle KSI.</p>
82	<b>Bad Calibrations</b> <i>ShutdownMotor;</i> <i>ShutdownMainContactor;</i> <i>ShutdownEMBrake;</i> <i>ShutdownThrottle;</i> <i>FullBrake.</i>	<ol style="list-style-type: none"> <li>1. Internal controller fault.</li> </ol>	<p><i>Set:</i> Internal controller fault detection.</p> <p><i>Clear:</i> Cycle KSI.</p>
83	<b>Driver Supply</b> <i>ShutdownMotor;</i> <i>ShutdownMainContactor;</i> <i>ShutdownEMBrake;</i> <i>ShutdownThrottle;</i> <i>FullBrake.</i>	<ol style="list-style-type: none"> <li>1. Internal controller fault in the voltage supply for the driver circuits.</li> </ol>	<p><i>Set:</i> Internal controller fault detection.</p> <p><i>Clear:</i> Cycle KSI.</p>

CODE	PROGRAMMER LCD DISPLAY <i>EFFECT OF FAULT</i>	POSSIBLE CAUSE	SET / CLEAR CONDITIONS
87	<b>Motor Characterization Fault</b> <i>ShutdownMotor;</i> <i>ShutdownMainContactor;</i> <i>ShutdownEMBrake;</i> <i>ShutdownThrottle;</i> <i>FullBrake.</i>	1. Motor characterization failed during characterization process. See Monitor menu > Controller: Motor Characterization Error for cause: 0 = sequencing error. Normally caused by turning off Motor Characterization Test Enable before running the test. 1 = encoder signal seen but step size not auto-detected; set up Encoder Steps manually 2 = motor temp sensor fault 3 = motor temp hot cutback fault 4 = controller overtemp cutback fault 5 = controller undertemp cutback fault 6 = undervoltage cutback fault 7 = severe overvoltage fault 8 = encoder signal not seen, or one or both channels missing 9 = motor parameters out of characterization range 20 = Sin/Cos sensor not found 21 = phasing not detected 22 = Sin/Cos sensor characterization failure 23 = started characterization procedure while motor rotating.	<i>Set:</i> Motor characterization failed during the motor characterization process. Normally caused by turning off Motor_Characterization_Test_Enable before running test. Needs controller reset.  <i>Clear:</i> Correct fault; cycle KSI, or VCL reset.
88	<b>Encoder Pulse Count Fault</b> <i>ShutdownMotor;</i> <i>ShutdownMainContactor;</i> <i>ShutdownEMBrake;</i> <i>ShutdownThrottle;</i> <i>ShutdownInterlock;</i> <i>ShutdownDriver1;</i> <i>ShutdownDriver2;</i> <i>ShutdownDriver3;</i> <i>ShutdownDriver4;</i> <i>ShutdownPD;</i> <i>FullBrake.</i>	1. Encoder Steps parameter does not match the actual motor encoder.	<i>Set:</i> Detected wrong setting of the Encoder Steps parameter.  <i>Clear:</i> Ensure the Encoder Steps parameter matches the actual encoder; cycle KSI.
89	<b>Motor Type Fault</b> <i>ShutdownMotor;</i> <i>ShutdownMainContactor;</i> <i>ShutdownEMBrake;</i> <i>ShutdownThrottle;</i> <i>FullBrake.</i>	2. The Motor_Type parameter value is out of range.	<i>Set:</i> Motor_Type parameter is set to an illegal value.  <i>Clear:</i> Set Motor_Type to correct value and cycle KSI.



CODE	PROGRAMMER LCD DISPLAY EFFECT OF FAULT	POSSIBLE CAUSE	SET / CLEAR CONDITIONS
91	<b>VCL/OS Mismatch</b> <i>ShutdownMotor;</i> <i>ShutdownMainContactor;</i> <i>ShutdownEMBrake;</i> <i>ShutdownThrottle;</i> <i>ShutdownInterlock;</i> <i>ShutdownDriver1;</i> <i>ShutdownDriver2;</i> <i>ShutdownDriver3;</i> <i>ShutdownDriver4;</i> <i>ShutdownPD;</i> <i>FullBrake.</i>	1. The VCL software in the controller does not match the OS software in the controller.	<i>Set:</i> VCL and OS software do not match; when KSI cycles, a check is made to verify that they match and a fault is issued when they do not.  <i>Clear:</i> Download the correct VCL and OS software into the controller.
92	<b>EM Brake Failed to Set</b> <i>ShutdownEMBrake;</i> <i>ShutdownThrottle.</i> Position Hold is engaged when Interlock = On.	1. Vehicle movement sensed after the EM Brake has been commanded to set. 2. EM Brake will not hold the motor from rotating.	<i>Set:</i> After the EM Brake was commanded to set and time has elapsed to allow the brake to fully engage, vehicle movement has been sensed. <i>Clear:</i> 1. Activate the Throttle (EM Brake type 2). 2. Activate the Interlock (EM Brake type 1).
93	<b>Encoder LOS (Limited Operating Strategy)</b> Enter LOS control mode.	1. Limited Operating Strategy (LOS) control mode has been activated, as a result of either an Encoder Fault (Code 36) or a Stall Detected fault (Code 73). 2. Motor encoder failure. 3. Bad crimps or faulty wiring. 4. Vehicle is stalled.	<i>Set:</i> Encoder Fault (code 36) or Stall Detected (code 73) was activated, if parameter LOS Upon Encoder Fault = On and Interlock has been cycled, then the Encoder LOS (code 93) control mode is activated, allowing limited motor control. <i>Clear:</i> Cycle KSI or, if LOS mode was activated by the Stall Detected fault, clear by ensuring encoder senses proper operation, Motor RPM = 0, and Throttle Command = 0.
94	<b>Emer Rev Timeout</b> <i>ShutdownEMBrake;</i> <i>ShutdownThrottle.</i>	1. Emergency Reverse was activated and concluded because the EMR Timeout timer has expired. 2. The emergency reverse input is stuck On.	<i>Set:</i> Emergency Reverse was activated and ran until the EMR Timeout timer expired. <i>Clear:</i> Turn the emergency reverse input Off.
98	<b>Illegal Model Number</b> <i>ShutdownMotor;</i> <i>ShutdownMainContactor;</i> <i>ShutdownEMBrake;</i> <i>ShutdownThrottle;</i> <i>FullBrake.</i>	1. Model_Number variable contains illegal value. 2. Software and hardware do not match. 3. Controller defective.	<i>Set:</i> Illegal Model_Number variable; when KSI cycles, a check is made to confirm a legal Model_Number, and a fault is issued if one is not found. <i>Clear:</i> Download appropriate software for your controller model.
99	<b>Parameter Mismatch</b> <i>ShutdownMotor;</i> <i>ShutdownMainContactor;</i> <i>ShutdownEMBrake;</i> <i>ShutdownThrottle;</i> <i>FullBrake.</i>	1. Dual drive enabled on only one controller. 2. Incorrect position feedback type chosen for motor technology in use. 3. Dual drive is enabled in torque mode.	<i>Set:</i> When the Dual Drive software is enabled, the controller must be set to either Speed Mode Express or Speed Mode; otherwise this fault is set. Motor Technology=0 must be paired with Feedback Type=1, and Motor Technology=1 must be paired with Feedback Type=2; otherwise this fault is set. <i>Clear:</i> Adjust parameters to appropriate values and cycle KSI.

## 1222 Steering motor controller troubleshooting table

FLASH CODE	SUB CODE	NAME	POSSIBLE CAUSE	SET CONDITION	CLEAR CONDITION	STEER FAULT ACTION	TRACTION FAULT ACTION
11	1	Hardware Fault	An internal hardware error has been detected; controller defective.	Hardware error detected.	Cycle KSL.	Shutdown.	1 = Stop.
12	1	Controller Overcurrent 1	1. External short of phase U, V, or W motor connection. 2. Controller defective.	Controller hardware detected overcurrent condition.	Cycle KSL.	Shutdown.	1 = Stop.
12	2	Controller Overcurrent 2	1. External short of phase U, V, or W motor connection. 2. Motor parameters are mis-tuned. 3. Controller defective.	1. Phase current > 120% of base current limit 2. Phase current exceeded the current measurement limit.	Cycle KSL.	Shutdown.	1 = Stop.
13	1	Current Sensor Fault	1. Leakage to vehicle frame from phase U, V, or W (short in motor stator). 2. Controller defective.	Controller current sensors have invalid offset reading.	Cycle KSL.	Shutdown.	1 = Stop.
14	1	Precharge	1. External load on capacitor bank (B+ connection terminal) that prevents the capacitor bank from charging. 2. Controller defective.	Capacitor bank voltage does not complete the charge to minimum of 75% of the keyswitch voltage.	Cycle KSL.	Shutdown.	1 = Stop.
15	1	Controller Severe Undertemp	Controller is operating in an extreme environment.	Controller heatsink temperature is equal to or below -40°C.	Bring heatsink temp above -35°C.	Warning Only.	3 = No action.
16	1	Controller Severe Overtemp	1. Improper mounting of controller. 2. Excessive load on vehicle. 3. Controller is operating in an extreme environment.	Controller heatsink temperature is equal to or above 95°C.	Cycle KSL.	Warning then Shutdown.	1 = Stop.
17	1	Severe Undervoltage	1. Battery or battery cables or battery connections defective. 2. Excessive non-controller system drain on battery. 3. Battery disconnected while driving. 4. Blown B+ fuse or steer contactor did not close.	1. Capacitor bank voltage (B+ terminal) less than 12 V when Interlock = On. 2. Keyswitch voltage less than 12 V.	Cycle KSL.	Shutdown.	1 = Stop.
18	1	Severe Overvoltage	1. Battery or battery cable resistance too high for a given regen current. 2. Battery disconnected while regen braking.	Keyswitch or capacitor voltage (B+ terminal) greater than 65 V.	Cycle KSL.	Shutdown.	1 = Stop.

FLASH CODE	SUB CODE	NAME	POSSIBLE CAUSE	SET CONDITION	CLEAR CONDITION	STEER FAULT ACTION	TRACTION FAULT ACTION
22	1	Controller Overtemp	<ol style="list-style-type: none"> <li>1. Improper mounting or cooling of controller.</li> <li>2. Excessive load on vehicle.</li> <li>3. Controller operating in an extreme environment.</li> </ol>	Controller heatsink temperature is equal to or above 85°C.	Heatsink temp <85°C.	Warning Only.	2 = Reduce speed. (Max speed reduced linearly from 100% at 85°C to 0% at 95°C.)
25	1	5V Supply Failure	External load impedance on the +5V supply is too low.	5V supply is outside the 5V +/- 10% range.	Cycle KSI.	Hold then Shutdown.	1 = Stop.
26	1	10V Supply Failure	External load impedance on the +10V supply is too low.	10V supply is outside the 10V +/- 10% range.	Cycle KSI.	Warning then Shutdown.	1 = Stop.
27	1	Severe Motor Over Temp	<ol style="list-style-type: none"> <li>1. Motor is operating in an extreme environment.</li> <li>2. Motor Temperature Control parameters are mis-tuned.</li> </ol>	Sensor Enable = On and steer motor temperature > programmed Temperature Max.	Cycle KSI.	Warning then Shutdown.	1 = Stop.
28	1	Motor Temp Hot Cutback	<ol style="list-style-type: none"> <li>1. Motor is operating in an extreme environment.</li> <li>2. Motor Temperature Control parameters are mis-tuned.</li> </ol>	Sensor Enable = On and steer motor temperature > programmed Temperature Hot.	Steer motor temperature < programmed Temperature Hot.	Warning Only.	2 = Reduce speed. (Max speed reduced linearly from 100% at Temperature Hot to 0% at Temperature Max.)
29	1	Motor Temp Sensor Fault	<ol style="list-style-type: none"> <li>1. Motor thermistor is not connected properly.</li> <li>2. If the application does not use a motor thermistor, the Motor Temperature Sensor Enable parameter should be programmed Off.</li> </ol>	Motor temperature input is at the voltage rail (0 or 5V).	Motor temp input within the normal operating range.	Warning Only.	2 = Reduce speed. (Max speed reduced to Sensor Fault Traction Cutback.)
31	1	Contactors Open/Short	<ol style="list-style-type: none"> <li>1. Open or short on driver load.</li> <li>2. Dirty connector pins.</li> <li>3. Bad crimps or faulty wiring.</li> </ol>	Steer contactor driver is either open or shorted. This fault is set only when Contactor Control Type = 1 and Checks Enable = On.	Cycle KSI.	Warning then Shutdown.	1 = Stop.

FLASH CODE	SUB CODE	NAME	POSSIBLE CAUSE	SET CONDITION	CLEAR CONDITION	STEER FAULT ACTION	TRACTION FAULT ACTION
35	1	Fault Output Open/Short	<ol style="list-style-type: none"> <li>External load impedance on the fault output is too low.</li> <li>Controller defective.</li> </ol>	<p>The controller is unable to assert the fault output line:</p> <ol style="list-style-type: none"> <li>The Fault Output= On and the fault output voltage is not within 5V of the KSI voltage.</li> <li>The Fault Output= Off and the fault output voltage is greater than 80% of KSI voltage.</li> <li>The Fault Output= On and the fault output voltage is less than 4 V.</li> </ol>	Cycle KSI.	Warning then Shutdown.	1 = Stop.
36	1	Motor Stalled	<ol style="list-style-type: none"> <li>Stalled steer motor.</li> <li>Steer motor encoder failure.</li> <li>Bad crimps or faulty wiring.</li> <li>Problems with power supply of the steer motor encoder.</li> </ol>	<p>The motor has been commanded to move at more than 2.5% of the Max Motor Speed or at more than 95% of the available motor current when the motor speed is less than the programmed Stall Speed for the programmed Stall Time.</p> <ol style="list-style-type: none"> <li>After the steer contactor closes but before operation starts, the motor is checked for an open phase by running a DC current out of phase U and ensuring the current is measured back on both phase V and phase W. The fault is set if the check fails.</li> <li>When the motor is running, one phase averages less than 1 A while the other phases average more than 4 A for 256 ms when the electrical frequency is greater than 1 Hz and has not changed sign.</li> </ol>	Cycle KSI.	Warning then Shutdown.	1 = Stop.
37	1	Motor Open	<ol style="list-style-type: none"> <li>Motor phase is open.</li> <li>Bad crimps or faulty motor cable wiring.</li> <li>Controller defective.</li> </ol>	<ol style="list-style-type: none"> <li>After the steer contactor closes but before operation starts, the motor is checked for an open phase by running a DC current out of phase U and ensuring the current is measured back on both phase V and phase W. The fault is set if the check fails.</li> <li>When the motor is running, one phase averages less than 1 A while the other phases average more than 4 A for 256 ms when the electrical frequency is greater than 1 Hz and has not changed sign.</li> </ol>	Cycle KSI.	Warning then Shutdown.	1 = Stop.
38	1	Contactor Welded	<ol style="list-style-type: none"> <li>Steer contactor tips are welded closed.</li> <li>An alternative voltage path (such as an external precharge resistor) is providing a current to the capacitor bank (B+ terminal).</li> </ol>	<p>The steer contactor tips are shorted when the contactor is supposed to be open. This fault is set only when Contactor Control Type= 1 and Checks Enable= On. The weld check is done in Steer Contactor State = 3 (Opening) when DC current is applied to the motor. The fault will be set if the difference between the capacitor bank and keyswitch voltages does not exceed 2V.</p>	Cycle KSI.	Shutdown.	1 = Stop.

FLASH CODE	SUB CODE	NAME	POSSIBLE CAUSE	SET CONDITION	CLEAR CONDITION	STEER FAULT ACTION	TRACTION FAULT ACTION
39	1	Contact Opened	<ol style="list-style-type: none"> <li>Steer contactor was closed temporarily but then opened.</li> <li>Steer contactor tips are oxidized.</li> <li>An external load on the capacitor bank (B+ terminal) that prevents the bank from charging.</li> </ol>	The steer contactor was closed, but detected open. This fault is set only when Contactor Control Type= 1 and Checks Enable= On. In Contactor State =2 (Closed), the fault will be set if the capacitor bank and keyswitch voltages differ by more than 5 V.	Cycle KSL.	Warning then Shutdown.	1 = Stop.
39	2	Contact Did Not Close	<ol style="list-style-type: none"> <li>Steer contactor did not close.</li> <li>Steer contactor tips are oxidized.</li> <li>An external load on the capacitor bank (B+ terminal) that prevents the bank from charging.</li> </ol>	The steer contactor did not close when commanded. This fault is set only when Contactor Control Type = 1 and Checks Enable= On. In Contactor State= 1 (Closing), the fault will be set if the capacitor bank and keyswitch voltages differ by more than 2 V.	Cycle KSL.	Shutdown.	1 = Stop.
41	1	Command Analog1 Out of Range	Command input device's Analog 3 input (pin 8) is out of range.	Analog1 voltage > Analog1 Fault Max or Analog1 voltage < Analog1 Fault Min. The fault is checked only if Command Input Device= 0, 2, or 3.	Cycle KSL.	Hold then Shutdown.	1 = Stop.
42	1	Command Analog3 Out of Range	Command input device's Analog 3 input (pin 19) is out of range.	Analog3 voltage > Analog3 Fault Max or Analog3 voltage < Analog3 Fault Min. The fault is checked only if Command Input Device= 0, 2, or 3.	Cycle KSL.	Hold then Shutdown.	1 = Stop.
43	1	Feedback Analog5 Out of Range	Position feedback device's Analog 5 input (pin 16) is out of range.	Analog5 voltage > Analog5 Fault Max or Analog5 voltage < Analog5 Fault Min. The fault is checked only if Position Feedback Device= 0, 2, or 3.	Cycle KSL.	Hold then Shutdown.	1 = Stop.
44	1	Feedback Analog6 Out of Range	Position feedback device's Analog 6 input (pin 17) is out of range.	Analog6 voltage > Analog6 Fault Max or Analog6 voltage < Analog6 Fault Min. The fault is checked only if Position Feedback Device= 0, 2, or 3.	Cycle KSL.	Hold then Shutdown.	1 = Stop.
45	1	CAN Not Operational	1222 CAN NMT State did not go operational within 80 ms of interlock being applied.	This check is made only when the parameter CAN Required = On. With Interlock = On for 80 ms, the CAN NMT State is ⇄ Operational.	Cycle KSL.	Warning and drop fault output.	1 = Stop.

FLASH CODE	SUB CODE	NAME	POSSIBLE CAUSE	SET CONDITION	CLEAR CONDITION	STEER FAULT ACTION	TRACTION FAULT ACTION
46	1	EEPROM CRC Fault	<ol style="list-style-type: none"> <li>1. New software loaded into EEPROM memory.</li> <li>2. Try using function "Restore to Factory Defaults" to clear fault.</li> <li>3. Controller defective.</li> </ol>	Error in EEPROM CRC calculation.	Cycle KSI.	Shutdown.	1 = Stop.
47	1	Sin/Cos Command Sensor	<ol style="list-style-type: none"> <li>1. Sin/Cos Sensor defective.</li> <li>2. Sin/Cos Sensor parameters are mis-tuned.</li> </ol>	The Analog 1 and Analog 3 inputs do not match the expected sine and cosine signals. They must be within the parameter Fault Volts of the ideal waveform as defined by the Gain and Offset parameters.	Cycle KSI.	Hold then Shutdown.	1 = Stop.
47	2	Sawtooth Command Sensor	<ol style="list-style-type: none"> <li>1. Sawtooth Sensor defective.</li> <li>2. Sawtooth Sensor parameters are mis-tuned.</li> </ol>	The Analog 1 and Analog 3 inputs do not match the expected sawtooth waveform. They must be within the parameter Command Device * 3 - Sawtooth Sensor * Tolerance of the ideal 180° offset. ABS(ABS(Analog1-Analog3)-0.5*(MaxVolts+MinVolts))>Sawtooth Tolerance for 60 ms.	Cycle KSI.	Hold then Shutdown.	1 = Stop.
48	1	Sin/Cos Feedback Sensor	<ol style="list-style-type: none"> <li>1. Sin/Cos Sensor defective.</li> <li>2. Sin/Cos Sensor parameters are mis-tuned.</li> </ol>	The Analog 5 and Analog 6 inputs do not match the expected sine and cosine signals. They must be within the parameter Fault Volts of the ideal waveform as defined by the Gain and Offset parameters.	Cycle KSI.	Hold then Shutdown.	1 = Stop.
48	2	Sawtooth Feedback Sensor	<ol style="list-style-type: none"> <li>1. Sawtooth Sensor defective.</li> <li>2. Sawtooth Sensor parameters are mis-tuned.</li> </ol>	The Analog 5 and Analog 6 inputs do not match the expected sawtooth waveform. They must be within the parameter Feedback Device * 3 - Sawtooth Sensor * Tolerance of the ideal 180° offset. ABS(ABS(Analog5-Analog6)-0.5*(MaxVolts+MinVolts))>Sawtooth Tolerance for 60 ms.	Cycle KSI.	Hold then Shutdown.	1 = Stop.

FLASH CODE	SUB CODE	NAME	POSSIBLE CAUSE	SET CONDITION	CLEAR CONDITION	STEER FAULT ACTION	TRACTION FAULT ACTION
49	1	Parameter Change Fault	A parameter value or the software was changed that required a power cycle. This fault is set automatically to force the vehicle operator to cycle power, for safety purposes.	<ol style="list-style-type: none"> <li>1. A parameter was changed that requires a power cycle. See PCF column in Sec. 3 (Programmable Parameter Menus) to identify the parameters that will cause a parameter change fault.</li> <li>2. A new software application was loaded that caused the parameter values to be overwritten, requiring a power cycle.</li> <li>3. A device using the serial interface (such as the 1313) is requesting an out-of-range parameter change.</li> </ol>	Cycle KSI.	Shutdown.	1 = Stop.
51	1	Interlock Switch Supervision	<ol style="list-style-type: none"> <li>1. When the interlock switch inputs are a crossed configuration (N.O. and N.C.), the two inputs are checked. A fault is set if Switch 1 (pin 9) = Switch 3 (pin 11).</li> <li>2. Interlock switch defective.</li> </ol>	Interlock Input 1 = Interlock Input 3. The fault is checked only when Interlock Type=2 (crossed polarity).	Interlock Input 1 ↔ Interlock Input 3.	Interlock = Off.	1 = Stop.
52	1	Home Switch Supervision	<ol style="list-style-type: none"> <li>1. When the wheel position is not close to home, the redundant home switch inputs are checked and a fault is set if they disagree.</li> <li>2. Home switch defective.</li> <li>3. For 360° steering, parameter Homing Cam Angle (deg) not set correctly.</li> </ol>	<ol style="list-style-type: none"> <li>1. Homing Input Type = 1 (crossed polarity) and Switch2 = Switch4 and the position from home is &gt; Home Reference Tolerance.</li> <li>2. Homing Input Type = 2 (same polarity) and Switch2 ↔ Switch4 and the position from home is &gt; Home Reference Tolerance.</li> </ol>	Cycle KSI.	Warning then Shutdown.	1 = Stop.
53	1	Home Position Not Found	Home switch defective.	During homing (Steer Command State=2), the home position was not found after traveling 180° (360° in the case of 360° steering) or within the programmed Homing Timeout time.	Cycle KSI.	Shutdown.	1 = Stop.
54	1	Home Reference Tolerance Fault	<ol style="list-style-type: none"> <li>1. Home switch defective.</li> <li>2. For 360° steering, parameter Homing Cam Angle (deg) not set correctly.</li> </ol>	During steering (Steer Command State=4), the wheel position at which the Home variable changes is further than the parameter Supervision * Home Reference Tolerance from the original position found during homing.	Cycle KSI.	Warning then Shutdown.	1 = Stop.

FLASH CODE	SUB CODE	NAME	POSSIBLE CAUSE	SET CONDITION	CLEAR CONDITION	STEER FAULT ACTION	TRACTION FAULT ACTION
55	1	Steer Command Supervision	Command input device defective.	Steer Command differs from Steer Command2 by more than the programmed Steer Command Tolerance. These command signals are checked by both the main and supervisor processors if the Device State = 5 (Operation Enabled). Note: This check is not performed if Supervision Input Device = 5.	Cycle KSI.	Hold then Shutdown.	1 = Stop.
56	1	Wheel Position Supervision	Position feedback device defective.	1. Wheel Position differs from Wheel Position2 by more than the Wheel Position Tolerance for 80 ms. These feedback signals are checked by both the main and supervisor processors if the Device State = 5 (Operation Enabled). 2. Wheel Position differs from Encoder3 Position by more than the Encoder Position Tolerance. These feedback signals are checked by only the main processor if the Device State = 5 (Operation Enabled). Note: This check is not performed if Supervision Feedback Device = 4.	Cycle KSI.	Hold then Shutdown.	1 = Stop.
69	1	5V Current Out of Range	The external load on the 5V supply is drawing either too much or too little current.	The measured current of the +5V supply (pins 21 and 3-4) is less than the parameter 5V Current Min or greater than the parameter 5V Current Max.	Cycle KSI.	Hold then Shutdown.	1 = Stop.
71	1	Software Fault 1	Reserved for future use.	—	—	—	—
71	2	Software Fault 2	1. Software defective. 2. Controller defective.	1. Unexpected software value. 2. Failure to send a CAN SDO message response.	Cycle KSI.	Shutdown.	1 = Stop.
71	3	Software Fault 3	Reserved for future use.	—	—	—	—
71	4	Software Fault 4	1. Software defective. 2. Controller defective.	Task overrun.	Cycle KSI.	Shutdown.	1 = Stop.



FLASH CODE	SUB CODE	NAME	POSSIBLE CAUSE	SET CONDITION	CLEAR CONDITION	STEER FAULT ACTION	TRACTION FAULT ACTION
71	5	Software Fault 5	1. Software defective. 2. Controller defective.	An internal micro-to-micro communication error.	Cycle KSI.	Shutdown.	1 = Stop.
72	1	PDO1 Timeout	Communication between the traction controller and the 1222 has halted.	Time between PDO1 messages received exceeds the PDO1 Timeout Time.	Cycle KSI.	Warning then Shutdown.	1 = Stop.
72	2	PDO2 Timeout	Communication from the CAN device sending the PDO2 message to the 1222 has halted.	Time between PDO2 messages received exceeds the PDO2 Timeout Time.	Cycle KSI.	Warning then Shutdown.	1 = Stop.
72	3	PDO3 Timeout	Communication from the CAN device sending the PDO3 message to the 1222 has halted.	Time between PDO3 messages received exceeds the PDO3 Timeout Time.	Cycle KSI.	Warning then Shutdown.	1 = Stop.
72	4	PDO4 Timeout	Communication from the CAN device sending the PDO4 message to the 1222 has halted.	Time between PDO4 messages received exceeds the PDO4 Timeout Time.	Cycle KSI.	Warning then Shutdown.	1 = Stop.
73	1	Following Error	1. Position feedback device defective. 2. Steer motor stalled. 3. Steer motor encoder failed.	This fault is checked by the main micro only when the Steering Command State = 4 (Steering). A fault is set if the Error Tolerance (deg) is exceeded and the steered wheel is not moving in the right direction with a Wheel Speed (deg/s) equal to or greater than the Speed Tolerance (deg/s) for longer than the Following Error Time.	Cycle KSI.	Warning then Shutdown.	1 = Stop.
74	1	Hardware Software Mismatch	1. New software loaded. 2. Controller hardware cannot use the loaded software.	1. The software is not compatible with the controller hardware. 2. The software loaded into either or both microprocessors is incorrect.	Cycle KSI.	Shutdown.	1 = Stop.

FLASH CODE	SUB CODE	NAME	POSSIBLE CAUSE	SET CONDITION	CLEAR CONDITION	STEER FAULT ACTION	TRACTION FAULT ACTION
75	1	Parameter Conflict	<ol style="list-style-type: none"> <li>Parameter settings are in conflict with each other.</li> <li>Parameter setting out of range.</li> </ol>	<ol style="list-style-type: none"> <li>Command Input Device = 1 and Vehicle Configuration * Traction Speed Input * Input Type = 1.</li> <li>Vehicle Configuration * Nominal Voltage is out of range (2.4-48 V).</li> <li>Motor Control Tuning * Motor Type is out of range (0-22).</li> <li>Motor * Temperature Control * Sensor Type is out of range (0-5).</li> <li>Command Input Device * 0-Analog1 and 3 * Analog1 Left, Center, and Right must be in ascending or descending order.</li> <li>Command Input Device * 0-Analog1 and 3 * Analog3 Left, Center, and Right must be in ascending or descending order.</li> <li>Feedback Device * 0-Analog5 and 6 * Analog5 Left Stop, Center, and Right Stop must be in ascending or descending order.</li> <li>Feedback Device * 0-Analog5 and 6 * Analog6 Left Stop, Center, and Right Stop must be in ascending or descending order.</li> <li>Command Device * Command Map * Left Stop (deg) or Right Stop (deg) = 0.</li> </ol>	Cycle KSI.	Shutdown.	1 = Stop.

## 13. Declaration of Conformity (valid for sale in the EU)

### **[GB] CE Declaration of Conformity**

The signatory hereby declares that the specified machine conforms to the EU Directive 2006/42/EC (Machine Directive) and 2014/30/EU (Electro-Magnetic Compatibility, EMC) including their amendments as translated into national legislation of the member countries. The signatory is individually authorized to compile the technical documents.

### **[D] EG-KONFORMITÄTSEKTLÄRUNG**

Der Unterzeichner bescheinigt hiermit, dass die im Einzelnen bezeichnete Maschine den Europäischen Richtlinien 2006/42/EG (Maschinenrichtlinie) und 2014/30/EU (Elektromagnetische Verträglichkeit - EMV) einschließlich deren Änderungen sowie dem entsprechenden Rechtserlaß zur Umsetzung der Richtlinien in nationales Recht entspricht. Der Unterzeichner ist bevollmächtigt, die technischen Unterlagen zusammenzustellen.

### **[E] DECLARACIÓN DE CONFORMIDAD CE**

El signatario certifica por medio de la presente que la máquina especificada cumple con las Normas Europeas 2006/42/CE (Normativa para maquinarias) y 2014/30/EU (Compatibilidad electromagnética), incluyendo sus respectivas modificaciones, así como con el decreto-ley para la adaptación de las normas al derecho nacional. El signatario dispone de una autorización individual que le permite compilar la documentación técnica.

### **[F] DECLARATION DE CONFORMITE CE**

Par la présente déclaration, les soussignés certifient que le machines spécifié ci-dessus est conforme à la loi et aux directives européennes 2006/42/CE (directive sur les machines) et 2014/30/EU (compatibilité électromagnétique - CEM), y compris aux modifications qui y sont apportées et à l'arrêté autorisant sa transposition en droit national. Chaque signataire est habilité à établir individuellement la documentation technique.

### **[NL] EG-KONFORMITEITSVERKLARING**

Ondergetekenden verklaren hierbij dat - volgens de nationale wetgeving van de Lidstaten - de hierboven vermelde opgegeven machina beantwoordt aan de bepalingen qua veiligheid bij machines (EG richtlijn 2006/42/EC) en electro-magnetische compatibiliteit (EG richtlijn 2014/30/EU).

Ondergetekenden zijn ieder individueel gemachtigd het technisch dossier samen te stellen.

### **[P] DECLARAÇÃO DE CONFORMIDADE CE**

Pela presente, os signatários certificam que o máquina especificado está conforme às Directivas Europeias 2006/42/CE („Máquinas“) e 2014/30/EU („Inocuidade Electromagnética - IEM“), incluindo as alterações das mesmas e o respectivo decreto-lei para a transposição em lei nacional. Cada um dos signatários está autorizado a proceder à elaboração da documentação técnica.

### **[I] DICHIARAZIONE DI CONFORMITÀ CE**

I sottoscritti dichiarano che il veicolo per trasporti interni a macchina specificato soddisfa le Direttive Europee 2006/42/EC (Direttiva Macchine) e 2014/30/EU (Compatibilità elettromagnetica - EMV) comprese le relative modifiche, come pure il rispettivo decreto legislativo per la conversione delle direttive in diritto nazionale. I sottoscritti sono singolarmente autorizzati alla creazione della documentazione tecnica.

### **[BG] ЕВРОПЕЙСКА ОБЩНОСТ - ДЕКЛАРАЦИЯ ЗА СЪОТВЕТСТВИЕ**

Подписаните удостоверяват с настоящето, че подробно описаното машина средство отговаря на европейския норматив 2006/42/EG (норматив за машини) и на 2014/30/EU (електро-магнетична съвместимост), включително с техните промени, както и на съответния указ за прилагане на нормативите в националното право. Подписаните при това са упълномощени поотделно да съставят техническата документация.

### **[CZ] EG - PROHLÁŠENÍ O SHODĚ**

Níže podepsaný tímto potvrzuje, že podrobný popis uvedené stroje odpovídá Evropským směrnícím 2006/42/EC (směrnice pro stroje) a 2014/30/EU (elektromagnetická interference - EMV) včetně jejich pozdějších úprav, jakož i příslušným právním výnosům pro uplatnění příslušné směrnice v rámci národního práva. Každý z podepsaných jsou jednotlivě způsobilí k vytvoření technických podkladů.

### **[DK] EF-OVERENSSTEMMELSEERKLÆRING**

Undertegnede attesterer hermed, at det specificerede maskine stemmer overens med de Europæiske Direktiver 2006/42/EU (maskindirektiv) og 2014/30/EU (elektromagnetisk kompatibilitet - EMC) samt med den modsvarende lovgivning til implementering af direktiver i den nationale lovgivning. De undertegnede er hver for sig beføjede til at sammenstille de tekniske dokumenter.

### **[EST] EL vastavusavaldus**

Allakirjutatud tõendavad käesolevaga, et üksikasjaliselt kirjeldatud täpsustatud masin vastab Euroopa direktiividele 2006/42/EÜ (Direktiiv masinate kohta) ja 2014/30/EU (Elektromagnetiline sobivus - EMS) kaasa arvatud nende muudatused ja nendele vastavatele õigusmäärustele direktiivide muutmiseks siseriiklikuks õiguseks. Iga allakirjutatu üksikult on volitatud koostama tehnilist dokumentatsiooni.

### **[FIN] EU-YHDENMUKAISUUSSELÖSTUS**

Allekirjoittaneet todistavat täten, että kukin erikseen mainittu omalla voimalla laitteella varustettu tehdaskone vastaa EU-direktiivien 2006/42/EC (koneenrakennusdirektiivi) ja 2014/30/EU (sähkömagneettinen yhteensopivuus – EMC) määräyksiä sekä niiden muutoksia ja niiden kansalliseen lainsäädäntöön soveltamista koskevaa oikeussäätöä. Jokaisella allekirjoittaneista on oikeus itsenäisesti laatia asiaankuuluvia teknisiä asiakirjoja.

### **[GR] ΔΗΛΩΣΗ ΣΥΜΜΟΡΦΩΣΗΣ ΕΟΚ**

Οι υπογράφωντες βεβαιώνουν διά της παρούσης ότι το συγκεκριμένο μηχάνημα συμμορφώνεται προς την Κοινοτική Οδηγία 2006/42/ΕΚ («Μηχανήματα») και 2014/30/ΕU (Ηλεκτρομαγνητικής Συμβατότητας, ΗΜΣ), καθώς και οι τροποποιήσεις τους, όπως μεταφράστηκε στην εθνική νομοθεσία των χωρών μελών. Οι υπογράφωντες είναι σε κάθε περίπτωση εξουσιοδοτημένοι ατομικά να καταρτίσουν τα τεχνικά έγγραφα.

### **[H] EU KONFORMITÄSI NYILATKOZAT**

Alulírottak ezennel igazolják, hogy a részletesen leírt a megadott gép megfelel a 2006/42/EC (Gép-Irányelv) és a 2014/30/EU (Elektromágneses összeférhetőség - EMV) Európai Irányelveknek, beleértve azok módosításait, valamint az irányelvek nemzeti jogba történő átültetésére irányuló megfelelő jogi rendelkezést. Továbbá az alulírottak mindegyike rendelkezik meghatalmazással arra nézve, hogy összeállíthatja a műszaki dokumentációt.

### **[LT] ES atitikimø deklaracija**

Žemiau pasirašę asmenys patvirtina, kad atskirai aprašytas nurodyta mašina atitinka Europos Sąjungos direktyvas 2006/42/EB (Mašinų direktyva) ir 2014/30/EU (Elektromagnetinis suderinamumas – EMS) įskaitant jų pakeitimus, o taip pat ir atitinkamą teisės aktą dėl direktyvų įgyvendinimo nacionalinėje teisėje. Kiekvienas iš pasirašiusių asmenų turi teisę ruošti techninę dokumentaciją.

### **[LV] ES atbilstības deklarācija**

Ar zemāk redzamajiem parakstiem tiek apliecināts, ka norādīts mašina atbilst Eiropas Savienības normatīvām 2006/42/EG (Mašīnu normatīvas) un 2014/30/EU (Elektromagnētiskā atbilstība – EMV), ieskaitot to izmaiņas, kā arī atbilstošos tiesiskos rīkojumus normatīvu pielāgošanai nacionālajai likumdošanai. Parakstu īpašnieki ir atsevišķi pilnvaroti sastādīt tehniskās dokumentācijas.

### **[N] EU-KONFORMITETSERKLÆRING**

Undertegnede bekræfter hermed at de enkelte betegnede maskin med kraftdrift tilsvare de europeiske retningslinjene 2006/42/EC (maskinretningslinje) og 2014/30/EU (elektromagnetisk fordraglighed - EMV) inklusiv disses endringer og den tilsvarende rettsforordning til omsetning av nasjonal rett. Hver undertegnede er fullmektig til å sette sammen de tekniske dokumentene.

## **[PL] DEKLARACJA ZGODNOŚCI WE**

Niżej podpisani deklaruja, że poniżej opisana maszyna spełnia wymagania określone w dyrektywach Europejskich 2006/42/EC (Dyrektywa Maszynowa) i 2014/30/EU (Kompatybilności elektromagnetycznej - EMC) wraz z ich późniejszymi zmianami oraz odpowiednimi rozporządzeniami mającymi na celu przeniesienie tych dyrektyw do prawa krajów członkowskich. Sygnatariusz jest indywidualnie upoważniony do zestawiania dokumentacji technicznej.

## **[RO] DECLARAȚIE DE CONFORMITATE CE**

Subsemnatii adevăresc prin prezenta că vehiculul de specificat mașină descris individual corespunde directivelor europene 2006/42/CE (Directiva privind mașinile) și 2014/30/EU (Compatibilitatea electromagnetică - CEM) inclusiv modificărilor lor precum și actului legislativ corespunzător pentru transpunerea directivelor în drept național. Subsemnatii sunt fiecare în parte împuterniciți să întocmească documentația tehnică.

## **[RUS] Декларация соответствия стандартам ЕС**

Настоящим лица, подписавшие документ, удостоверяют, что машина с указанной спецификацией соответствует европейским стандартам 2006/42/EG (Транспортная директива) и 2014/30/EU (Электromагнитная совместимость - EMC), включая изменения в них, а также соответствующим национальным стандартам и нормам. Каждое по отдельности лицо, подписавшее документ, имеет полномочия для составления технической документации.

## **[S] EG-KONFORMITETSFÖRKLARING**

Underteckarna intygar härmed att det i detalj betecknade maskin uppfyller de Europeiska direktiven 2006/42/EG (Maskindirektiv) och 2014/30/EU (Elektromagnetisk tålighet - EMV), inklusive ändringarna i detta och den motsvarande rättsförfordningen för att omsätta direktiven i nationell rätt.

Underteckarna har var för sig fullmakt att sammanställa den tekniska dokumentationen.

## **[SK] vyhlásenie o zhode**

Dolu podpísaní týmto potvrdzujeme, že podrobný popis uvedené stroje zodpovedá Európskym smerniciam 2006/42/EC (ernica pre stroje) a 2014/30/EU (elektromagnetická tolerancia – EMV) vrátane jeho neskorších úprav, rovnako zodpovedá aj príslušným právnym nariadeniam na uplatnenie smerníc v rámci národného práva. Každý z podpísaných je jednotlivo splnomocnený na vytvorenie technických podkladov.

## **[SLO] EU IZJAVA O SKLADNOSTI**

Podpisani s tem potrjujemo, da posamično označeno določeno stroj vozilo odgovarja Evropski direktivi 2006/42/EC (Direktiva o strojih) in 2014/30/EU (Elektromagnetna skladnost - EMV) vključno z njihovimi spremembami ter ustrezno pravno uredbo o prevzemu smernic v nacionalno pravo. Podpisniki so vsakokrat posamezno pooblašteni za izdajanje tehnične dokumentacije.

## **[TR] AB Uygunluk Açıklaması**

İmza sahibi şahıslar, ayrıntıları belirtilen makine aracının, 2006/42/EC (Makine Yönergesi) ve 2014/30/EU (Elektromanyetik Uyumluluk – EMC) no'lu Avrupa Yönergelerine ve bunların değişiklik sonucu oluşan metinlerine ve yönergelerin milli hukuk hükümlerine dönüştürülmesine dair ilgili hukuk karamamesine uygun olduğunu tasdik ederler. İmza sahibi şahıslar teknik dosyaları bir araya getirmek için münferiden vekil tayin edildi.

- (1) Type/ Typ/ Tipo/ Modello/ Тууппи/ Tipo / ΤΥΠΟΣ/ Tipus/ Tip/ Тип/ Tips/ Tipas/ Tüüp:
- (2) Serial No./ Serien-Nr./ N°. de série/ Serienummer/ N° de serie/ Numero di serie/ Serienr./ Sarjanro/ αριθμός αριθμός/ Seriové číslo/ Szériaszám/ Nr. Seryjny/ Serijska številka/ Výrobné číslo/ Серийный номер/ Seri No./ Seerianr./ Sērijas Nr./ Serijos numeris:
- (3) Year of constr./ Baujahr/ Année de constr./ Bouwjaar/ Año de constr./ Anno di costruzione/ Produktionsår/ Byggeår/ Tillverkningsår/ Valmistusvuosi / Ano de fabrico / έτος κατασκευής/ Rok výroby/ Gyártási év/ Rokprodukcji / Letnik / Год изготовления / Üretim yılı / Väljålaskeasta / Izgatavošanas gads / Gamybosmetai
- (4) Manufacturer or his authorized representative in Community/ Hersteller oder in der Gemeinschaft ansässiger Vertreter/ Fabricant ou son mandataire établi dans la Communauté/ Fabrikant of zijn in de Gemeenschap gevestigde gemachtigde/ Fabricante o representante establecido en la Comunidad/ Construtor ou Representante estabelecido na Comunidade/ Costruttore oppure il suo rappresentante nella Comunità/ Fabrikant eller dennesi Fællesskabet etablerede befuldmægtigede/ Produsent eller agent innen felleskapet/ Tillverkare eller representant inom EU/ Valmistaja tai yhteisömaassa oleva edustaja / V'robce nebo jeho zastoupení/ Gyártó / producent albo jego przedstawiciel w EG (Wspólnota Europejska)/ Κατασκευαστής ή ό κνηνο ηνπηθώλ αληηπηζώπολ/ Üretici ya da Bölgedeki Yetkili Temsilci/ Proizvajalec ali pooblašteni zastopnik s sedežem v EU/ Výrobca alebo zástupca so stálym bydliskom v EÚ / Изготовитель или его представитель, зарегистрированный в стране Содружества/ Tootaja või organisatsioonis paiknevat esindaja/ Ražotājs vai vietējais uzņēmuma pārstāvis / Gamintojas arba šalyje reziduojantis atstovas:
- (5) Date/ Datum/ Data/ Fecha/ datum/ Dato/ päiväys/ Kuupäev/ Datums/ дата / Datum/ dátum/ tarih/ ημερομηνία
- (6) Authorised signatory/ Im Auftrag/ pour ordre/ Incaricato/ Por orden de/ por procuração/ op last van/ på vegne af/ på uppdrag/ Etter oppdrag/ psta./ Ülesandel / pavedus / v.i. / По поручению / megbízásából / длъжностно лице / z pověření / z poverenia / po nalogu / na polecenie / din sarcina / adina / θαη' εληνηή

- sample*  
*If you can read this text, your declaration is not complete. In this case please ask for a copy*
- (1) Type: **XX XX – Self-propelled industrial truck**
  - (2) Serial No.: **XXXXXXXX**
  - (3) Year of constr.: **YYYY**
  - (4) Manufacturer or his authorized representative in Community:  
**Company name/ Street / Postal code Town/ Country**
  - (5) Date: **YYMMDD**
  - (6) Authorized signatory: **Mr. Sample**