

INSTRUCTION HANDBOOK

Electric Pallet Truck

PTE12N

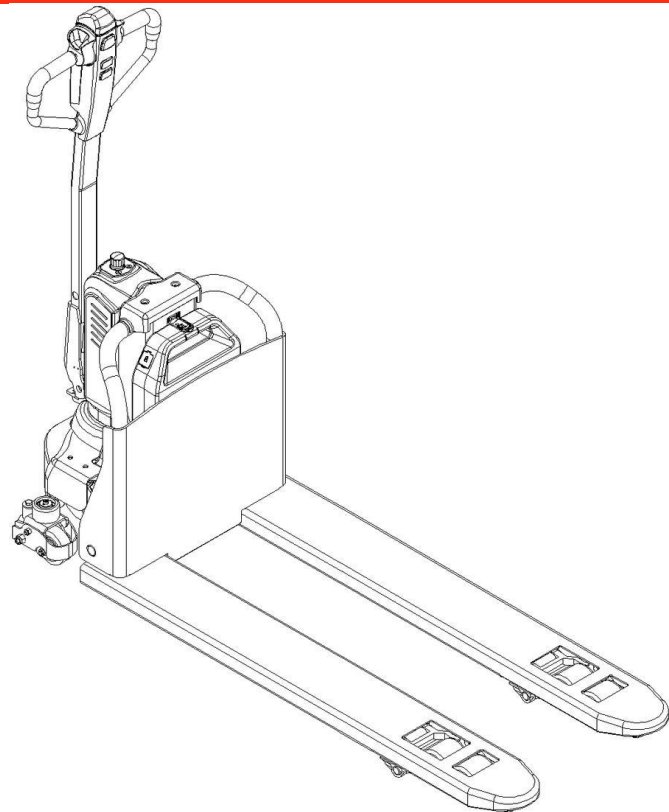

WARNING

Do not use the pallet truck before reading and understanding these operating instructions.

NOTE:

- **Please check the designation of your present type at the last page of this document as well as on the ID-plate.**
- **Keep for future reference.**

Version 07/2019

PTE12N-SMS-001-EN

FOREWORD

Before operating the truck, read this ORIGINAL INSTRUCTION HANDBOOK carefully and understand the usage of the truck completely. Improper operation could create danger.

This handbook describes the usage of different electric pallet trucks. When operating and servicing the truck, make sure, that it applies to your type.

Keep this handbook for future reference. If this or the warning/ caution labels are damaged or got lost, please contact your local dealer for replacement.

This truck complies with the requirements according to EN 3691-1; -5 (Industrial trucks- safety requirements and verification, part 1; part 5), EN 12895 (Industrial trucks- electromagnetic compatibility), EN 12053 (Safety of industrial trucks- test methods for measuring noise emissions), EN 1175-1 (Industrial truck safety – electrical requirements), assumed the truck is used according to the described purpose.

The noise level for this machine is 69 dB(A) according to EN 12053.

ATTENTION:

- Environmentally hazardous waste, such as batteries, oil and electronics, will have a negative effect on the environment, or health, if handled incorrectly.
- The waste packages should be sorted and put into solid dustbins according to the materials and be collected disposal by local special environment protection bureau. To avoid pollution, it's forbidden to throw away the wastes randomly.
- To avoid leaking during the use of the products, the user should prepare some absorbable materials (scraps of wooden or dry duster cloth) to absorb the leaking oil in time. To avoid second pollution to the environment, the used absorbable materials should be handed in to special departments in terms of local authorities.
- Our products are subject to ongoing developments. Because this handbook is only for the purpose of operating /servicing the pallet truck, therefore please have understanding, that there is no guarantee out of particular features out of this handbook.



NOTE: On this manual, the left sign means warning and danger, which can lead to death or serious injury if not followed.

Copyright

The copyright remains with the company, mentioned on the CE- certificate at the end of this document or, if sold within the USA, with the company, mentioned on the company sticker.

TABLE OF CONTENTS

1. CORRECT APPLICATION	4
2. DESCRIPTION OF THE PALLET TRUCK.....	5
a. Overview of the main components	5
b. Main technical data	6
c. Description of the safety devices and warning labels (Europe and other, excepting USA)	8
d. Identification plate	9
3. WARNINGS, RESIDUAL RISK AND SAFETY INSTRUCTIONS	9
4. COMMISSIONING, TRANSPORTING, DECOMMISSIONING	10
a. Commissioning	10
b. Lifting/ transportation	10
c. Decommissioning.....	11
5. DAILY INSPECTION.....	11
6. OPERATING INSTRUCTIONS	12
a. Parking	12
b. Lifting.....	13
c. Lowering.....	13
d. Travelling.....	13
e. Steering.....	14
f. Braking	14
g. Malfunctions.....	14
h. Emergency	14
7. BATTERY CHARGING AND REPLACEMENT	15
a. Replacement.....	15
b. Battery indicator	16
c. Charging.....	16
8. REGULAR MAINTENANCE	17
a. Maintenance checklist.....	18
b. Lubricating points.....	20
c. Check and refill hydraulic oil	20
d. Checking electrical fuses	21
9. TROUBLE SHOOTING	22
10. WIRING/ CIRCUIT DIAGRAM.....	23
a. Electrical circuit diagram	23
b. Hydraulic circuit.....	27
11. SPECIALIZED STIPULATIONS FOR THE US- AMERICAN MARKET	28
a. Foreword/ Compliance.....	28
b. Description warning labels (only US- market)	29
c. Technical data for US market.....	31
12. DECLARATION OF CONFORMITY (valid, if sold within the EU).....	33

1. CORRECT APPLICATION

It is only allowed to use this electric pallet truck according to this instruction handbook.

The trucks described in this handbook are self propelled electric power pallet trucks. The trucks are designed to lift, lower and transport palletized loads.

A wrong usage can cause human injuries or can damage equipment.

The operator/ the operating company has to ensure the correct usage and has to ensure, that this pallet truck is used only by staff, which is trained and authorized to use this truck.

The pallet truck has to be used on substantially firm, smooth, prepared, level and adequate surfaces. The truck is intended to be used for indoor applications with ambient temperatures between +5°C and +40°C and for various transportation applications without crossing permanent obstacles or potholes. The work on ramps is allowed if ramp is not exceeding the allowed angle. While operating, the load must be placed approximately on the longitudinal centre plane of the truck.

Lifting or transporting people is forbidden.

If used on tail lifts or loading ramps, please ensure that these are used correctly according to the operating instructions.

The capacity is marked on capacity sticker as well on the Identification plate. The operator has to consider the warnings and safety instructions.

Operating lighting must be minimum 50 Lux.

Modification

No modifications or alterations to this pallet truck which may affect, for example, capacity, stability or safety requirements of the truck, shall be made without the prior written approval of the original truck manufacturer, its authorized representative, or a successor thereof. This includes changes affecting, for example braking, steering, visibility and the addition of removable attachments. When the manufacturer or its successor approve a modification or alteration, they shall also make and approve appropriate changes to capacity plate, decals, tags and operation and maintenance handbooks.

Only in the event that the truck manufacturer is no longer in business and there is no successor in the interest to the business, may the user arrange for a modification or alteration to a powered industrial truck, provided, however, that the user:

- a) arranges for the modification or alteration to be designed, tested and implemented by an engineer(s) expert in industrial trucks and their safety,
- b) maintains a permanent record of the design, test(s) and implementation of the modification or alteration,
- c) approves and makes appropriate changes to the capacity plate(s), decals, tags and instruction handbook, and
- d) affixes a permanent and readily visible label to the truck stating the manner in which the truck has been modified or altered, together with the date of the modification or alteration and the name and address of the organization that accomplished those tasks.

By not observing these instructions, the warranty becomes void.

2. DESCRIPTION OF THE PALLET TRUCK

a. Overview of the main components

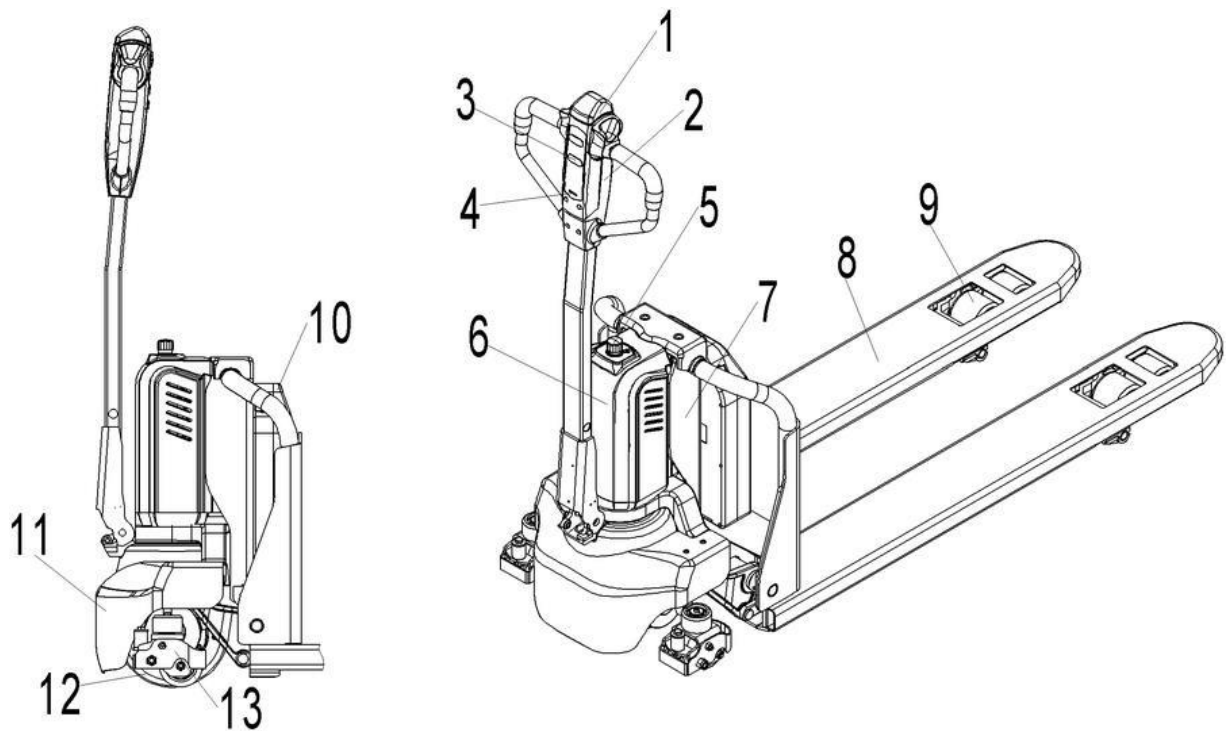

Fig. 1: Overview main components

- | | |
|--|--------------------------|
| 1. Safety (belly) button | 8. Fork |
| 2. Tiller | 9. Load roller |
| 3. Discharge indicator and charging indicating LED | 10. Battery |
| 4. Key switch | 11. Apron |
| 5. Emergency button | 12. Driving unit |
| 6. Hydraulic unit cover | 13. Side roller (option) |
| 7. Chassis | |

b. Main technical data

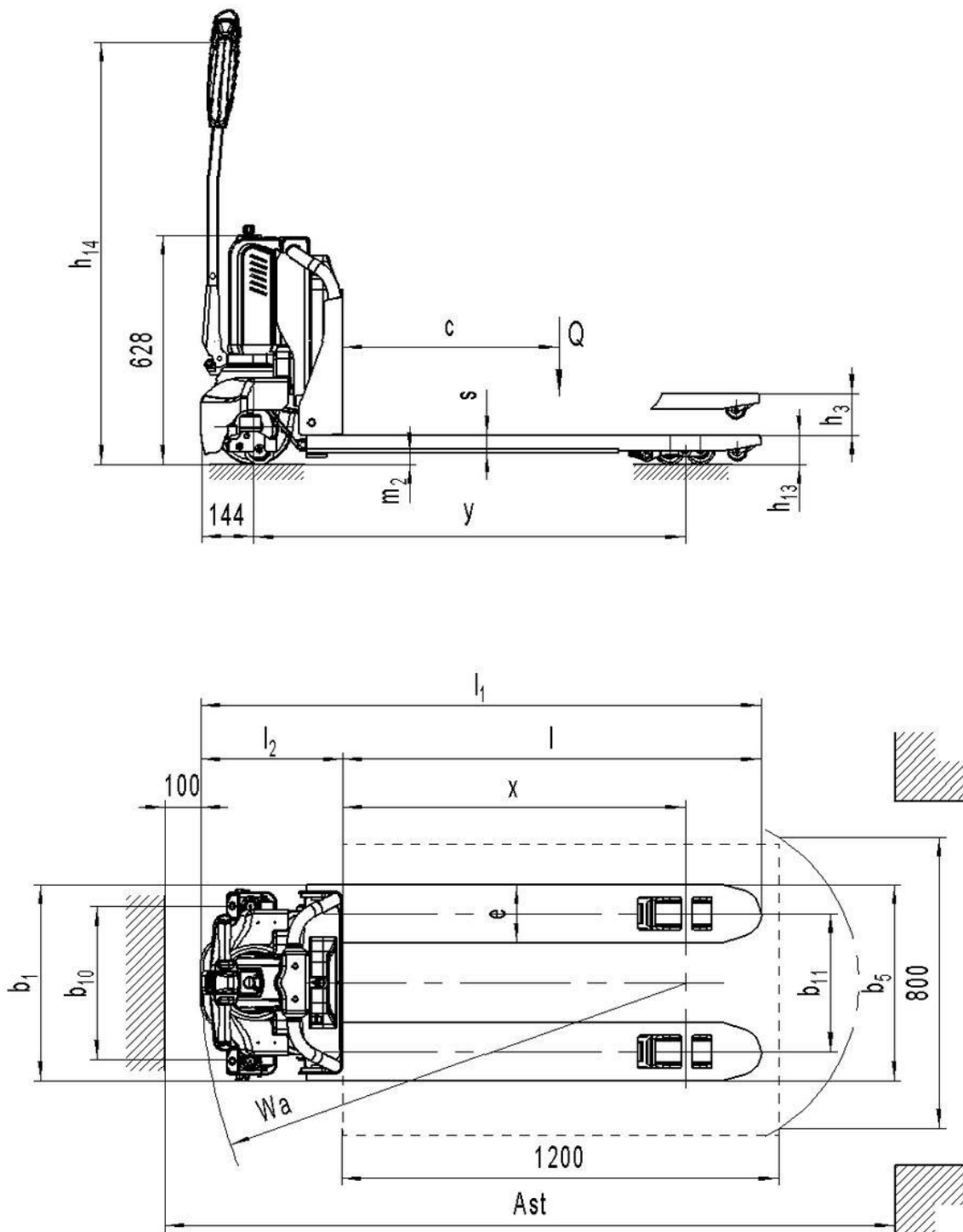

Fig. 2: Technical data

Table 1: Main technical data for standard version

Type sheet for industrial truck acc. to VDI 2198				
Distinguishing mark	1.2	Manufacturer's type designation		PT E12N
	1.3	Drive		Battery
	1.4	Operator type		Pedestrian
	1.5	Load Capacity / rated load	Q (t)	1.2

	1.6	Load centre distance	c (mm)	600	
	1.8	Load distance ,centre of drive axle to fork	x (mm)	942	
	1.9	Wheelbase	y (mm)	1185	
Weight	2.1	Service weight	kg	124	129
	2.2	Axle loading, laden front/rear	kg	355 / 972	425 / 908
	2.3	Axle loading, unladen front/rear	kg	101 / 27	106 / 27
Tyres, chassis	3.1	Tires		Polyurethane (PU)	
	3.2	Tire size,front	∅ x w (mm)	∅ 210x70	
	3.3	Tire size,rear	∅ x w (mm)	∅ 80x93(∅ 80x70)	
	3.4	Additional wheels(dimensions)	∅ x w (mm)	-∅ 80x30	
	3.5	Wheels,number front/rear(x=driven wheels)		1x/ 2(1x/ 4) or 1x +2/ 2(1x +2/ 4)	
	3.6	Tread, front	b ₁₀ (mm)	-/420	
	3.7	Tread, rear	b ₁₁ (mm)	380	525
Dimensions	4.4	Lift	h ₃ (mm)	115	
	4.9	Height of tiller in drive position min./ max.	h ₁₄ (mm)	700 / 1160	
	4.15	Height, lowered	h ₁₃ (mm)	80	
	4.19	Overall length	l ₁ (mm)	1537	
	4.20	Length to face of forks	l ₂ (mm)	387	
	4.21	Overall width	b ₁ (mm)	540	685
	4.22	Fork dimensions	s/e/l (mm)	48 / 160 / 1150	
	4.25	Width across forks	b ₅ (mm)	540	685
	4.32	Ground clearance, centre of wheelbase	m ₂ (mm)	32	
	4.34	Aisle width for pallets800X1200 lengthways (200mm safe distance)	Ast (mm)	2007	
	4.35	Turning radius	Wa (mm)	1337	
Performance data	5.1	Travel speed, laden/ unladen	km/h	4.6 / 4.8	
	5.2	Lift speed, laden/ unladen	m/s	0.031 / 0.037	
	5.3	Lowering speed, laden/ unladen	m/s	0.069 / 0.051	
	5.8	Max. gradeability, laden/ unladen	%	4 / 16	
	5.10	Service brake		Electromagnetic	
Electric- engine	6.1	Drive motor rating S2 60min	kW	0.65	
	6.2	Lift motor rating at S3 10%	kW	0.50	
	6.3	Battery acc. to DIN 43531/ 35/ 36 A, B, C, no		No	
	6.4	Battery voltage, nominal capacity K5	V / Ah	24 / 15	
	6.5	Battery weight	kg	4.4	
	6.6	Energy consumption acc. to VDI cycle	kWh/h	0.14	
Addition data	8.1	Type of drive control		DC speed Control	
	8.4	Sound level at driver's ear acc. to EN 12053	dB(A)	<70	

c. Description of the safety devices and warning labels (Europe and other, excepting USA)



For the USA –market, the description of the safety and warning labels is mentioned in chapter 11.

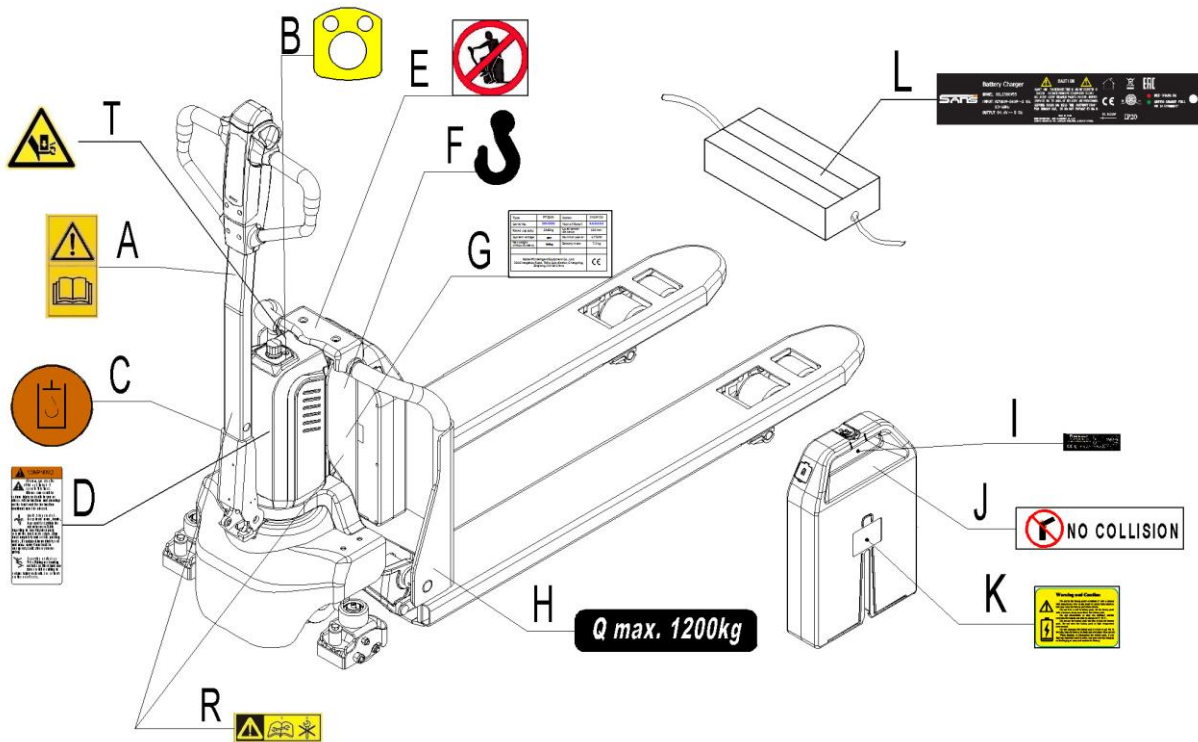

Fig. 3: Safety and warning labels

- | | | | |
|---|---|---|---|
| A | Sticker to read and follow this instruction | H | Capacity sticker |
| B | Emergency button sticker | I | Battery ID plate |
| C | Sign oil filling point | J | No collision sticker |
| D | Warning sticker | K | Battery warning sticker |
| E | “No passengers” decal | L | Charger ID plate |
| F | Crane hook label | R | Sticker to read and follow service manual |
| G | Identification plate (ID-plate) | T | Warning sticker |

The truck is equipped with an emergency switch (5) which stops all lifting-, lowering-, driving- functions and engages the failsafe electromagnetic brake when it is pressed. By turn this button clockwise, the truck can be operated after the controller checked the functions. Before operating, insert the key. To prevent against unauthorized access, press emergency switch (5) or remove key (4).

The truck is equipped with a safety (belly) button (1) which switches the driving function away from the operator, if the truck travels towards the operator and the tiller is activated in the tillers operating zone. Follow also the instructions given on the decals. Replace the decals if they are damaged or missing.

d. Identification plate

- | | | | |
|---|--|----|---------------------------------|
| 1 | Designation, type | 7 | Battery weight minimum/ maximum |
| 2 | Serial number | 8 | Nominal power in kW |
| 3 | Rated capacity in kg | 9 | Load center distance |
| 4 | Supply voltage in V | 10 | Manufacturing date |
| 5 | Own mass (self weight) in kg without battery | 11 | Option |
| 6 | Name and address of manufacturer) | | |

1	Type	xxx xx	Option	xx X xxxx	11
2	Serial No.	xxxxx	Year of Manuf.	MM/YYYY	10
3	Rated capacity	xxxx kg	Load center distance	xxx mm	9
4	System voltage	xx V	Nominal power	xx kW	8
5	Net weight without battery	xxx kg	Battery mass min/max	xxx / xxx kg	7
6	XXXX XXXX XXXXXXXXXX xx XXXXX / XXXXXX			CE	

If sold to the EU, here the place of the CE marking **CE**

Fig. 4: Identification plate

3. WARNINGS, RESIDUAL RISK AND SAFETY INSTRUCTIONS



DO NOT

- Put foot or hand under or into the lifting mechanism.
- Allow other person than the operator to stand in front of or behind the truck when it is moving or lifting/lowering.
- Overload the truck.
- Put foot in front of the wheels, injury could result.
- Lift people. People could fall down and suffer severe injury.
- Push or pull loads
- Side or end load. Load must be distributed evenly on the forks.
- Use the truck with unstable, unbalanced not stable load.
- Use truck without manufacturer's written consent.
- Lifted loads could become unstable at wind forces. In the case of wind forces do not lift the load if there is any influence to the stability

Watch difference in floor levels when driving. Load could fall down or the truck could get uncontrollable.

Keep watching the condition of load. Stop operating the truck if load becomes unstable.

Brake the truck and activate the emergency button (5) by pushing when sliding load on or off the truck. If the truck has any malfunctions, follow chapter 9.

Practice maintenance work according to regular inspection. This truck is not designed to be water resistant. Use the truck under dry condition. Prolonged continuous operation might cause damage of the power pack. Stop operation if temperature of hydraulic oil is too high.



- When operating the electric pallet truck, the operator has to wear safety shoes.
- The truck is intended to be used for indoor applications with ambient temperatures between +5°C and + 40°C.
- The operating lighting must be minimum 50 Lux.
- To prevent unintended sudden movements when not operating the truck (i.e. from another person, etc.), press emergency switch (5) or remove the key (4).

4. COMMISSIONING, TRANSPORTING, DECOMMISSIONING

a. Commissioning

Table 2: Commissioning data

Type	PTE12N (540X1150)	PTE12N (685X1150)
Commissioning weight [kg]	124kg	129kg
Dimensions [mm]	1530x540x1250	1530x685x1250

After receiving our new pallet truck or for re-commissioning you have to do following before (firstly) operating the truck:

- Check if are all parts included and not damaged
- Make sure the tiller is assembled correctly (electrical socket is connected and fixed with two plastic clamps, circlip of the axle is installed)
- Check that battery is charged (follow chapter 7)
- Do the work according to the daily inspections as well as functional checks.

b. Lifting/ transportation

For transporting, remove the load, lower the forks to the lowest position and fix the truck safe with dedicated lifting gear according to the following figures.

Lifting

USE DEDICATED CRANE AND LIFTING EQUIPMENT

DO NOT STAND UNDER THE SWAYING LOAD

DO NOT WALK INTO THE HAZARDOUS AREA DURING LIFTING

Park the truck securely and lash the truck according to the points identified in Fig. 5. Lift the truck to its destination and place the truck securely before removing the lifting gear. The lashing points are according to the Fig. 5.

Transportation



DURING TRANSPORTATION ON A LORRY OR TRUCK ALWAYS FASTEN THE TRUCK SECURELY

Lower the forks and park the truck securely.

Fasten the truck according to Fig. 6 by fixing dedicated lashing belts to each side of the trucks crane hook holes and fasten the other side at the transporting truck.

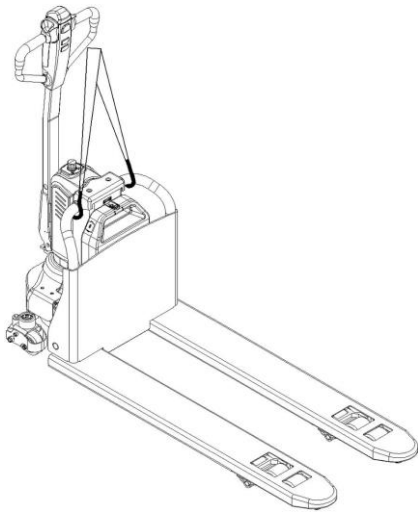

Fig. 5: Lifting with a crane

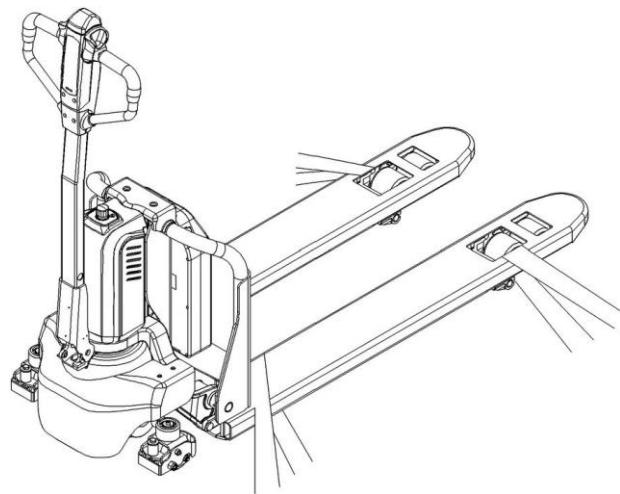

Fig. 6: fixing points

c. Decommissioning

For storage, remove the load, lower the truck to the lowest position, grease all in this handbook mentioned greasing points (regular inspection), and eventually protect the truck against corrosion and dust. Remove the batteries and jack the truck safely, so that there will be no flattening after storage.

For final decommissioning hand the truck to a designated recycling company. Oil, batteries and electric components must be recycled due to legal regulations.

5. DAILY INSPECTION

This chapter describes pre-shift checks before putting the truck into operation.

Daily inspection is effective to find the malfunction or fault on this truck. Check the truck on the following points before operation.

Remove load from truck and lower the forks.



DO NOT USE THE TRUCK IF ANY MALFUNCTION IS FOUND.

- Check for scratches, deformation or cracks.
- Check if there is any oil leakage from the cylinder.

- Check the smooth movement of the wheels.
- Check the function of driving in both directions (section 6d).
- Check the functions of braking by activation of tiller arm sensor, reversing of driving buttons, release of driving buttons and of the safety (belly) button (section 6f).
- Check the function of driving with tiller in its vertical position (section 6d).
- Check the function of the emergency brake by activating the emergency button.
- Check the lifting and lowering functions by operating the buttons (section 6b and 6c).
- Check the function of steering by turning the tiller from one end position to the other one. The steering should be smooth, without jerks or abnormal sound.
- Check if all bolts and nuts are tightened firmly.
- Visual check if there are any broken electric wires.
- If supplied with a backrest extension, check it for damages and correct assembling.
- Check the presence of warning stickers and signs (section 2c and section 11)

6. OPERATING INSTRUCTIONS



BEFORE OPERATING THIS TRUCK, PLEASE FOLLOW THE WARNINGS AND SAFETY INSTRUCTIONS (CHAPTER 3).

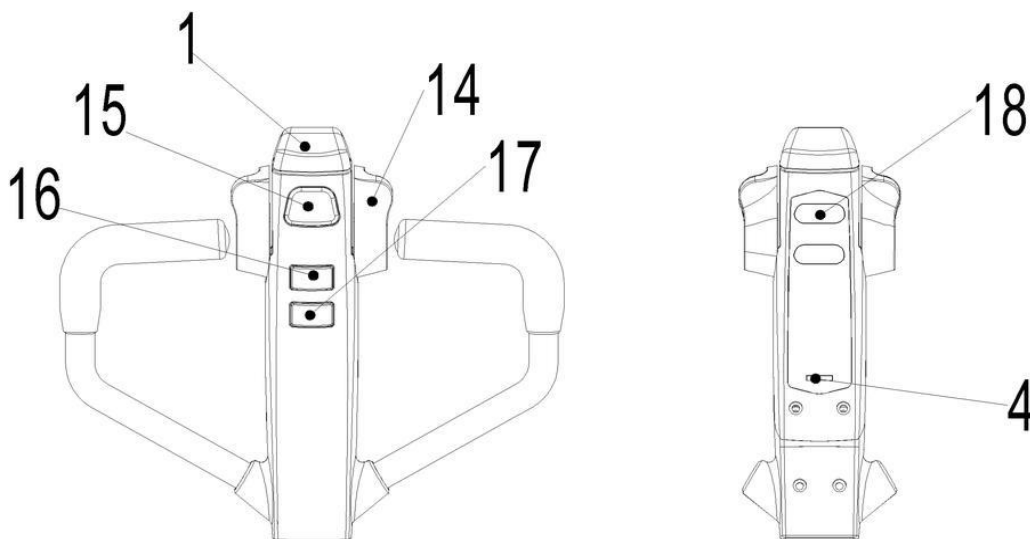

Fig.7: Tiller operating controls

Make sure, that the load is palletized and stable and that the daily inspection is carried out.

Turn emergency button (Fig.1, 5) clockwise, and insert the key (Fig.1, 4).

Press the horn button (Fig.7, 15) to activate the audible warning signal.

a. Parking



DO NOT PARK THE TRUCK ON INCLINED SURFACES

The truck is equipped with an electromagnetic failsafe stopping and parking brake.

Always lower the forks fully. Press the emergency switch (5).

b. Lifting



DO NOT OVERLOAD THE TRUCK!
THE MAXIMUM CAPACITY OF PTE12N IS 1200 kg.

Travel with the lowered forks fully underneath the pallet and press the lifting button (Fig. 7, 16) until you reached the desired lifting height.

c. Lowering

Press the lowering button (17) carefully.
Lower the load until the forks are clear of the pallet, then drive the truck carefully out of the load unit.

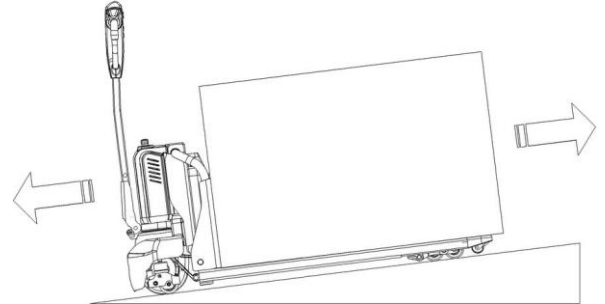

Fig. 8: Load facing uphill

d. Travelling



TRAVEL ON INCLINES ONLY WITH THE LOAD FACING UPHILL.
DO NOT TRAVEL ON INCLINES MORE THAN SPECIFIED WITH THE TECHNICAL DATA.

After starting the truck by inserting the key, move the tiller to the operating zone ('F', Fig.9).
Turn the accelerator button to the desired direction forward 'Fw.' or backwards 'Bw.'(Fig. 9).

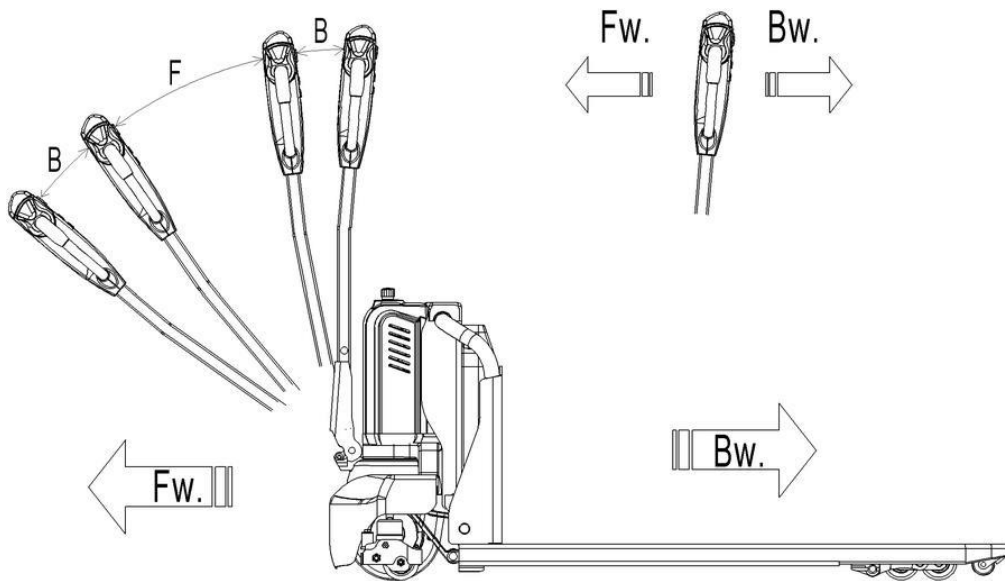

Fig. 9: Operating direction

Control the travelling speed by moving the accelerator button (Fig.7,14) carefully until you reached the desired speed. If you move the accelerator button back to the neutral position, the controller decelerates the truck until the truck stops. If the truck stopped, the parking brake will be engaged.

Drive carefully the truck to the destination. Watch the route conditions and adjust the travelling speed with the accelerator-button.

Press turtle button (Fig.7, 18) to enter into slow speed mode, travel slowly by moving the accelerator

button (Fig.7,14) , press turtle button again to return back to regular mode.

Press turtle button and hold for 2 seconds to activate driving function with tiller in its vertical position when operating in confined areas. The driving function is active only when turtle button is pressed (the speed is reduced); the release of turtle button will cause immediate stop. The activation of accelerator button in time gap shorter than two seconds after the turtle button is pressed will not activate the driving function, the activation cycle has to be repeated from the beginning. Accelerator button should remain in neutral position till two seconds passed.

e. Steering

You steer the truck by moving the tiller to the left or right side.

f. Braking



PLEASE CHECK THE BRAKING DISTANCE WITH TRUCK BEFORE OPERATION
THE BRAKING PERFORMANCE DEPENDS ON THE TRACK CONDITIONS AND
THE LOAD CONDITIONS OF THE TRUCK

The braking function can be activated on several ways:

- By moving the accelerator button (14) back to the initial '0' position or by releasing the button, the regenerative braking is activated. The truck brakes until it stops.
- By moving the accelerator button (14) from one driving direction directly to the opposite direction, the truck brakes regenerative until it starts traveling into the opposite direction.
- The truck brakes, if the tiller is moved up or down to the braking zones ('B'). If the tiller is released, the tiller moves automatically up to the upper braking zone ('B').The truck brakes until it stops.
- The safety (belly) button (1) prevents the operator from being crushed. If this button is activated, the truck decelerates and/ or starts traveling into the backwards direction ('Bw.')

g. Malfunctions

If there are any malfunctions or the truck is inoperative, please stop using the truck and activate the emergency button (5) by pushing it. If possible, park the truck on a safe area and remove the key (4). Inform immediately the manager and, or call your service. If necessary, tow the truck out of the operating area by using dedicated towing/ lifting equipment.

h. Emergency

In emergencies or in the event of tip over (or off dock), keep safe distance immediately. If possible push the emergency button (5). All electrical functions will be stopped.

7. BATTERY CHARGING AND REPLACEMENT



- Only qualified personnel are allowed to service or charge the batteries. The instructions of this handbook must be observed.
- The batteries are lithium batteries.
- Recycling of batteries undergoes national regulations. Please follow these regulations.
- By handling batteries, open fire is prohibited!
- In the area of battery charging neither burning materials nor burning liquids are allowed. Smoking is prohibited and the area must be ventilated.
- Park the truck securely before starting charging or installing/changing the batteries
- Before finishing the maintenance work, make sure, that all cables are connected correctly and that there are no disturbing towards other components of the truck.

Table 3: Available batteries

Model	Battery
PTE12N	24V15Ah lithium battery, 4.4kg



IT IS ONLY ALLOWED TO USE LITHIUM BATTERIES.
PLEASE CONSIDER THE MAXIMUM OPERATING TEMPERATURE OF THE BATTERIES.

a. Replacement

Park the truck securely and press emergency switch (5). Hold the battery grip with one finger pull out the lock, and then take out the battery vertically. The installation is in the reverse order.

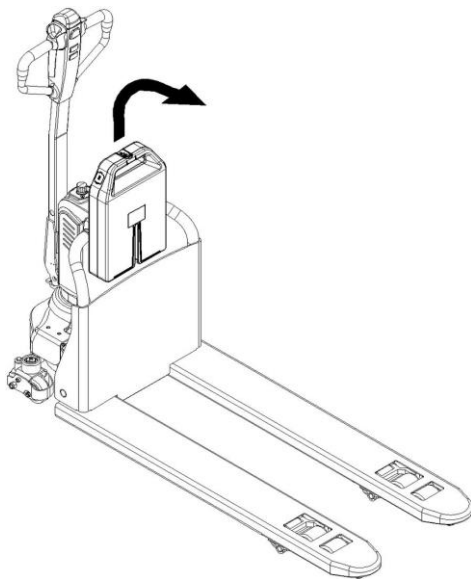

Fig. 10: Battery replacement

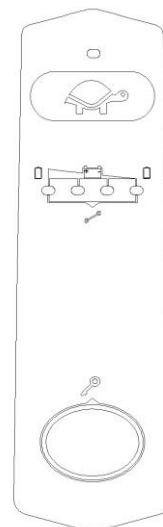

Fig. 11: Battery discharge indicator

b. Battery indicator

Turtle Symbol:



It is normally off, when it appears (fixed) it shows activation of the “soft” mode of the truck, in which maximum speed and acceleration are reduced.

Battery State of charge

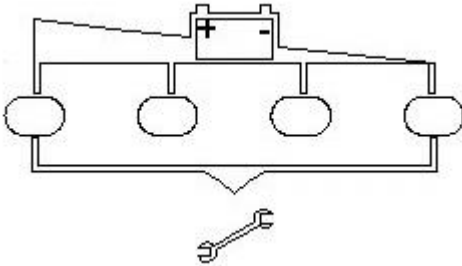

Battery's state-of-charge is indicated by four LED on the tiller:

The 1st green LED from left is on, indicating 75% -100% of battery power.

The 2nd blue LED from left is on, indicating 50% -75% of battery power.

The 3rd yellow LED from left is on, indicating 25% -50% of battery power.

The 4th LED from left is on, indicating 0% -25% of battery power.

If there is fault code, four LEDs will flash for 1s, then the 1st green LED from left will flash and count, after that the 4th LED from left will flash and count. The amount that green LED flashes times ten, then plus the amount that led LED flashes means the fault code.

c. Charging



- Before charging ensure that you are using an appropriate charger for charging the installed battery.
- Before using the charger, please fully understand the instructions of the charger instructions.
- Always follow these instructions.
- The room, where you are charging must be ventilated.
- The exactly charge status can be only checked from the discharge indicator. To control the status, the charging must be interrupted and the truck must be started.

Park the truck at a dedicated secured area with a dedicated power supply.

Lower the forks and remove the load;

Switch the truck off and connect the charger plug (20) to the charging port (21) on the battery. The charger starts charging the battery if the charger plug (19) is connected to the main power supply.

Disconnect the charger plug from the battery and close the cap after the charger finished charging.

When charging is finished, disconnect the plug (19) from the socket and place it in the designated pocket.

It's also allowed to remove the battery out and charge in dedicated area.

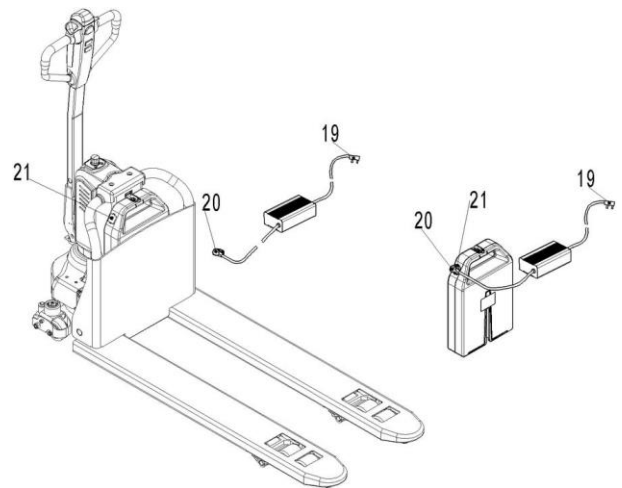

Fig.12: Battery charging

Table 4: LED-Status

LED- signal	Function
Red	Charging
Green	Fully charged

Table 5: Charger PTE12N

Model	Specification	Input	Output
DZL2420SS02	24V5A (Chinese sticker)	180Vac -240Vac~2.0A MAX	29.4V 5.0A
DZL2420SS02	24V5A (English sticker)	180Vac -240Vac~2.0A MAX	29.4V 5.0A
S12030-C0500	24V5A (US)	100Vac -240Vac~3.5A MAX	29.4V 5.0A
SSLC165V29	24V5A (EU)	180Vac -240Vac~3.0A MAX	29.4V 5.0A

8. REGULAR MAINTENANCE



- Only qualified and trained personnel are allowed to do maintenance on this truck.
- Before maintaining, remove the load from the forks and lower the forks to the lowest position.
- If you need to lift the truck, follow chapter 4b by using designated lashing or jacking equipment. Before working, put safety devices (for instance designated lift jacks, wedges or wooden blocks) under the truck to protect against accidental lowering, movement or slipping.
- Please pay attention by maintain the tiller arm. The gas pressure spring is pre-loaded by compression, carelessness can cause injury.
- Use approved and from your dealer released original spare parts.
- Please consider that oil leakage of hydraulic fluid can cause failures and accidents.
- It is allowed to adjust the pressure valve only from trained service technicians.

Check the items emphasized in maintenance checklist.

a. Maintenance checklist

Table 6: Maintenance checklist

		Interval(Month)			
		1	3	6	12
Hydraulic					
1	Check the hydraulic cylinder(s), piston for damage noise and leakage		•		
2	Check the hydraulic joints for damage and leakage		•		
3	Inspect the hydraulic oil level, refill if necessary		•		
4	Refill the hydraulic oil (12 month or 1500 working hours)				•
5	Check and adjust function of the pressure valve (1200kg(PTE12N)+0/+10%)				•
Mechanical system					
6	Inspect the forks for deformation and cracks		•		
7	Check the chassis for deformation and cracks		•		
8	Check if all screws are fixed		•		
9	Check the push rods for deformation and damages		•		
10	Check the gearbox for abnormal sound and noise		•		
11	Inspect the wheels for deformation and damages		•		
12	Inspect and lubricate the steering bearing if necessary				•
13	Inspect and lubricate the pivot points if necessary		•		
14	Lubricate the grease nipples	•			
Electrical system					
15	Inspect the electric wiring for damage		•		
16	Check the electric connections and terminals		•		
17	Test the Emergency switch function		•		
18	Check the electric drive motor for noise and damages		•		
19	Test the display		•		
20	Check, if correct fuses are used		•		
21	Test the warning signal		•		
22	Check the contactor(s)		•		
23	Check the frame leakage (insulation test)		•		
24	Check function and mechanical wear of the accelerator		•		
25	Check the electrical system of the drive motor		•		
Braking system					
26	Check brake performance, if necessary replace the brake disc or adjust the air gap		•		
Battery					
27	Check the battery voltage		•		
28	Clean and grease the terminals and check for corrosion and damage		•		
29	Check the battery housing for damages		•		
Charger					
30	Check the main power cable for damages			•	
31	Check the start-up protection during charging			•	
Function					
32	Check the horn function	•			
33	Check the air gap of the electromagnetic brake	•			

34	Test the emergency braking	•			
35	Test the reverse and regenerative braking	•			
36	Test the safety (belly) button function	•			
37	Check the steering function	•			
38	Check the lifting and lowering function	•			
39	Check the tiller arm switch function	•			
General					
40	Check if all decals are legible and complete	•			
41	Inspect the castors, adjust the height or replace these if worn out.		•		
42	Carry out a test run	•			

b. Lubricating points

Lubricate the marked points according to the maintenance checklist. The required grease specification is: DIN 51825, standard grease.

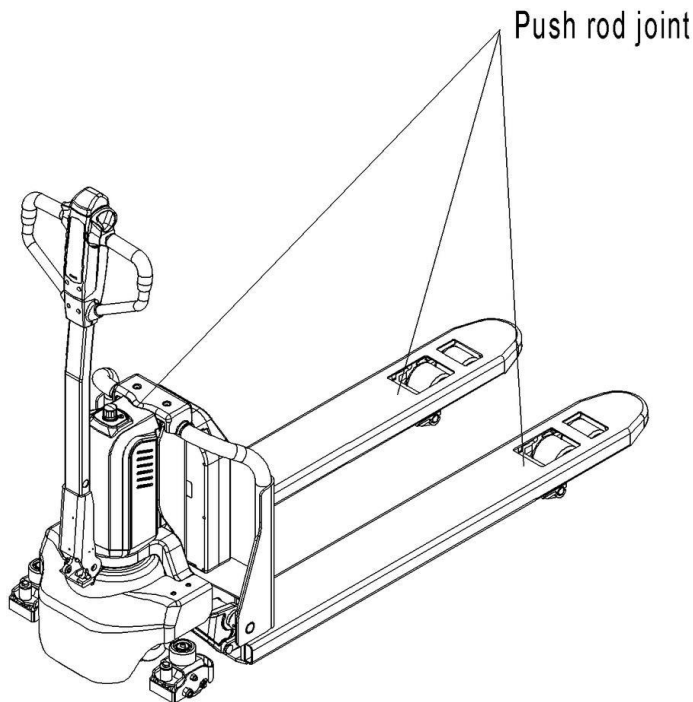

Fig. 13: Lubricating points

c. Check and refill hydraulic oil

It is recommended to use hydraulic oil in connection with average temperature:

Environment temperature	-5°C~25°C	>25°C
Type	HVLP 32, DIN 51524	HLP 46, DIN 51524
Viscosity	28.8-35.2	41.4 - 47
Amount	0.4L	

Waste material like oil, used batteries or other must be probably disposed and recycled according to the national regulations and if necessary brought to a recycling company.

The oil level in the oil tank should be between min and max marks with fully lowered forks.

If necessary add oil at the filling point.

d. Checking electrical fuses

Remove the main cover. The fuses are located according to Fig. 14; the size is according to table 7.

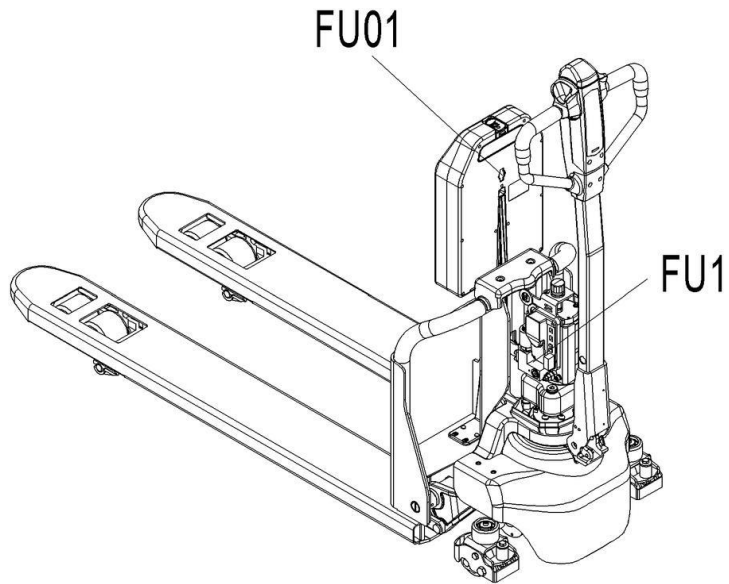

Fig. 14: Location of fuses for PTE12N

Table 7: Size of the fuses

	Rate
FU 1	10A
FU 01	70A

9. TROUBLE SHOOTING



- If the truck has malfunctions follow the instructions, mentioned in chapter 6.

Table 8: Trouble shooting

TROUBLE	CAUSE	REPAIR
Load can't be lifted	Load weight too high	Lift only the max. capacity, mentioned on the ID-plate
	Battery low power	Charge the battery
	Lifting contactor failure	Check and contact with service support for replacement if necessary
	Hydraulic oil level too low	Check and eventually refill hydraulic oil
	Oil leakage	Repair the sealing of the cylinder
Oil leakage from air breathing	Excessive quantity of oil.	Reduce oil quantity.
Truck not starts operating	Battery is charging	Charge the battery completely and then remove the main power plug from the electrical socket.
	Battery not connected	Connect the battery correctly
	Fuse faulty	Check and eventually replace fuses
	Low battery	Charge the battery
	Emergency switch is activated	Turn the emergency clockwise
Tiller in the operating		Move the tiller firstly to the braking zone.

If the truck has malfunctions and can't be operated out of the working zone, jack the truck up and go with a load handler under the truck and safe the truck securely. Then move truck out of the aisle.

10. WIRING/ CIRCUIT DIAGRAM

a. Electrical circuit diagram

PTE12N without speed reduction on curves

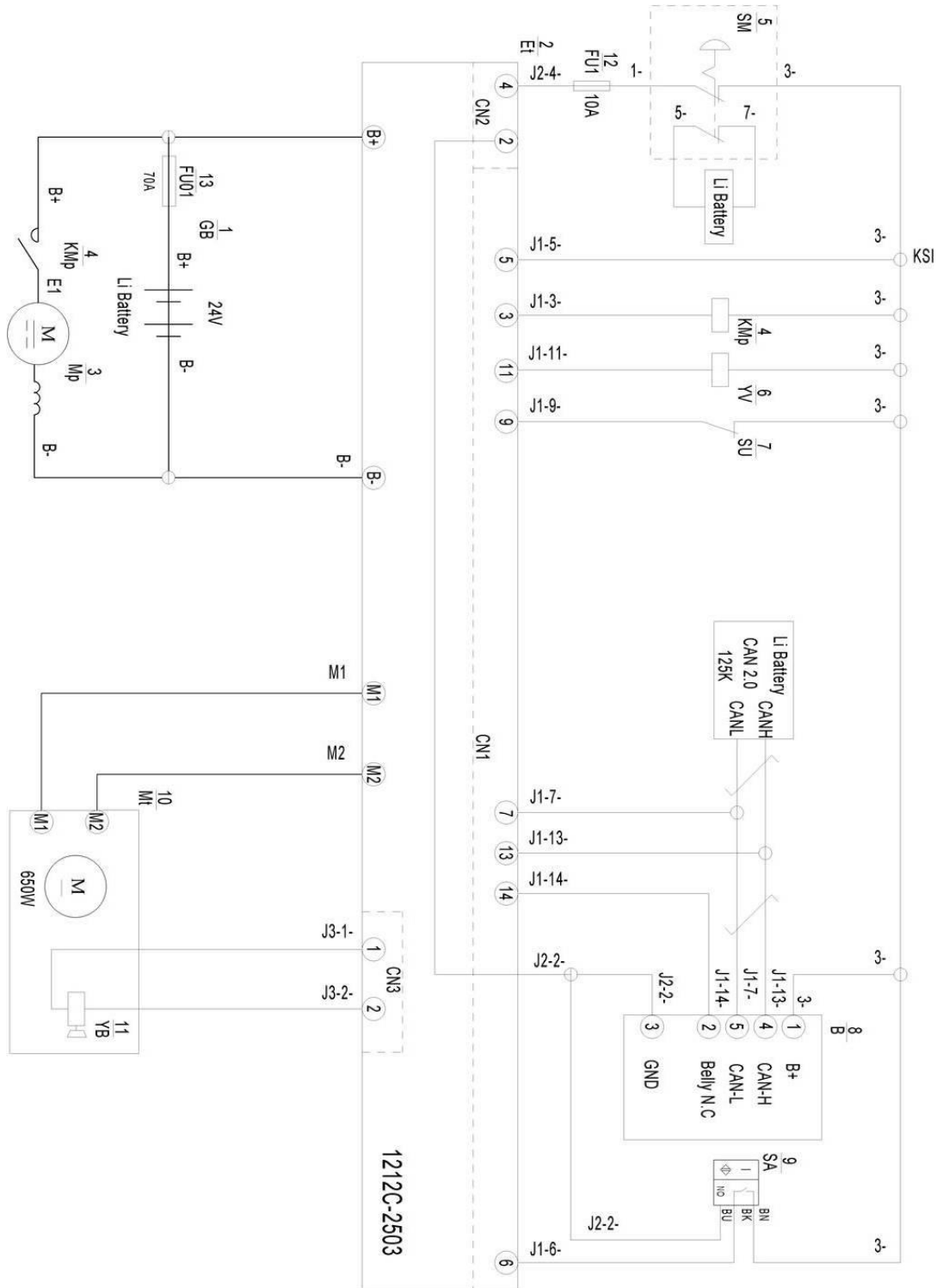

FU 1 : 10A
FU 01 : 70A

Fig.15: Electric diagram

Table 9: Description of electrical diagram

Code	Item	Code	Item
GB	Battery	B	CAN tiller
Et	Controller	SA	Proximity switch
Mp	Pump motor	Mt	Traction motor
KMp	Pump contactor	YB	Electromagnetic brake
SM	Emergency button	FU1	10A fuse
YV	Electromagnetic valve	FU01	70A fuse
SU	Micro switch		

PTE12N with speed reduction on curves

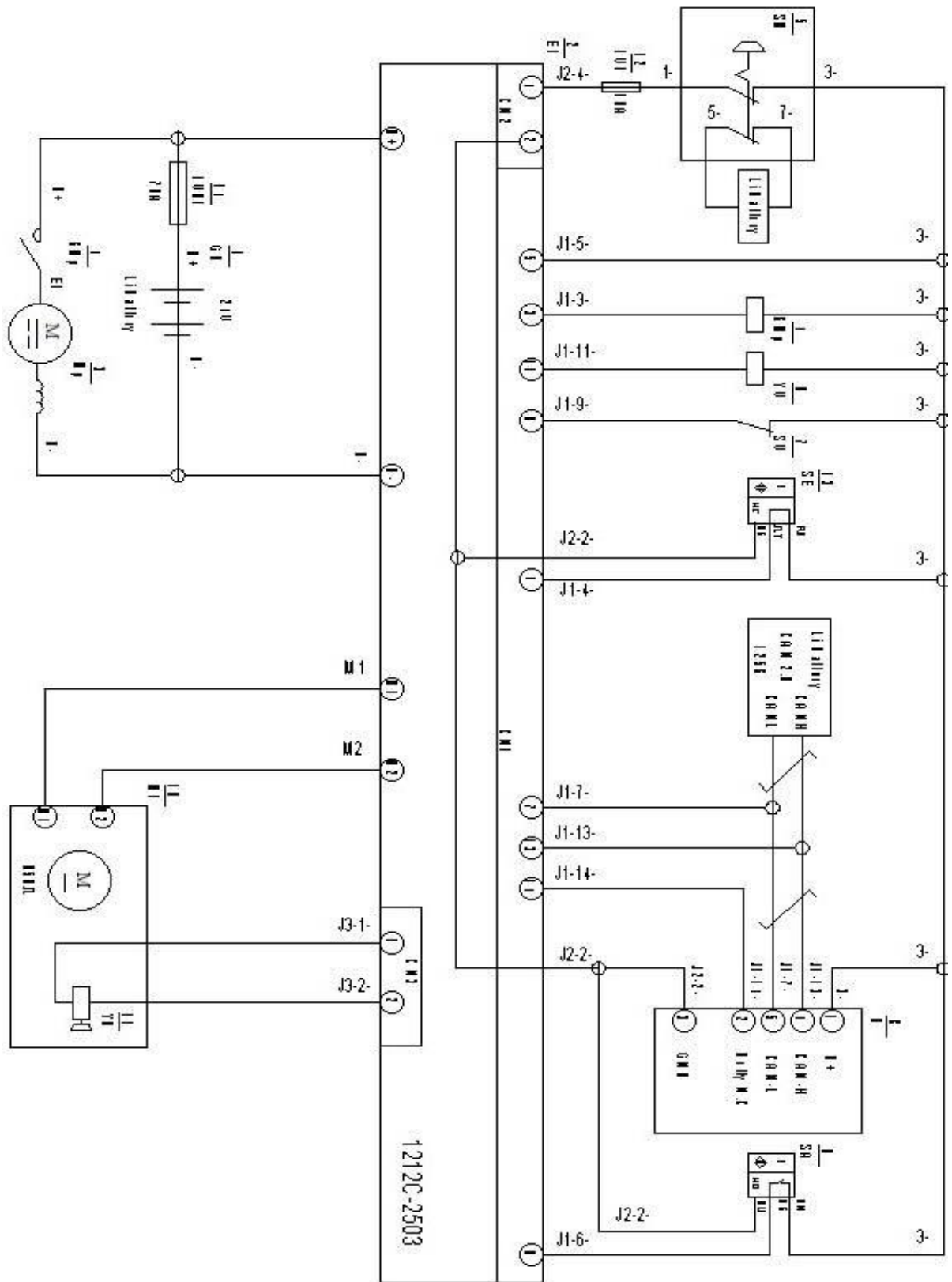

FU1 :10A
FU01 : 70A

Fig.16: Electric diagram

Table 10: Description of electrical diagram

Code	Item	Code	Item
GB	Battery	B	CAN tiller
Et	Controller	SA	Proximity switch
Mp	Pump motor	Mt	Traction motor
KMp	Pump contactor	YB	Electromagnetic brake
SM	Emergency button	FU1	10A fuse
YV	Electromagnetic valve	SE	Proximity switch
SU	Micro switch	FU01	70A fuse

b. Hydraulic circuit

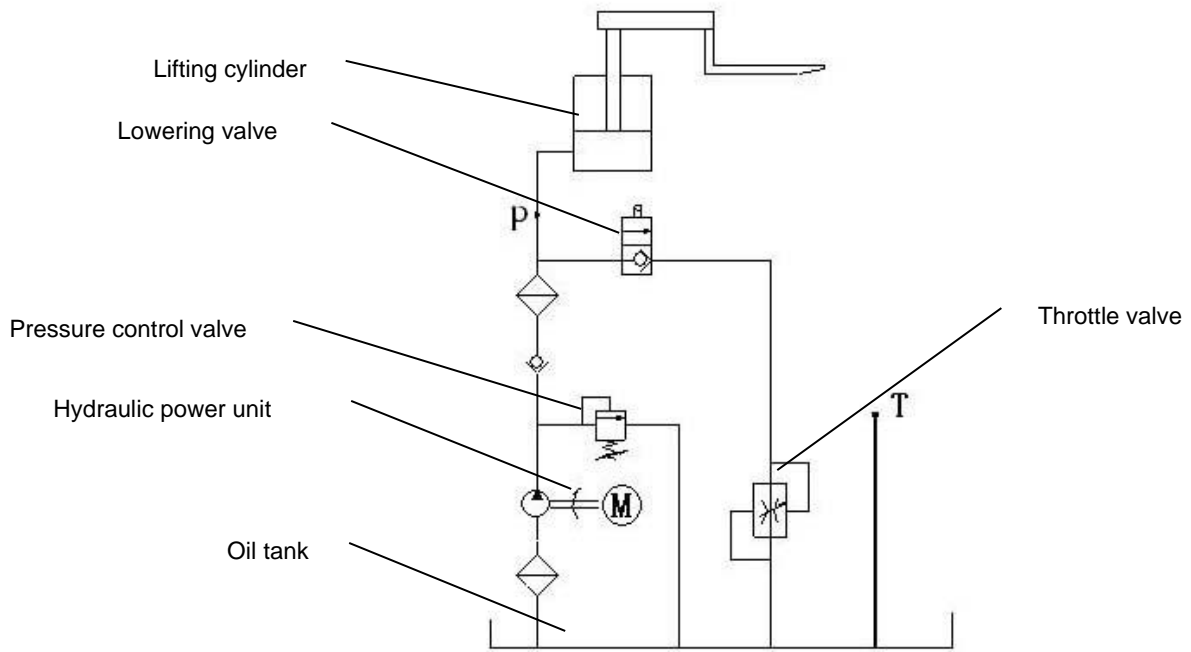

Fig. 17: Hydraulic circuit

11. SPECIALIZED STIPULATIONS FOR THE US- AMERICAN MARKET

The content in this chapter is specialized for the US-American market.

a. Foreword/ Compliance

Operating this truck requires knowledge which can be acquired from this instruction handbook. This handbook must be kept available throughout the entire period of use of the industrial truck.

IT IS LAW; YOU MUST BE TRAINED AND CERTIFIED TO OPERATE THIS TRUCK! READ AND OBEY ALL WARNINGS AND INSTRUCTIONS IN THIS MANUAL AND ON THE TRUCK!

Only properly trained operators are allowed to operate a powered industrial truck. Your employer must train you and certify, that you are qualified to operate this truck (required by OSHA § 1910.178). The training must satisfy OSHA requirements and as minimum the topics mentioned in this handbook. Depending on the context in this operating manual, the user can refer to several people, including the owner of the truck, anyone who leases or borrows this truck, and the operator as defined in ASME B56.1. Please pay attention to the section in ASME B56.1 concerning the operator. In this standard, it is defined that the safe operation is the responsibility of the operator (ASME B56.1-2003, Part II, section 5.1.1). You and others can be seriously injured or even killed if you don't use this truck correctly. Before operating your truck, inspect your truck and ensure that it is in correct working order. This truck was designed and built to current industry and government standards. For more information see following:

- ASME B56.1 (American Society of Mechanical Engineers)
- OSHA §1910.178 (Occupational Safety and Health Act)
- UL 583 (Underwriters Laboratory)
- ANSI Z535.4 (American National Standards Institute)

⚠ DANGER This sign indicates hazard situations, if not avoided, will result in serious injury or death. The instructions or precautions to this message must be observed to avoid the potential risk of injury or death.

⚠ WARNING If not followed, warning indicates hazard situations which may lead to moderate injury. The instructions or precautions to this message must be observed to avoid the potential risk of injury or death.

⚠ CAUTION If not followed, caution indicated situations which may lead to minor injury. Instructions or precautions must be observed to avoid minor injury.

b. Description warning labels (only US- market)

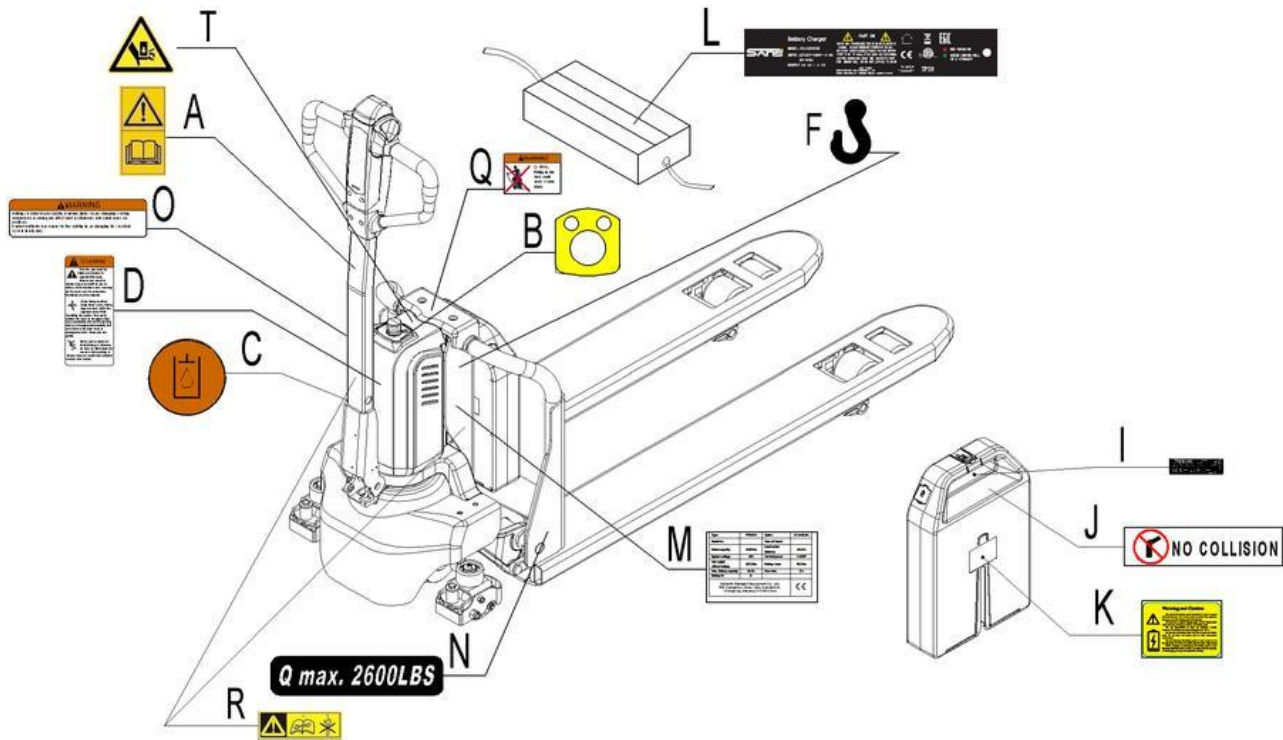

Fig. 18: Warning labels and safety devices (only USA)

- | | | | |
|---|---|---|---|
| A | Sticker to read and follow this instruction | L | Charger ID plate |
| B | Emergency button sticker | M | Name plate |
| C | Sign oil filling point | N | Capacity sticker |
| D | Warning sticker | O | Sign warning electrical device |
| F | Crane hook label | Q | No passenger |
| I | Battery ID plate | R | Sticker to read and follow service manual |
| J | No collision sticker | T | Warning sticker |
| K | Battery warning sticker | | |

The truck is equipped with an emergency button (5) which stops all lifting-, lowering-, driving- functions and engages the failsafe electromagnetic brake when it is pushed. The function is described in chapter 2c. Follow the instructions given on the decals. Replace the decals if they are damaged or missing.

Sign read and follow this instruction (D)



Sign oil filling point (E)



Sign warning stay clear stop truck (J)

WARNING

 **It is law, you must be certified and trained to operate this truck. Misuse can result in serious injury or death to you or others. All instructions and warnings on the truck and the instruction handbook must be obeyed.**

 **Avoid being crushed. Keep head, arms, hands, legs and feet within the operator area. While travelling be careful when parts extend the truck or its edges. Stop truck completely and set the parking brake, if equipped. Immediately exit and move away from truck in emergency. Look where you are going.**

 **Never ride or stand on forks. Riding or standing on forks or lifted load can cause a fall resulting in serious injury or death. Use extreme caution near docks.**

Sign warning electrical devices (K)

WARNING

Adding electrical devices (radio, terminal, lights etc.) or changing existing components or wiring can affect truck performance and could cause an accident. Contact authorized personnel before adding to, or changing the electrical system in any way.

Sign no collision (N)



Sign emergency switch (P)

Warning sticker

Warning and Caution

 Do not let the battery pack's terminals or a contact with electrolyte come in any contact or connect them together that may cause the battery pack short-circuit.

 Do not drive a truck or battery pack, fit the battery pack with a battery, except on or from the battery pack.

Do not disassemble or alter the battery's outside structure. The battery capacity be changed in the ...

Do not put the battery pack into fire or heat the battery pack, do not store the battery pack in high temperature environment.

Do not submerge the battery pack in water or get wet in the rain, keep the battery in clean and cool place when stored.

When charging or discharging the battery pack, if you find any abnormal smell or noise, you must stop the charging or discharging at once, and contact the battery.

c. Technical data for US market

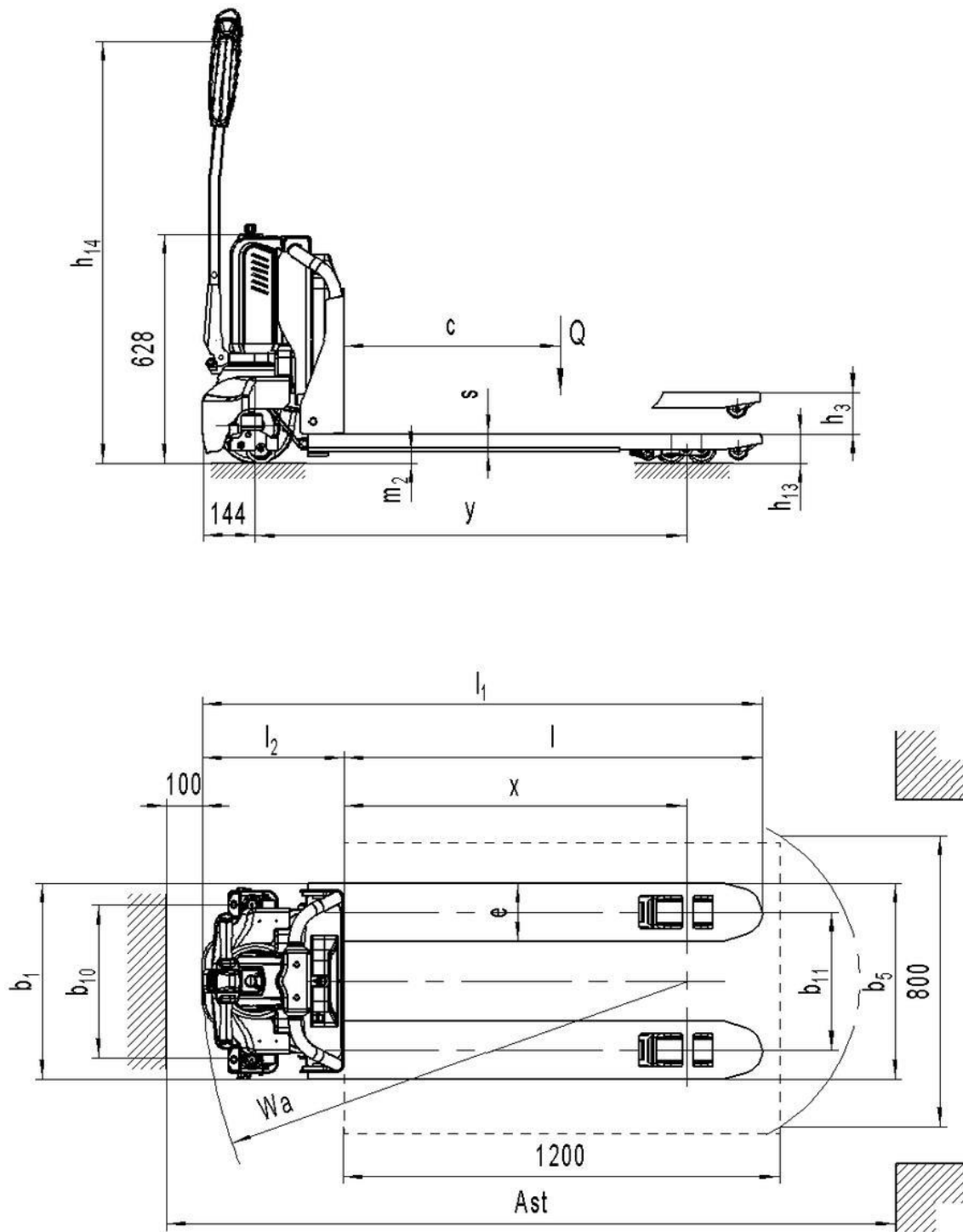

Fig. 19: Technical data US

Table 11: Main technical data for standard version (US market)

Type sheet for industrial truck acc. to VDI 2198			
Distinguishing mark	1.2	Manufacturer's type designation	PT E26N
	1.3	Drive	Battery
	1.4	Operator type	Pedestrian

	1.5	Load Capacity / rated load	Q (lbs)	2600		
	1.6	Load centre distance	c (in)	23.6		
	1.8	Load distance ,centre of drive axle to fork	x (in)	37.1		
	1.9	Wheelbase	y (in)	46.7		
Weight	2.1	Service weight	lbs	273	284	
	2.2	Axle loading, laden front/rear	lbs	783/2143	937/2002	
	2.3	Axle loading, unladen front/rear	lbs	223/60	234/60	
Tyres, chassis	3.1	Tires		Polyurethane (PU)		
	3.2	Tire size,front	Ø x w (in)	Ø 8.27x2.76		
	3.3	Tire size,rear	Ø x w (in)	Ø 3.15x3.66(Ø 3.15x2.76)		
	3.4	Additional wheels(dimensions)	Ø x w (in)	Ø 3.15x1.18		
	3.5	Wheels,number front/rear(x=driven wheels)		1x/ 2(1x/ 4) or 1x +2/ 2(1x +2/ 4)		
	3.6	Tread, front	b ₁₀ (in)	-/16.5		
	3.7	Tread, rear	b ₁₁ (in)	15	20.7	
Dimensions	4.4	Lift	h ₃ (in)	4.53		
	4.9	Height of tiller in drive position min./ max.	h ₁₄ (in)	27.6 / 45.7		
	4.15	Height, lowered	h ₁₃ (in)	3.15		
	4.19	Overall length	l ₁ (in)	60.5		
	4.20	Length to face of forks	l ₂ (in)	15.2		
	4.21	Overall width	b ₁ (in)	21.3	27	
	4.22	Fork dimensions	s/e/l (in)	1.85 / 6.3 /45.3		
	4.25	Width across forks	b ₅ (in)	21.3	27	
	4.32	Ground clearance, centre of wheelbase	m ₂ (in)	1.3		
	4.34	Aisle width for pallets 39.4X47.2 lengthways (7.9in safe distance)	A _{st} (in)	79		
	4.35	Turning radius	W _a (in)	52.6		
Performance data	5.1	Travel speed, laden/ unladen	mph	3.0/3.2		
	5.2	Lift speed, laden/ unladen	fpm	6.10/7.28		
	5.3	Lowering speed, laden/ unladen	fpm	13.58/10.04		
	5.8	Max. gradeability, laden/ unladen	%	4/ 16		
	5.10	Service brake		Electromagnetic		
Electric- engine	6.1	Drive motor rating S2 60min	HP	0.87		
	6.2	Lift motor rating at S3 10%	HP	0.67		
	6.3	Battery acc. to DIN 43531/ 35/ 36 A, B, C, no		No		
	6.4	Battery voltage, nominal capacity K5	V / Ah	24/ 15		
	6.5	Battery weight	lbs	9.7		
	6.6	Energy consumption acc. to VDI cycle	kWh/h	0.14		
Addition data	8.1	Type of drive control		DC speed Control		
	8.4	Sound level at driver's ear acc. to EN 12053	dB(A)	<70		

12. DECLARATION OF CONFORMITY (valid, if sold within the EU)

[GB] CE Declaration of Conformity

The signatory hereby declares that the specified machine conforms to the EU Directive 2006/42/EC (Machine Directive) and 2014/30/EU (Electro-Magnetic Compatibility, EMC) including their amendments as translated into national legislation of the member countries. The signatory is individually authorized to compile the technical documents.

[D] EG-KONFORMITÄTSEKTLÄRUNG

Der Unterzeichner bescheinigt hiermit, dass die im Einzelnen bezeichnete Maschine den Europäischen Richtlinien 2006/42/EG (Maschinenrichtlinie) und 2014/30/EU (Elektromagnetische Verträglichkeit - EMV) einschließlich deren Änderungen sowie dem entsprechenden Rechtsakt zur Umsetzung der Richtlinien in nationales Recht entspricht. Der Unterzeichner ist bevollmächtigt, die technischen Unterlagen zusammenzustellen.

[E] DECLARACIÓN DE CONFORMIDAD CE

El signatario certifica por medio de la presente que la máquina especificada cumple con las Normas Europeas 2006/42/CE (Normativa para maquinarias) y 2014/30/EU (Compatibilidad electromagnética), incluyendo sus respectivas modificaciones, así como con el decreto-ley para la adaptación de las normas al derecho nacional. El signatario dispone de una autorización individual que le permite compilar la documentación técnica.

[F] DECLARATION DE CONFORMITE CE

Par la présente déclaration, les soussignés certifient que le machines spécifié ci-dessus est conforme à la loi et aux directives européennes 2006/42/CE (directive sur les machines) et 2014/30/EU (compatibilité électromagnétique - CEM), y compris aux modifications qui y sont apportées et à l'arrêté autorisant sa transposition en droit national. Chaque signataire est habilité à établir individuellement la documentation technique.

[NL] EG-KONFORMITEITSVERKLARING

Ondergetekenden verklaren hierbij dat - volgens de nationale wetgeving van de Lidstaten - de hierboven vermelde opgegeven machina beantwoordt aan de bepalingen qua veiligheid bij machines (EG richtlijn 2006/42/EC) en electro-magnetische compatibiliteit (EG richtlijn 2014/30/EU).

Ondergetekenden zijn ieder individueel gemachtigd het technisch dossier samen te stellen.

[P] DECLARAÇÃO DE CONFORMIDADE CE

Pela presente, os signatários certificam que o máquina especificado está conforme às Directivas Europeias 2006/42/CE („Máquinas“) e 2014/30/EU („Inocuidade Electromagnética - IEM“), incluindo as alterações das mesmas e o respectivo decreto-lei para a transposição em lei nacional. Cada um dos signatários está autorizado a proceder à elaboração da documentação técnica.

[I] DICHIARAZIONE DI CONFORMITÀ CE

Il sottoscrittodichiara che il veicolo per trasporto internamacchinaspacificatosoddisfa le Direttive Europee 2006/42/EC (DirettivaMacchine) e 2014/30/EU (Compatibilità elettromagnetica - EMV) comprese le relative modifiche, come pure il rispettivo decreto legislativo per la conversione delle direttive in diritto nazionale. Il sottoscrittisonosingolarmenteautorizzatiallacreazione delladocumentazione tecnica.

[BG] ЕВРОПЕЙСКА ОБЩНОСТ - ДЕКЛАРАЦИЯ ЗА СЪОТВЕТСТВИЕ

Подписаните удостоверяват с настоящето, че подробно описаното машина средство отговаря на европейския норматив 2006/42/EG (норматив за машини) и на 2014/30/EU (електро-магнетична съвместимост), включително с техните промени, както и на съответния указ за прилагане на нормативите в националното право. Подписаните при това са упълномощени поотделно да съставят техническата документация.

[CZ] EG - PROHLÁŠENÍ OSHODĚ

Niž podepsaný tím potvrdzuje, že podrobný popis uvedený stroje odpovídá Evropským směrnici 2006/42/EC (směrnice pro stroje) a 2014/30/EU (elektromagnetická interference - EMV) včetně jejich pozdějších úprav, jakož i příslušným právním výnosům pro uplatnění příslušné směrnice v rámci národního práva. Každý z podepsaných jsou jednotlivě zplnomocněni k vytvoření technických podkladů.

[DK] EF-OVERENSSTEMMELSE ERKLÆRING

Undertegnede attesterer hermed, at det specificerede maskine stemmer overens med de Europæiske Direktiver 2006/42/EU (maskindirektiv) og 2014/30/EU (elektromagnetisk kompatibilitet - EMC) samt med den modsvarende lovvedtagelse til implementering af direktiver i den nationale lovgivning. De undertegnede er hver for sig beføjet til at sammenstille de tekniske dokumenter.

[EST] EL vastavusavaldus

Allakirjutatud töendavad käesolevaga, et üksikasjaliselt kirjeldatud täpsustatud masin vastab Euroopa direktiividele 2006/42/EÜ (Direktiiv masinate kohta) ja 2014/30/EU (Elektromagnetiline sobivus - EMS) kaasa arvatud nende muudatused ja nende vastavatele õigusmäärustele direktiivide muutmiseks siseriiklikuks õiguseks. Iga allakirjutanu üksikult on volitatud koostama tehnilist dokumentatsiooni.

[FIN] EU-YHDENMUKAISUUSSELÖSTUS

Allekirjoittaneet todistavat täten, että kukin erikseen mainittu omalla voimalla lähteellä varustettujen koneiden vastaa EU-direktiivien 2006/42/EC (koneiden rakennusdirektiivi) ja 2014/30/EU (sähkömagneettinen yhteensopivuus - EMC) määräyksiä sekä niiden muutoksia ja niiden kansalliseen lainsäädäntöön soveltamista koskevaa oikeussäätöä. Jokaisella allekirjoittaneista on oikeus itsenäisesti laatia asiaankuuluvia teknisiä asiakirjoja.

[GR] ΔΗΛΩΣΗ ΣΥΜΜΟΡΦΩΣΗΣ ΕΚ

Οι υπογράφωντες βεβαιώνουν διά της παρούσης ότι το συγκεκριμένο μηχανήμα συμμορφώνεται προς την Κοινοτική Οδηγία 2006/42/ΕΚ («Μηχανήματα») και 2014/30/ΕΥ (Ηλεκτρομαγνητική Συμβατότητα, ΗΜΣ), καθώς και οι τροποποιήσεις τους, όπως μεταφράστηκαν στην ελληνική νομοθεσία των χωρών μελών.

Οι υπογράφωντες είναι σε κάθε περίπτωση εξουσιοδοτημένοι να καταρτίσουν τα τεχνικά έγγραφα.

[H] EU KONFORMITÄSI NYILATKOZAT

Alulírottak ezennel igazolják, hogy a részletesen leírt a megadott gép megfelel a 2006/42/EC (Gép-Írányelv) és a 2014/30/EU (Elektromágneses összeférhetőség - EMV) Európai Irányelveknek, beleértve azok módosításait, valamint az irányelvek nemzeti jogba történő átültetésére irányuló megfelelő jogi rendelkezést. Továbbá az alulírottak mindegyike rendelkezik meghatalmazással arra nézve, hogy összeállíthatja a műszaki dokumentációt.

[LT] ES atitikimø deklaracija

Žemiau pasirašę asmenys patvirtina, kad atskirai aprašytas nurodyta mašina atitinka Europos Sąjungos direktyvas 2006/42/EB (Mašinų direktyva) ir 2014/30/EU (Elektromagnetinis suderinamumas – EMS) įskaitant jų pakeitimus, o taip pat ir atitinkamą teisės aktą dėl direktyvų įgyvendinimo nacionalinėje teisėje. Kiekvienas iš pasirašiusių asmenų turi teisę ruošti techninę dokumentaciją.

[LV] ES atbilstības deklarācija

Ar zemāk redzamajiem parakstiem tiek apliecināts, kanorādīts mašina atbilst Eiropas Savienības normatīvam 2006/42/EG (Mašīnu normatīvas) un 2014/30/EU (Elektromagnētiskā atbilstība – EMV), ieskaitot to izmaiņus, kā arī atbilstošos tiesiskos rīkojumus normatīvu pielāgošanai

nacionālajai likumdošanai. Parakstu īpašnieki ir atsevišķi pilnvaroti sastādīt tehniskās dokumentācijas.

[N] EU-KONFORMITETSERKLÆRING

Undertegnede bekræfter hermed at de enkelte betegnede maskin med kraftdrift tilsvarer de europeiske retningslinjerne 2006/42/EC (maskinretningslinje) og 2014/30/EU (elektromagnetisk fordraglighed - EMV) inklusiv disses endringer og den tilsvarende rettsforordning til omsetning av nasjonal rett. Hver undertegnede er fullmektig til å sette sammen de tekniske dokumentene.

[PL] DEKLARACJA ZGODNOŚCI WE

Niżej podpisani deklarują, że poniżej opisana maszyna spełnia wymagania określone w dyrektywach Europejskich 2006/42/EC (Dyrektywa Maszynowa) i 2014/30/EU (Kompatybilności elektromagnetycznej - EMC) wraz z ich późniejszymi zmianami oraz odpowiednimi rozporządzeniami mającymi na celu przeniesienie tych dyrektyw do prawa krajów członkowskich. Sygnatariusz jest indywidualnie upoważniony do zestawiania dokumentacji technicznej.

[RO] DECLARAȚIE DE CONFORMITATE CE

Subsemnatii adeveresc prin prezenta ca vehiculul despecificat mașină descriș individual corespondedirectiveloreuropene 2006/42/CE (Directivaprivindmașinile) și 2014/30/EU (Compatibilitateaelectromagnetică - CEM) inclusivmodificărilorlor precum șiactululegislativcorespunzătorpentrutranspunereadirectivelorîndreptnațional. Subsemnatii sunt fiecareînparteîmpunernicițisăîntocmeascădocumentațiatehnică.

[RU] Декларация соответствия стандартам ЕС

Настоящим лица, подписавшие документ, удостоверяют, что машина с указанной спецификацией соответствует европейским стандартам 2006/42/EG (Транспортная директива) и 2014/30/EU (Электромагнитная совместимость - EMC), включая изменения в них, а также соответствующим национальным стандартам и нормам. Каждое по отдельности лицо, подписавшее документ, имеет полномочия для составления технической документации.

[S] EG-KONFORMITETSFÖRKLARING

Undertecknarna intygar härmed att det i detalj betecknade maskin uppfyller de Europeiska direktiven 2006/42/EG (Maskindirektiv) och 2014/30/EU (Elektromagnetisk tålighet - EMV), inklusive ändringarna i detta och den motsvarande rättsförordningen för att omsätta direktiven i nationell rätt. Undertecknarna har var för sig fullmakt att sammanställa den tekniska dokumentationen.

[SK] vyhlášení o zhode

Dolu podpísaní týmto potvrdzujeme, že podrobný popis uvedené stroje zodpovedá Európskym smerniciam 2006/42/EC (ernica pre stroje) a 2014/30/EU (elektromagnetická tolerancia – EMV) vrátane jeho neskorších úprav, rovnako zodpovedá aj príslušným právnym nariadeniam na uplatnenie smerníc v rámci národného práva. Každý z podpísaných je jednotlivo splnomocnený na vytvorenie technických podkladov.

[SLO] EU IZJAVA O SKLADNOSTI

Podpisani s tem potrjujemo, da posamično označeno določeno stroj vozilo odgovarja Evropski direktivi 2006/42/EC (Direktiva o strojih) in 2014/30/EU (Elektromagnetna skladnost - EMV) vključno z njihovimi spremembami ter ustrezno pravno uredbo o prevzemu smernic v nacionalno pravo. Podpisniki so vsakokrat posamezno pooblašteni za izdajanje tehnične dokumentacije.

[TR] AB Uygunluk Açıklaması

İmza sahibi şahıslar, ayrıntıları belirtilen makine aracının, 2006/42/EC (Makine Yönergesi) ve 2014/30/EU (Elektromanyetik Uyumluluk – EMC) no'lu Avrupa Yönergelerine ve bunların değişiklik sonucu oluşan metinlerine ve yönergelerin milli hukuk hükümlerine dönüştürülmesine dair ilgili hukuk karamamesine uygun olduğunu tasdik ederler. İmza sahibi şahıslar teknik dosyaları bir araya getirmek için münferiden vekil tayin edildi.

- (1) Type/ Typ/ Tipo/ Modello/ Түппи/ Tipo / ΤΥΠΟΣ/ Típus/ Tip/ Тип/ Tips/ Tipas/ Tüüp:
- (2) Serial No./ Serien-Nr./ N°. de série/ Seriennummer/ N° de serie/ Numero di serie/ Serienr./ Sarjanro/ αυξάνων αριθμός/ Seriové číslo/ Szériaszám/ Nr. Seryjny/ Serijska številka/ Výrobné číslo/ Серийный номер/ Seri No./ Seerianr./ Séríjas Nr./ Serijos numeris:
- (3) Year of constr./ Baujahr/ Année de constr./ Bouwjaar/ Año de constr./ Anno di costruzione/ Produktionsår/ Byggeår/ Tillverkningsår/ Valmistusvuosi / Ano de fabrico / έτος κατασκευής/ Rok výroby/ Gyártási év/ Rok produkcji / Letnik / Год изготовления / Üretim yılı / Väljalaskeaasta / Izgatavošanas gads / Gamybos metai
- (4) Manufacturer or his authorized representative in Community/ Hersteller oder in der Gemeinschaft ansässiger Vertreter/ Fabricant ou son mandataire établi dans la Communauté/ Fabrikant of zijn in de Gemeenschap gevestigde gemachtigde/ Fabricante o representante establecido en la Comunidad/ Construtor ou representante estabelecido na Comunidade/ Costruttore oppure il suo rappresentante nella Comunità/ Fabrikant eller dennesi Fællesskabet etablerede befuldmægtigede/ Producent eller agent innen felleskapet/ Tillverkare eller representant inom EU/ Valmistaja tai yhteisömaassaoleva edustaja / V'robcenebojehozastoupeni/ Gyártó / producent albo jego przedstawiciel w EG (Wspólnota Europejska)/ Κατασκευαστής ή ο κληννομηθηθώλ αληητηζώπσο/ Üretici ya da Bölgedeki Yetkili Temsilci/ Proizvajalec ali pooblaščen zastopnik s sedežem v EU/ Výrobca alebo zástupca so stálym bydliskom v EÚ / Изготовитель или его представитель, зарегистрированный в стране Содружества/ Tootjavõõorganisatsioonipaiknevesindaja/ Ražotājs vai vietējais uzņēmuma pārstāvis / Gamintojas arba šalį jereziduojančias atstovas:
- (5) Date/ Datum/ Data/ Fecha/ datum/ Dato/ päiväys/ Kuupäev/ Datums/ дата/ Datum/ dátum/ tarih/ πυρομηνία
- (6) Authorised signatory/ Im Auftrag/ pour ordre/ Incaricato/ Por orden de/ por procuração/ op last van/ på vegne af/ på uppdrag/ Etter oppdrag/ psta./ Ülesandel / pavedus / v. i. / Попоручению / megbízásából / длъжностно лице / z pověřením / z poverenia / po nalogu / napolecenie / din sarcina / adina / θαν' εληνη

- Sample*
If you can read this text, your declaration is not complete. In this case please ask for a copy
- (1) Type: **XX XX – Self-propelled industrial truck**
 - (2) Serial No: **XXXXXXXX**
 - (3) Year of constr.: **YYYY**
 - (4) Manufacturer or his authorized representative in Community:
Company name/ Street / Postal code Town/ Country
 - (5) Date: **YYMM.DD**
 - (6) Authorized signatory: **Mr. Sample**