

# NOBLELIFT



Scan it,

For more information

**Standing Tow Tractor**

**T50N/T30N**

**SPARE PARTS LIST**



Version: 06/2020

From truck identification number:

20200302018 Spare Parts List

T50N/T30N-BPT-001-EN

Please order spare parts from an authorized dealers of Noblelift Intelligent Equipment Co., LTD.

In order to avoid wrong shipping, all the orders of parts should be marked with the following items:

- Truck model, manufacturing number and year of manufacture.
- When ordering spare parts for mast, hydraulic parts, steer bridge and motor, the manufacturing number shall be noted.
- The article number for spare parts of Noblelift are shown in the spare parts list. Please also pay attention to the mark of supply status and order quantity, etc. (the number listed in "Mark" column of the spare parts list).

"Mark" column:

The unmarked number indicates the lead time for these parts is short.

Number 1: Supply as package. Indicating that supply the small parts or sealing parts as packages, with its minimum quantity for each package, the lead time for these spare parts is short.

Number 2: Supply with limit. Indicating that these parts are not in stock and will be prepared for production after receiving the order from the customer. The lead time may be long.

Number 3: Phasing out supply. Indicating that due to technical improvements, these parts are replaced by new parts and will not be supplied after current stock run out. Please check the corresponding explanations.

Number 4: Supply as assembly. Indicating that these parts are assembly parts specified by the manufacturing process, which cannot be supplied as single part.

Number 5: Check other lists. This list is the property of Noblelift and can be shared under the confidential agreement only, Noblelift has the right to claim for compensation. Copy is not allowed without the permission of Noblelift. The figures are not limited by the original design structure. Noblelift Intelligent Equipment Co., LTD reserves the right to improve the products to adapt to the continuous progress of technology.

# Contents

Chapter 1: Drive system .....	5
01 Drive unit (567746013501) .....	5
Chapter 2: Truck structure .....	7
01 Truck frame (567746021501) standard version .....	7
02 Truck frame (567746021501) optional version .....	9
03 Platform (566546018001) .....	11
04 Side wheel (566546016501) .....	13
05 Load wheel (567746017001) .....	15
Chapter 3: Steering system, braking system, wheels .....	17
01 Operating panel (566546010001) .....	17
02 Tiller head (566546010002) .....	19
Chapter 4: Special parts .....	21
01 Beacon (567746035501) .....	21
Chapter 5: Electrical parts .....	23
01 Electronic control components (567746033001) .....	23
02 Wire harness assembly (567446033002) .....	25
03 Charger (567746036501) .....	27
04 Traction battery (567446037001) .....	29
Chapter 6: Others .....	31
01 Labels and decals (US) (567746047001) .....	31
02 Labels and decals (EU) (567746047002) .....	33
Appendix .....	35
01 Electrical circuit diagram -T50N (standard) .....	35
02 Electrical circuit diagram -T50N (optional) .....	36
03 Electrical circuit diagram -T30N (standard) .....	37
04 Electrical circuit diagram -T30N (optional) .....	38
05 Easy worn parts list .....	39



## Chapter 1: Drive system

### 01 Drive unit (567746013501)

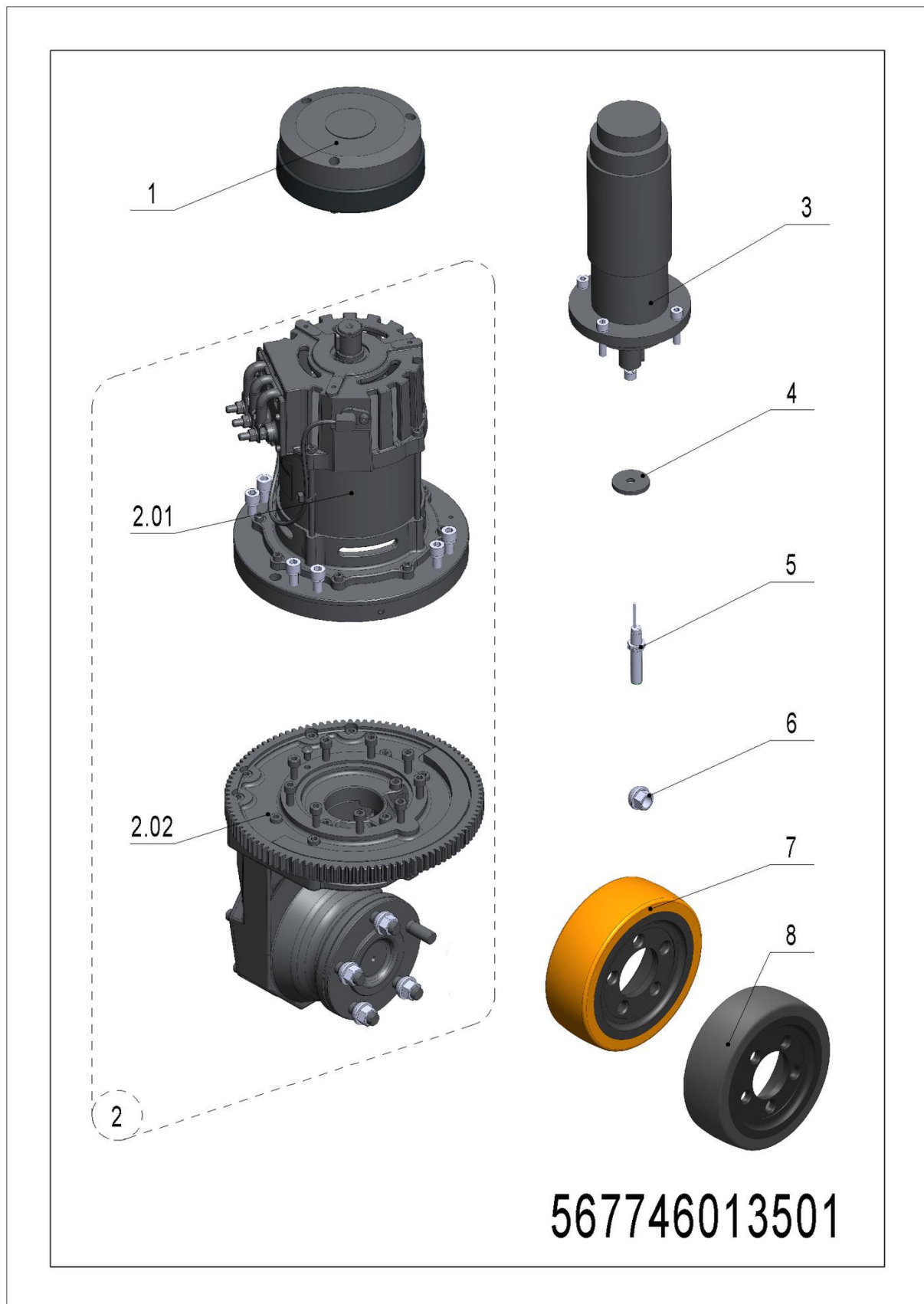

## 01 Drive unit (567746013501)

No.	Art No.	Mark	Description	Qty.	Substitute No.	Note
1	940700100002		Brake 24V32NM	1		T50N
1	940700100001		Brake 24V12NM	1		T30N
2	940900600004		Drive assembly AC2.6KW	1		T50N
2.01	565998510002	2	Motor	1		T50N
2.02	565998510003	2	Gear	1		T50N
2	940900600006		Drive assembly AC1.9KW	1		T30N
2.01	567498510000	2	Motor	1		T30N
2.02	567498510001	2	Gear	1		T30N
3	920900100050		Motor (DC) Z90DPN24400-30S	1		
4	506013520001		Washer	1		
5	565933510001		Proximity switch Fi4-M12-ON6L-L70	1		
6	275015520005		Nut M14x1.5	5		T50N
6	567413520000		Nut M12x1.5	5		T30N
7	940300400026		Wheel (Non-marking) $\Phi$ 250x80	1		T50N (PU)
7	940300400027		Wheel (Non-marking) $\Phi$ 230x70	1		T30N (PU)
8	940300400019		Drive wheel $\Phi$ 250x80	1		T50N (rubber)
8	940300400020		Drive wheel $\Phi$ 230x70	1		T30N (rubber)

## Chapter 2: Truck structure

### 01 Truck frame (567746021501) standard version

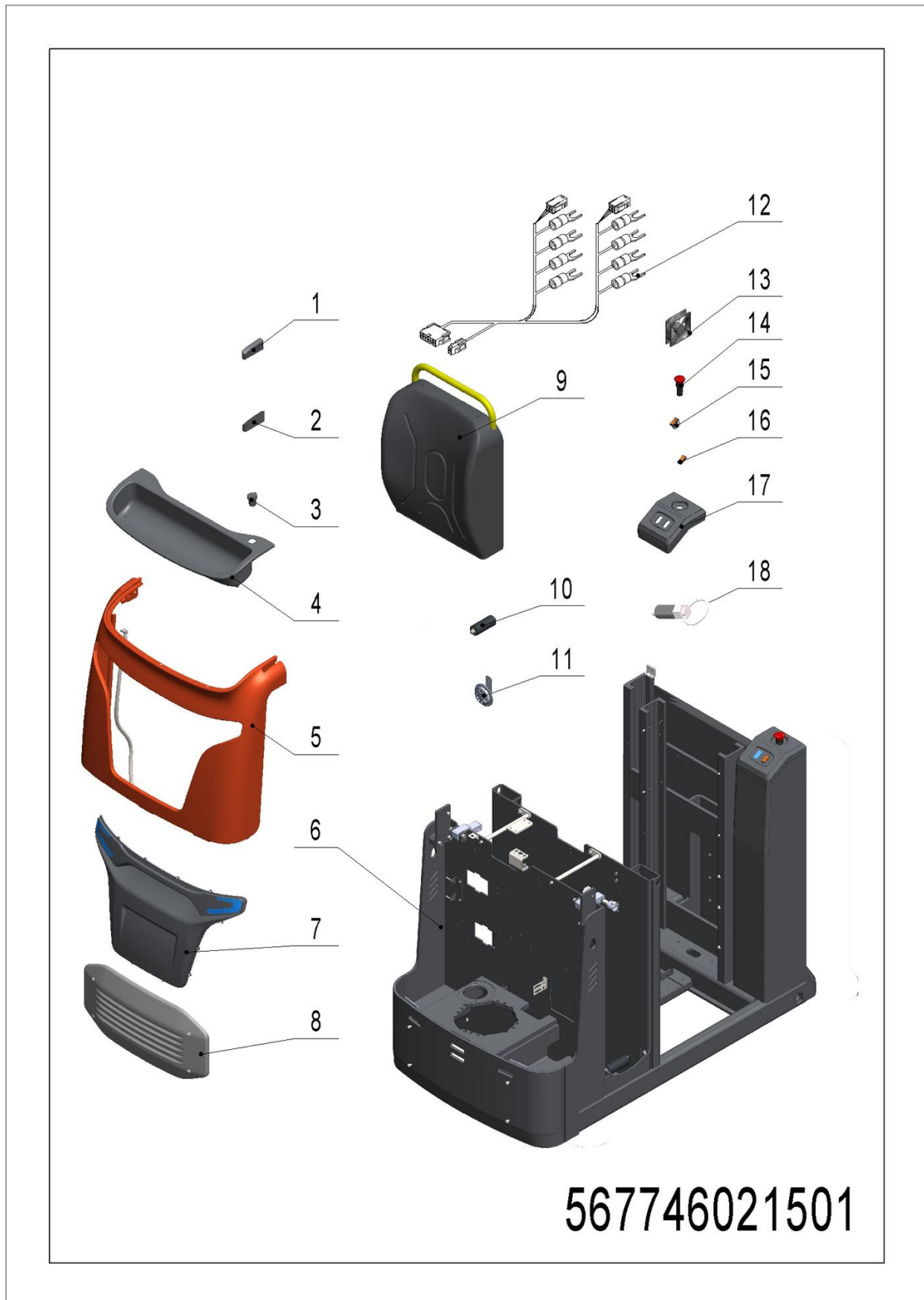

## 01 Truck frame (567746021501) standard version

No.	Art No.	Mark	Description	Qty.	Substitute No.	Note
1	566521520082		Rubber plug (left)	1		
2	566521520083		Rubber plug (right)	1		
3	921900100004		Converter DC (24V to 5V)	1		
4	566521520096		Storage compartment	1		
5	566521520092		Front panel	1		
6	567721510000	2	Chassis welding	1		T50N
6	567421510000	2	Chassis welding	1		T30N
7	566521520093		Front decoration panel	1		
8	566521520097		Buffer	1		
9	566521520081		Backrest	1		
10	565921510005		Roller component	8		
11	920500100001		Horn 125-DC24V	1		
12	567733010008		Jog switch wire harness	1		
13	920300100003		Fan DC24V-90x90	1		
14	920200100021		Emergency button CE4T-10R-02	2		
15	920200800005		Switch 3203-00092-OAJ	2		
16	920200800007		Seal cover	2		
17	566521520098		Emergency button base	2		
18	940801000001		Pin with loop	1		

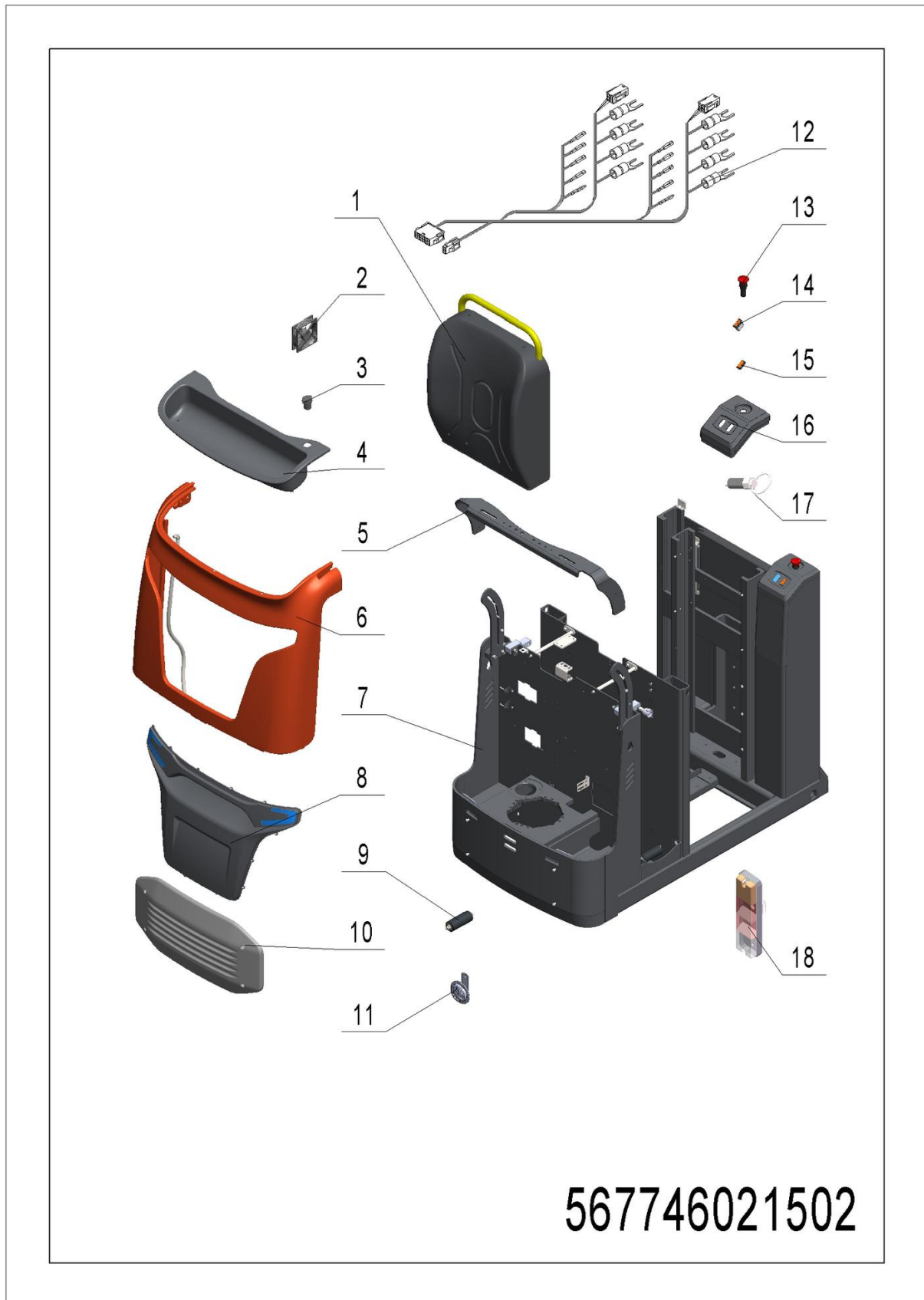

**02 Truck frame (567746021501) optional version**

## 02 Truck frame (567746021501) optional version

No.	Art No.	Mark	Description	Qty.	Substitute No.	Note
1	566521520081		Backrest	1		
2	920300100003		Fan DC24V-90x90	1		
3	921900100004		Converter DC (24V to 5V)	1		
4	566521520096		Storage compartment	1		
5	566521520070		Accessories' bracket	1		
6	566521520092		Front panel	1		
7	567721510000	2	Chassis welding	1		T50N
7	567421510000	2	Chassis welding	1		T30N
8	566521520093		Front decoration panel	1		
9	565921510005		Roller component	8		
10	566521520097		Buffer	1		
11	920500100001		Horn 125-DC24V	1		
12	567733010001		Jog switch wire harness	1		
13	920200100021		Emergency button CE4T-10R-02	2		
14	920200800005		Switch 3203-00092-OAJ	2		
15	920200800007		Seal cover	2		
16	566521520098		Emergency button base	2		
17	940801000001		Pin with loop	1		
18	922000100003		Tri-color taillight	2		

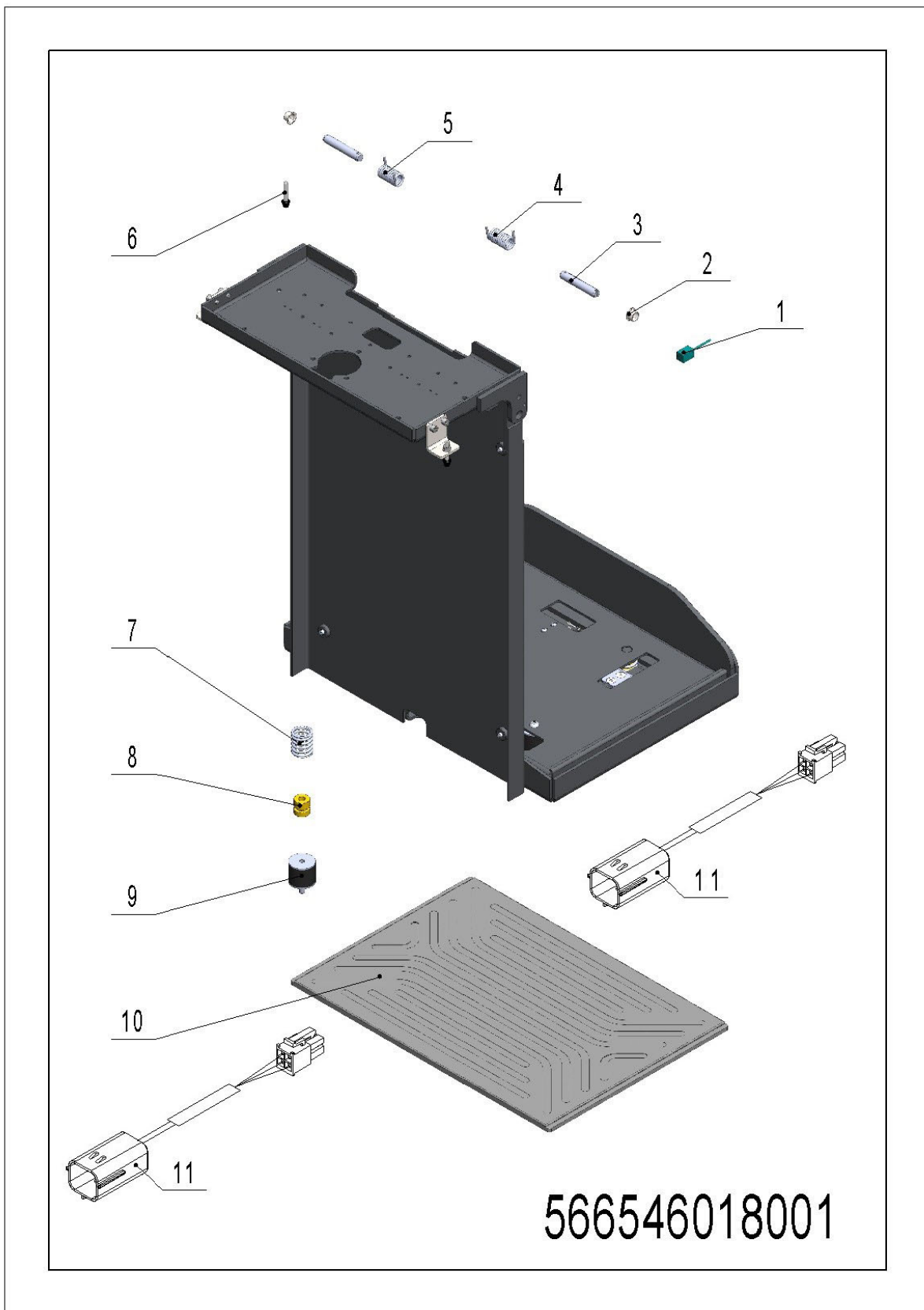
**03 Platform (566546018001)**

## 03 Platform (566546018001)

No.	Art No.	Mark	Description	Qty.	Substitute No.	Note
1	502311010001		Proximity switch NBN5-F7-E2 (80mm)	1		
2	940500200018		18x12	2		
3	566518020030		Axle $\Phi$ 16x90	2		
4	566518020031		Left torsion spring $\Phi$ 22x $\Phi$ 4x50	1		
5	566518020032		Right torsion spring $\Phi$ 22x $\Phi$ 4x50	1		
6	566518020086		Cushion plug M8x54	2		
7	940400500004		Spring $\Phi$ 40x $\Phi$ 5x55	2		
8	566518020033		Cushion washer $\Phi$ 30x $\Phi$ 13x31	2		
9	566518020088		Damper	2		
10	566518020093		Foot pad	1		
11	566533010024		Interlock switch wire harness	1		T50N, OPL25N/12/20SF
11	567433010009		Interlock switch wire harness	1		T30N

**04 Side wheel (566546016501)**

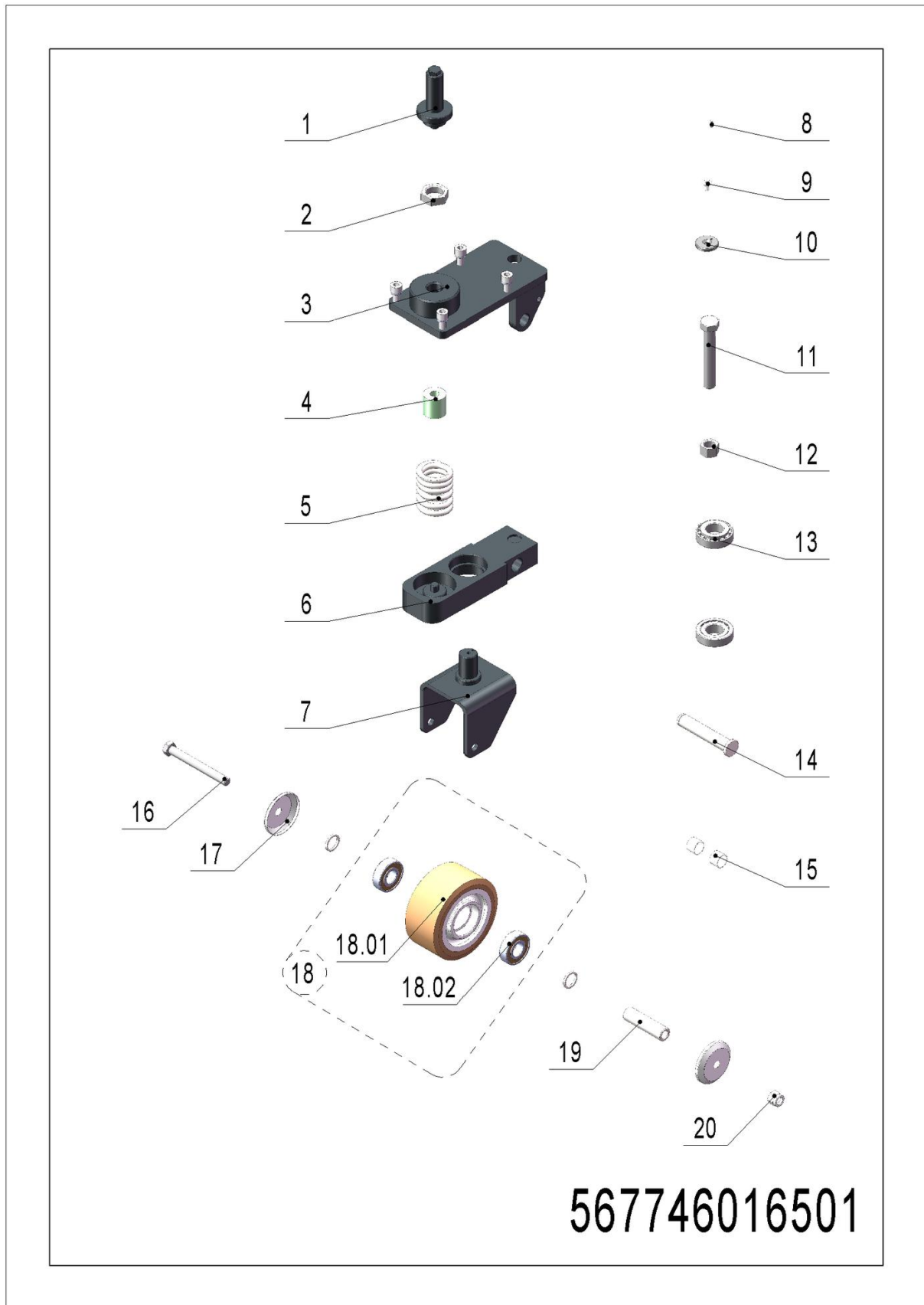

## 04 Side wheel (566546016501)

No.	Art No.	Mark	Description	Qty.	Substitute No.	Note
1	505916520001		Adjusting bolt M24x1.5x58	1		
2	300572020006		Nut M24x1.5	1		
3	567716510000		Fixed plate welding	1		
4	505616520000		Spring (PU)	1		
5	940400500007		Spring $\Phi 43 \times \Phi 9 \times 62$	1		
6	567716510001		Linking plate welding	1		
7	505916510003		Wheel frame welding	1		
8	910600100004	1	Cylindrical pin GB119.2-4x14	1		
9	910200400040	1	Blot GB70.3-M8x12-8.8	1		
10	505616520007	1	Washer $\Phi 32 \times \Phi 7 \times 5$	1		
11	910100300072	1	Blot GB5783-M16x100-8.8	1		
12	910300100010	1	Nut GB6170-M16-10	1		
13	910700600001		Bearing GB297-30205	2		
14	567716520006		Axle $\Phi 20 \times 95$	1		
15	940500100010		Bushing $\Phi 18 \times \Phi 20 \times 15$	2		
16	910100100059	1	Blot GB5782-M12x110-8.8	1		
17	505916520010		Dustproof cap $\Phi 70 \times \Phi 55 \times 10$	2		
18	567798510002		Wheel assembly	1		
18	940300300019		Wheel (PU) $\Phi 124 \times 60$	1		
18	910700200019		Bearing GB276-6204-2RS	2		
19	505916520009		Axle sleeve $\Phi 20 \times \Phi 12 \times 73$	1		
20	910300500006	1	Nut GB889.1-M12-10	1		

**05 Load wheel (567746017001)**

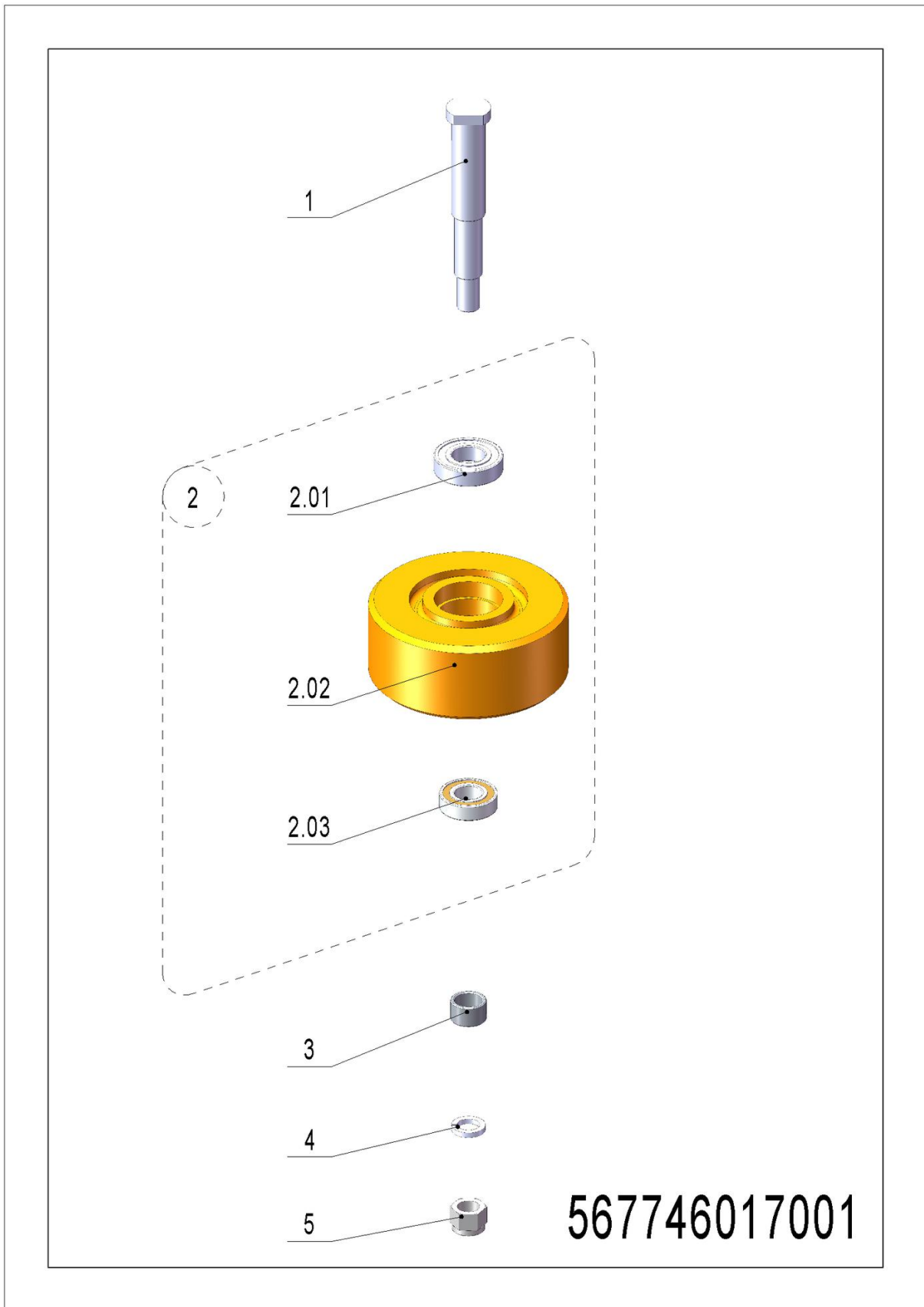

## 05 Load wheel (567746017001)

No.	Art No.	Mark	Description	Qty.	Substitute No.	Note
1	567717020000		Wheel axle	2		
2	567798510003		Wheel assembly	2		
2.01	910700200021		Bearing GB276-6206-2RS	2		
2.02	940300300022		Wheel $\Phi$ 180x76-C160323	2		
2.03	910700200020		Bearing GB276-6205-2RS	2		
3	567717020001		Axle sleeve $\Phi$ 32x $\Phi$ 25x20	2		
4	910400500012		Washer GB93-20	2		
5	910300500010		Nut GB889.1-M20-10	2		



Chapter 3: Steering system, braking system, wheels

01 Operating panel (566546010001)



## 01 Operating panel (566546010001)

No.	Art No.	Mark	Description	Qty.	Substitute No.	Note
1	566533010003		Tiller wire harness	1		
2	922100100007		Tiller 94300-90 (REMA)	1		
3	566511020000		Connection plate	1		
4	566531520009		Connection base	1		
5	566534510001		Blue-ray light	1		
6	566518020090		Top panel	1		
7	566518010011		Lock catch M12x100	1		
8	921900100006		Converter DC (24V to 5V)	1		
9	566531501000		Electric steering unit	1		
9.01	566531520006		Spring $\Phi 70 \times \Phi 3.5 \times 37$	1		
9.02	566531520004		Axle sleeve	2		
9.03	910700200019		Bearing GB276-6204-2RS	2		
9.04	566531520005		Sleeve(PA)	1		
9.05	565931520005		Connection block	1		
9.06	565933510000		Potentiometer	1		
10	566598510002		Indicator support assembly	1		
10.01	566533010021	2	Pin-code lock DTK00005C	1		
10.02	566518020091	2	Indicator support	1		
11	921100100076		Indicator 003401-89017AAA	1		T30N
11	921100100077		Indicator 003402-89017AAA	1		T50N,OPL25/12/20SF
12	920200100021		Emergency button CE4T-10R-02	1		
13	566533010019		Emergency button wire harness	1		
14	566533010026		USB harness	1		

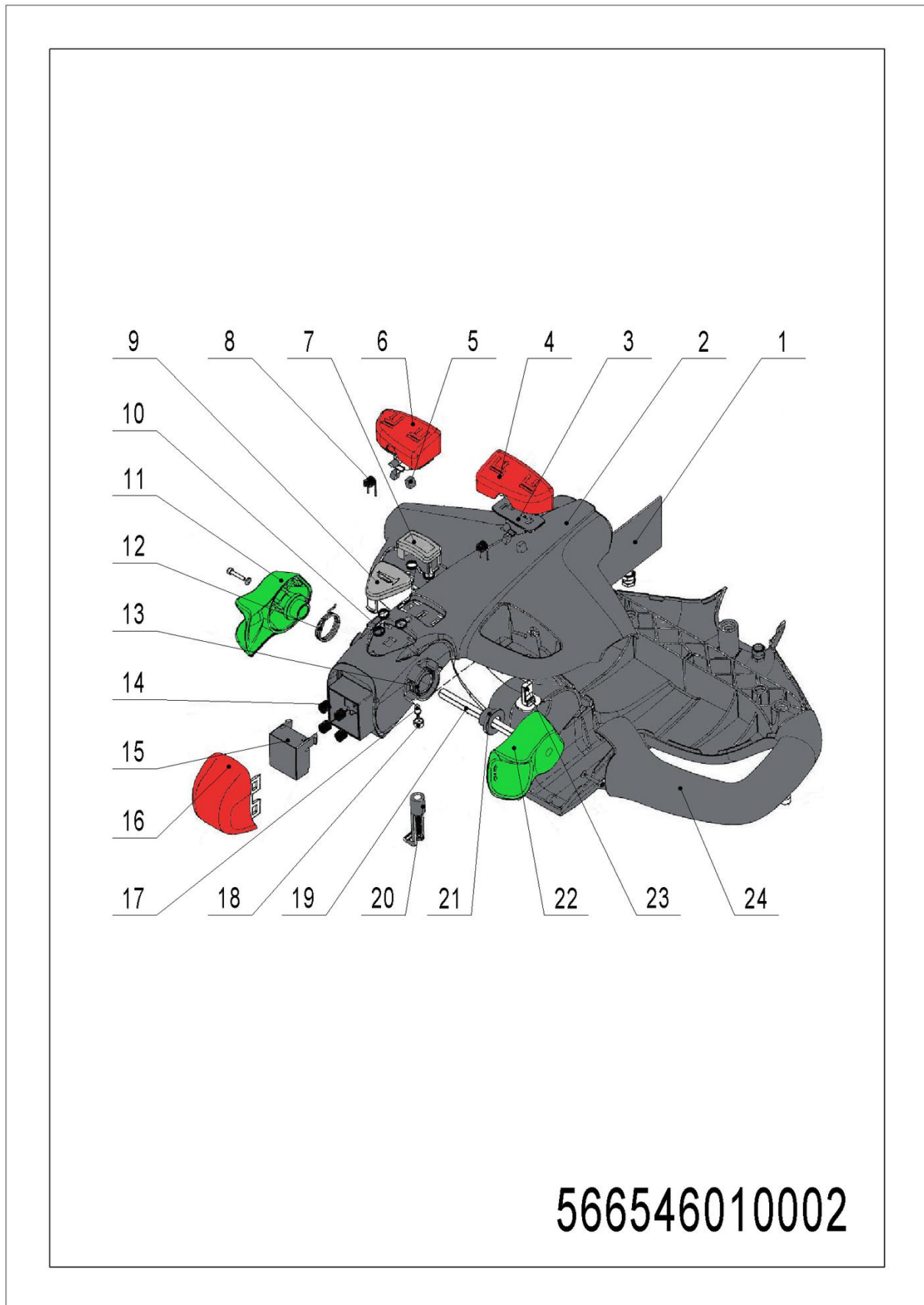
**02 Tiller head (566546010002)**

## 02 Tiller head (566546010002)

No.	Art No.	Mark	Description	Qty.	Substitute No.	Note
1	505698520028		PCB	1		
2	505698520014		Tiller upper part	1		
3	505698520017		Magnetic support	2		
4	505698520022		Right button	1		
5	505698520005		Magnet	4		
6	505698520016		Left button	1		
7	505698520021		Turtle speed switch	1		
8	505698520018		Torsion spring	2		
9	505698520002		Horn button	1		
10	505698520003		Horn button spring	5		
11	505698520001		Left drive knob	1		
12	505698520027		Left drive knob torsion spring	1		
13	505698520026		Right drive knob torsion spring	1		
14	505698520006		Emergency button spring	4		
15	505698520019		Emergency button base	1		
16	505698520020		Emergency button cover	1		
17	505698520024		LED bi-colour lamp	1		
18	505698520025		LED bi-colour lamp holder	1		
19	505698520011		Drive knob axle	1		
20	505698520012		PCB clamp	1		
21	505698520004		Camshaft bushing	2		
22	505698520010		Right drive knob	1		
23	505698520013		Sensor	2		
24	505698520015		Tiller bottom part	1		

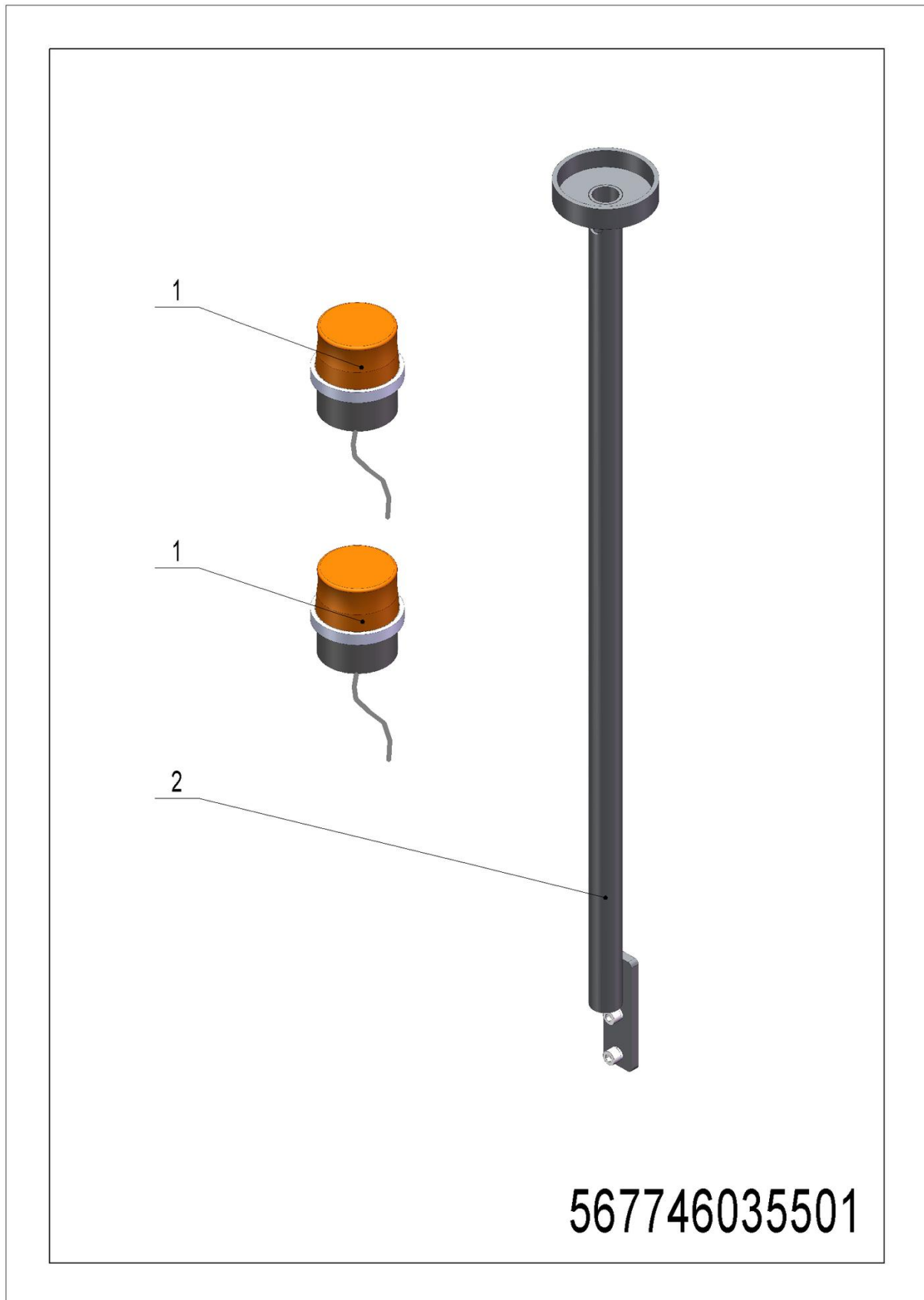
**Chapter 4: Special parts****01 Beacon (567746035501)**

## 01 Beacon (567746035501)

No.	Art No.	Mark	Description	Qty.	Substitute No.	Note
1	231033010020		Beacon harness (light)	1		
1	231033010021		Beacon harness (light and sound)	1		Optional
2	567735510000		Mounting bracket welding	1		

## Chapter 5: Electrical parts

### 01 Electronic control components (567746033001)

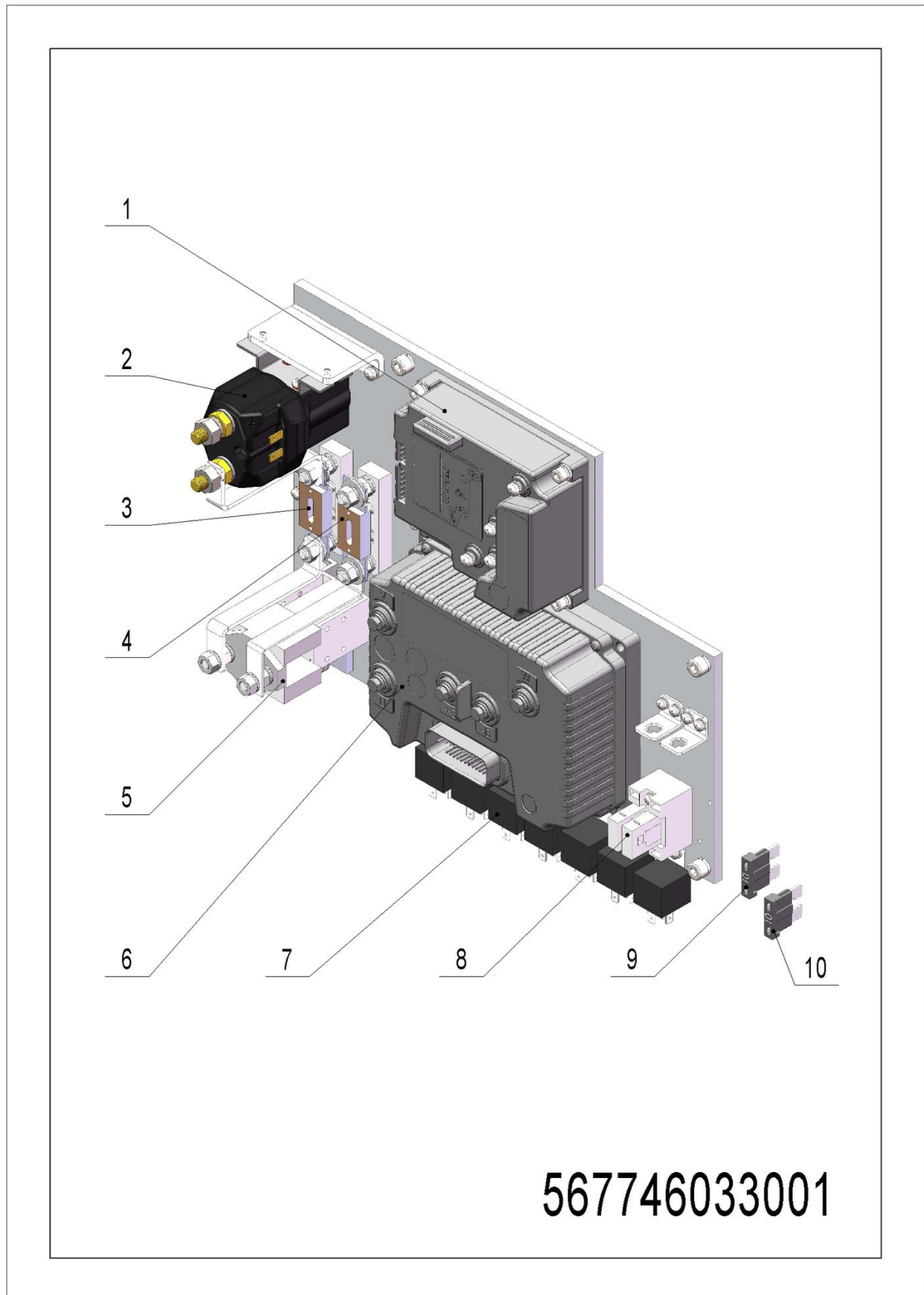

## 01 Electronic control components (567746033001)

No.	Art No.	Mark	Description	Qty.	Substitute No.	Note
1	921400100030		Controller EPS-DC0-24V-50A	1		
2	920700100015		Contacteur DC24V350A	1		
3	920100100013		Fuse 350A	1		
4	920100100001		Fuse 30A	1		
5	920700100002		Contacteur DC24V-SW180B-4	1		
6	921400100026		Traction controller ACE0-24V320A	1		T50N
6	921400100088		Traction controller ACEx24V-240A	1		T30N
7	920800100011		Relay CMA36-S-DC24V	2/7		
8	920100400005		Fuse holder BD-2x10A-1	1		
9	920100200003		Fuse 15A	1		
10	920100200002		Fuse 10A	1		



## 02 Wire harness assembly (567446033002)

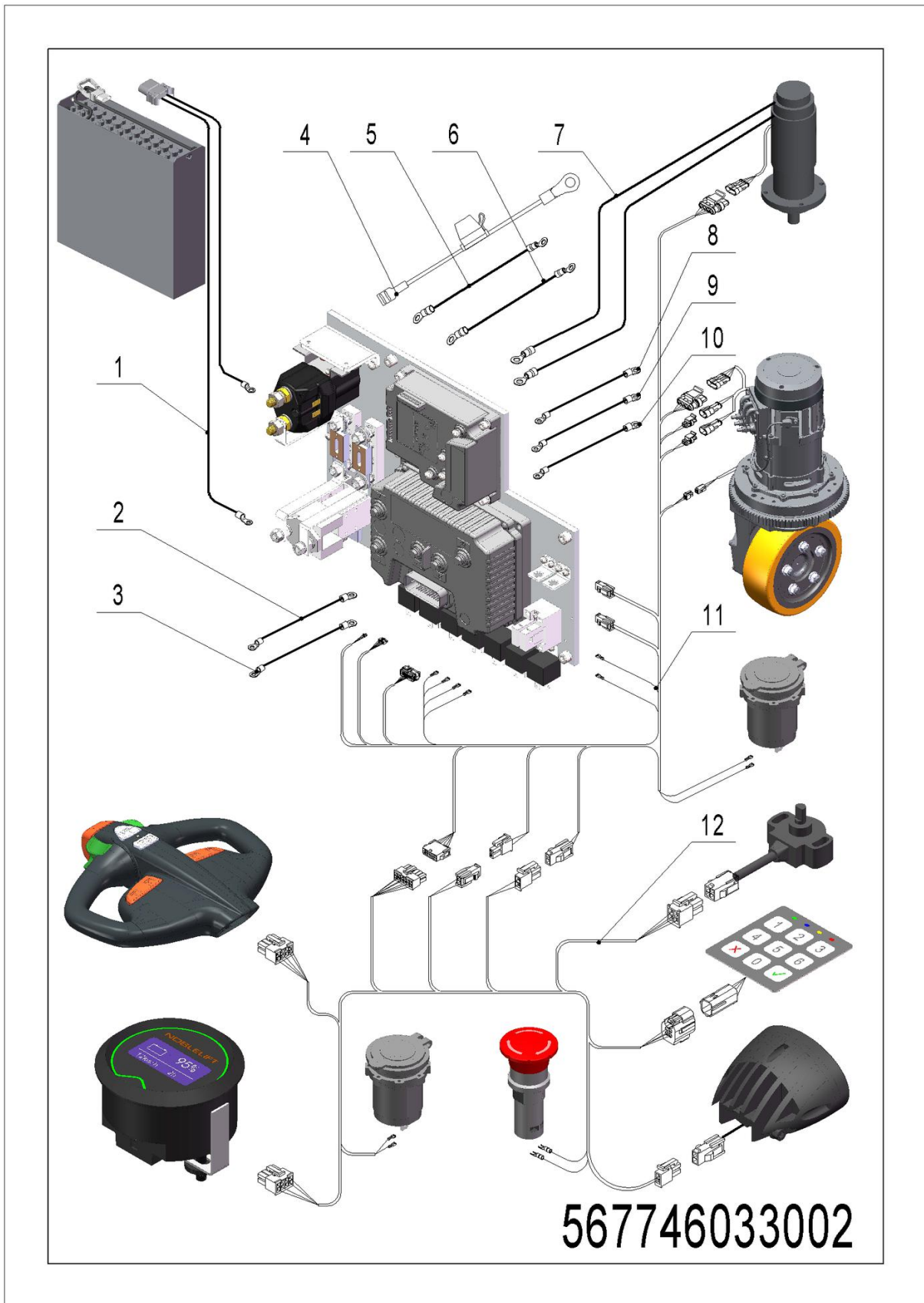

## 02 Wire harness assembly (567446033002)

No.	Art No.	Mark	Description	Qty.	Substitute No.	Note
1	566533010012		Power wire harness	1		Lead-acid battery
1	566533010025		Power wire harness (Li)	1		Lithium battery
2	566533010009		Cable-T+-25-6-8-300	1		
3	566533010017		Cable-B--25-6-8-320	1		
4	566533010016		Contactore wire harness	1		
5	566533010013		Cable-BS+6-5-8-170	1		
6	566533010014		Cable-BS--6-5-8-350	1		
7	566533010008		Steering motor wire harness	1		
8	567733010004		Cable-UT-25-6-8-850	1		T50N
8	567433010005		Cable-UT-25-6-6-850	1		T30N
9	567733010005		Cable-VT-25-6-8-900	1		T50N
9	567433010006		Cable-VT-25-6-6-800	1		T30N
10	567733010006		Cable-WT-25-6-8-1050	1		T50N
10	567433010007		Cable-WT-25-6-8-950	1		T30N
11	567733010007		Main controller wire harness	1		T50N (standard)
11	567733010000		Main controller wire harness	1		T50N (optional)
11	567433010000		Main controller wire harness	1		T30N (standard)
11	567433010001		Main controller wire harness	1		T30N (optional)
12	566533010002		Platform wire harness	1		T50N
12	567433010003		Platform wire harness	1		T30N

**03 Charger (567746036501)**

## 03 Charger (567746036501)

No.	Art No.	Mark	Description	Qty.	Substitute No.	Note
1	921000200492		Charger SN24V45A (Asia-CHN)	1		T30N
1	921000200493		Charger SN24V45A (Asia-EN)	1		T30N
1	921000200494		Charger SN24V45A (EU)	1		T30N
1	921000200496		Charger SN24V45A (AUS)	1		T30N
1	921000200495		Charger SN24V45A (EN)	1		T30N
1	921000200169		Charger SN24V45A (US)	1		T30N
1	921000200073		Charger SN24V60A (Asia-CHN)	1		T50N
1	921000200074		Charger SN24V60A (Asia-EN)	1		T50N
1	921000200075		Charger SN24V60A (EU)	1		T50N
1	921000200076		Charger SN24V60A (EN)	1		T50N
1	921000200077		Charger SN24V60A (AUS)	1		T50N
1	921000200078		Charger SN24V60A (US)	1		T50N
1	921000200483		Lithium battery charger 24V150A	1		Overseas market
1	921000200437		Lithium battery charger 24V150A (Asia-CHN)	1		Domestic market

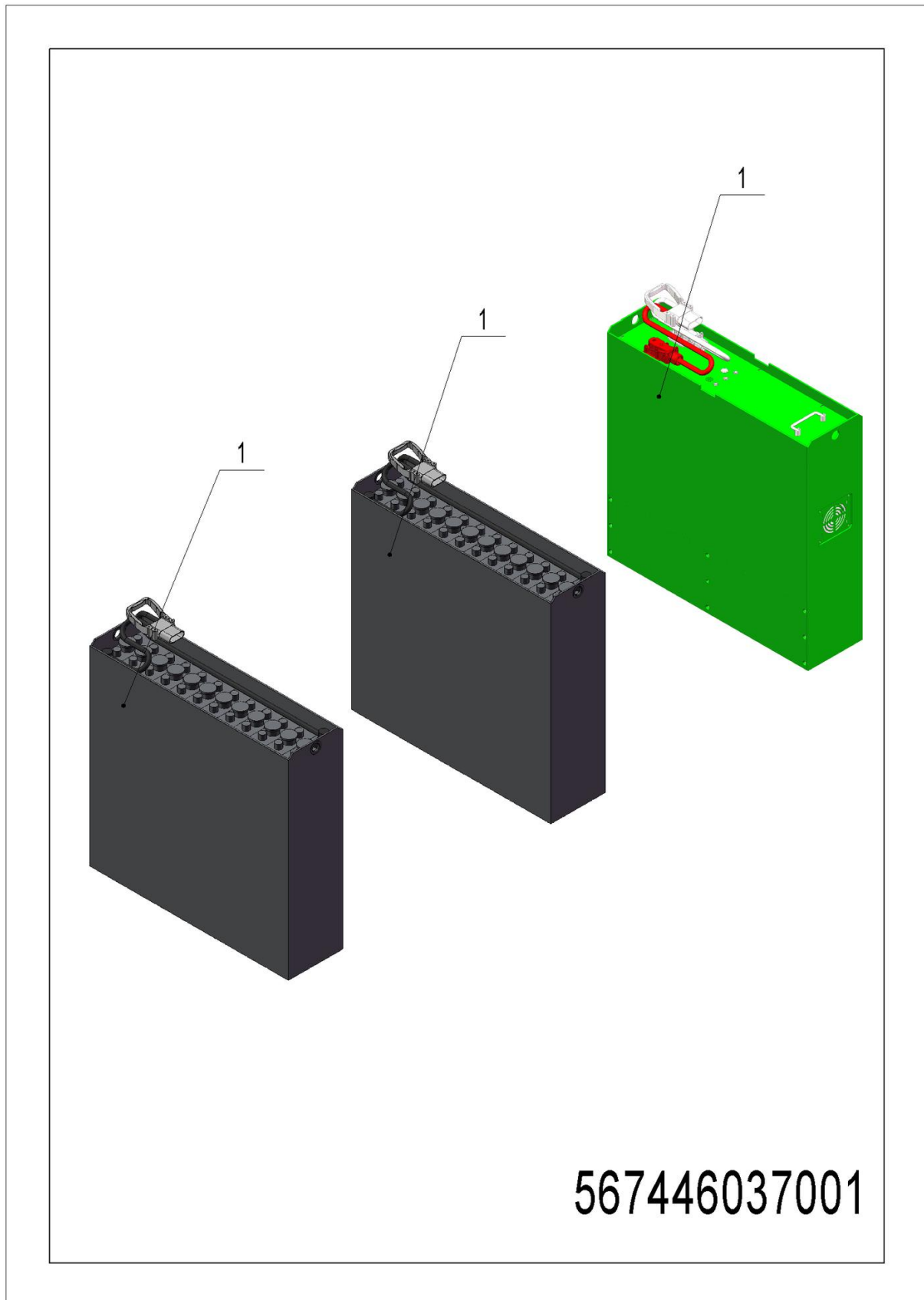
**04 Traction battery (567446037001)**

## 04 Traction battery (567446037001)

No.	Art No.	Mark	Description	Qty.	Substitute No.	Note
1	920600100117		Lithium battery 24V300Ah1HR-3	1		T50N/T30N (optional)
1	566537010000		Lead-acid battery 24V465AH	1		T50N (standard)
1	567437010000		Lead-acid battery 24V375AH	1		T30N (standard)

Chapter 6: Others

01 Labels and decals (US) (567746047001)

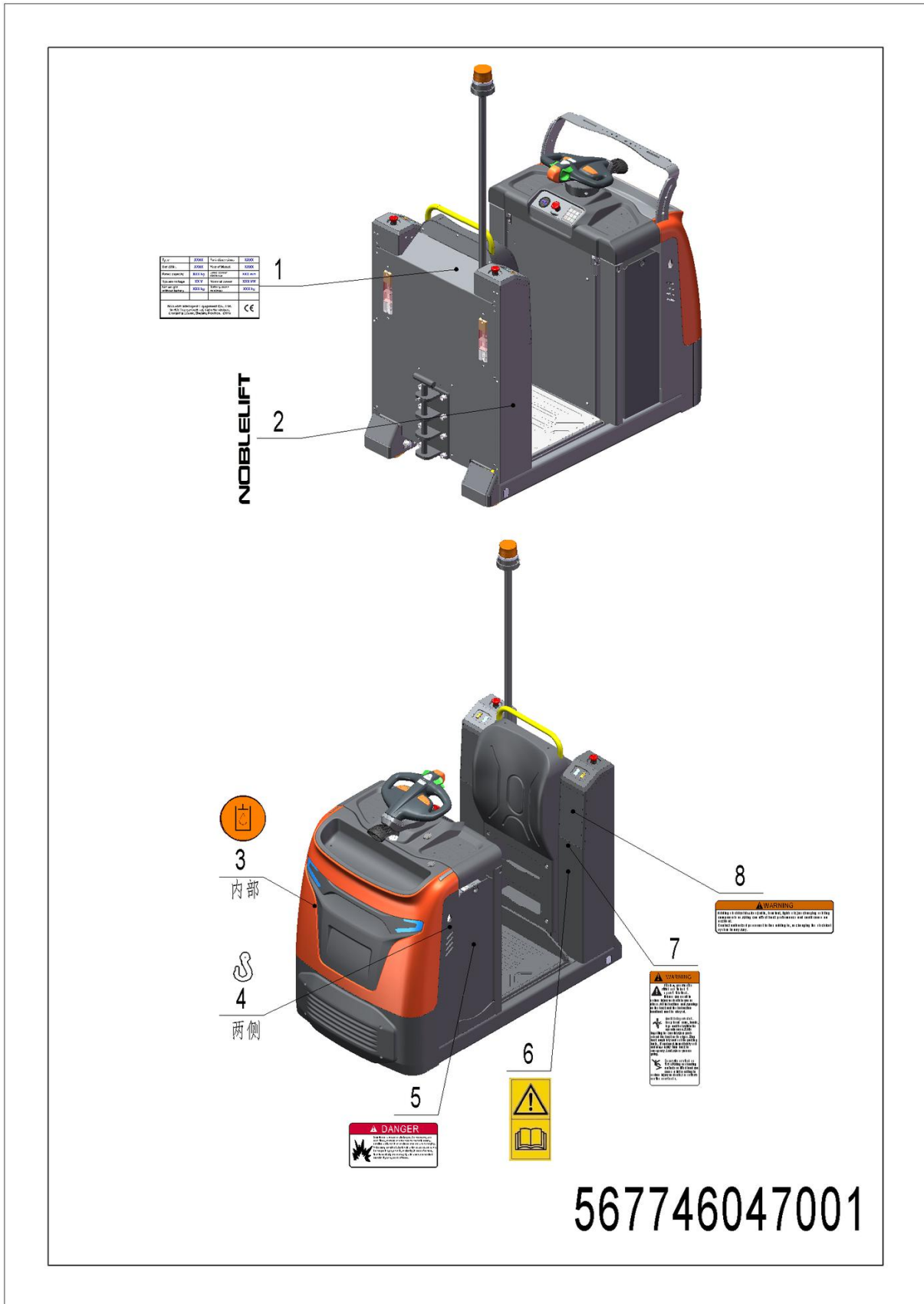

1=Supply as package 2=Supply with limit 3=Phasing out supply 4=Supply as assembly 5=Check other lists

## 01 Labels and decals (US) (567746047001)

No.	Art No.	Mark	Description	Qty.	Substitute No.	Note
1	566547020003		Label (CE mark)	1		
2	941200500001		Label (NOBLELIFT)	2		Optional
3	941200300003		Label (oil filling)	1		
4	941200300001		Label (crane hook )	2		
5	941200100013		Warning label	1		
6	941200300002		Label (read the manual)	1		
7	941200100009		Warning label	1		
8	941200100010		Warning label	1		



02 Labels and decals (EU) (567746047002)

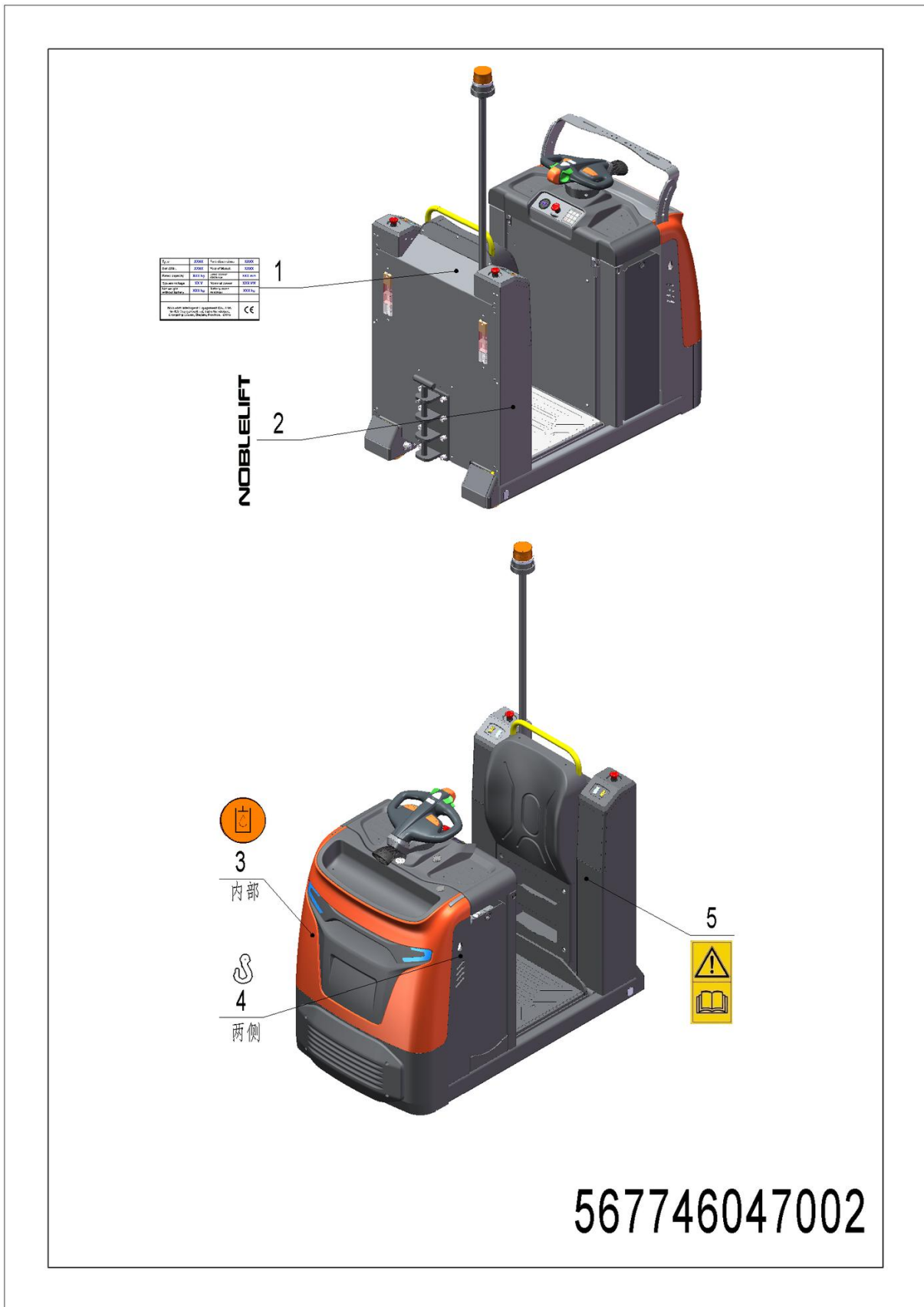

---

**02 Labels and decals (EU) (567746047002)**

No.	Art No.	Mark	Description	Qty.	Substitute No.	Note
1	566547020003		Label (CE mark)	1		
2	941200500001		Label (NOBLELIFT)	2		Optional
3	941200300003		Label (oil filling)	1		
4	941200300001		Label (crane hook)	2		
5	941200300002		Label (read the manual)	1		

Appendix

01 Electrical circuit diagram -T50N Standard

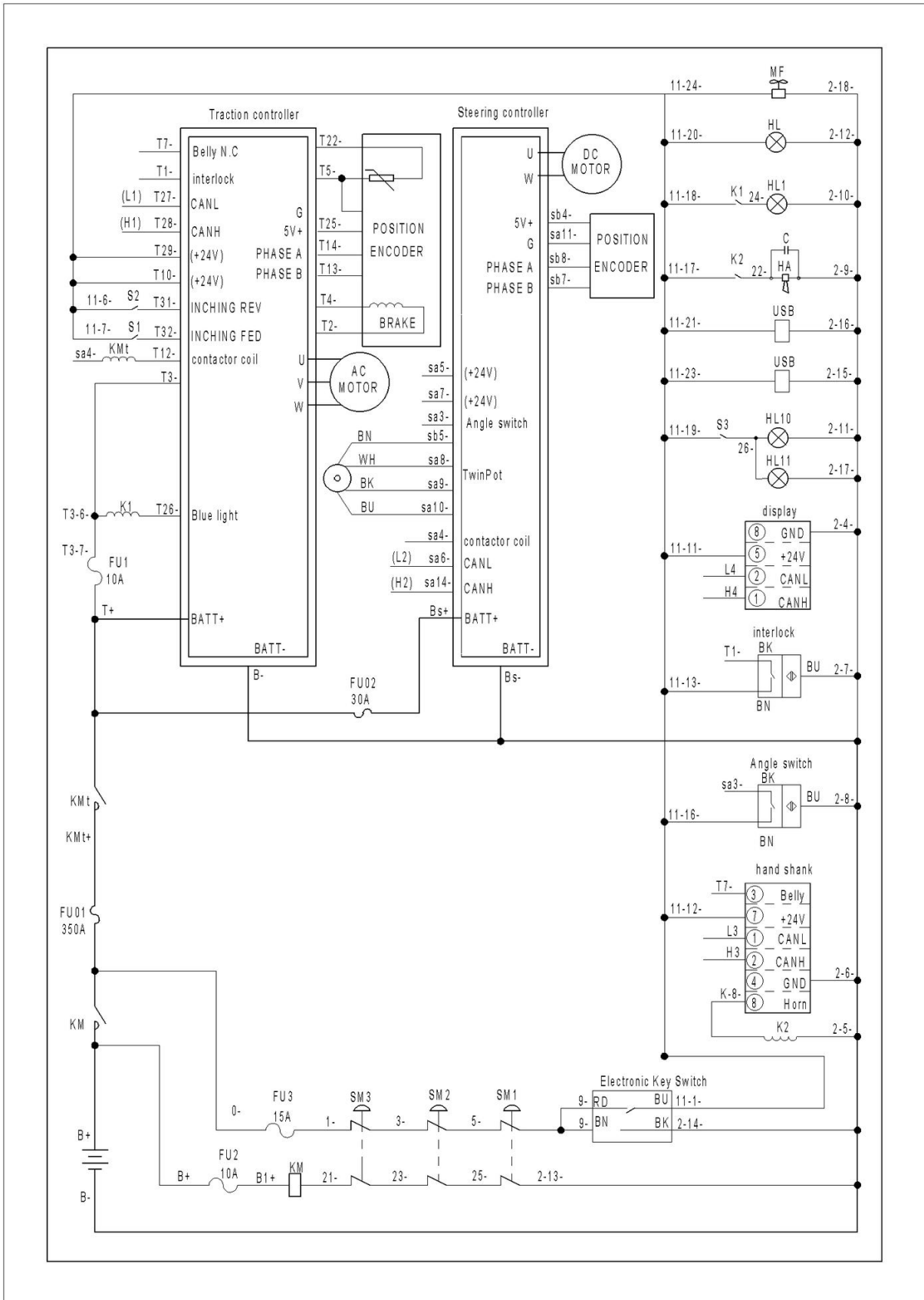

1=Supply as package 2=Supply with limit 3=Phasing out supply 4=Supply as assembly 5=Check other lists

02 Electrical circuit diagram -T50N Optional

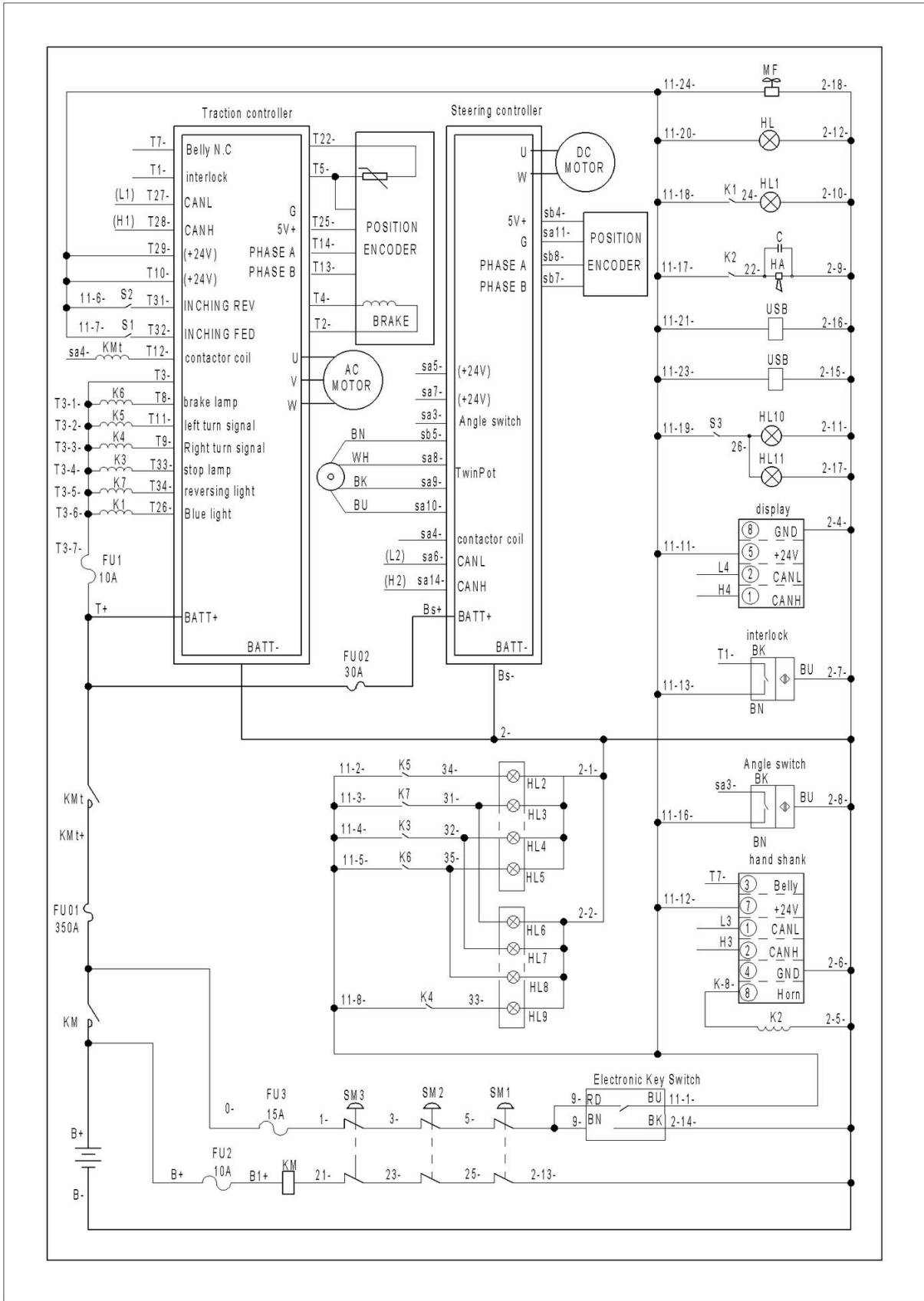

1=Supply as package 2=Supply with limit 3=Phasing out supply 4=Supply as assembly 5=Check other lists

03 Electrical circuit diagram -T30N Standard

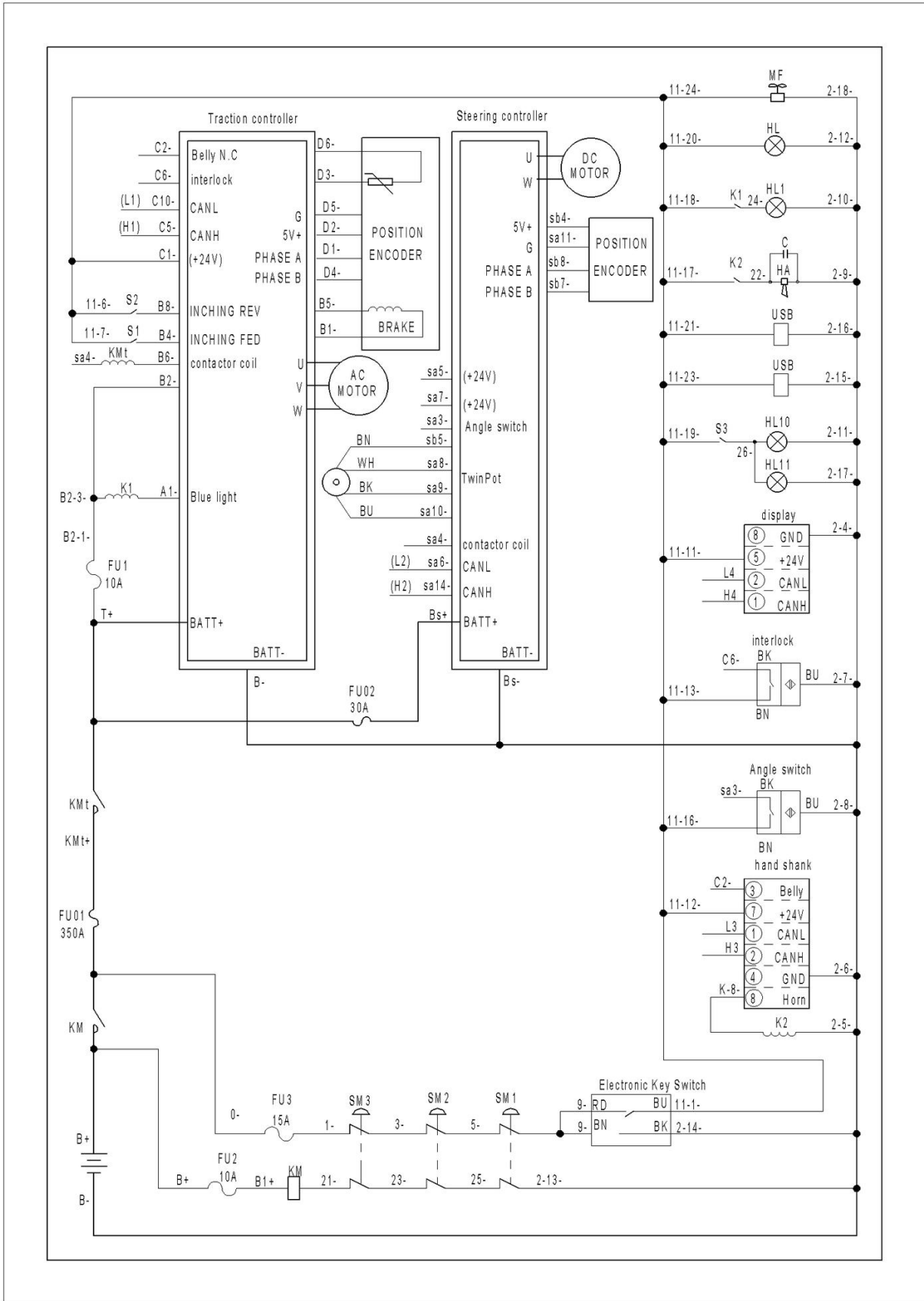

1=Supply as package 2=Supply with limit 3=Phasing out supply 4=Supply as assembly 5=Check other lists

04 Electrical circuit diagram -T30N Optional

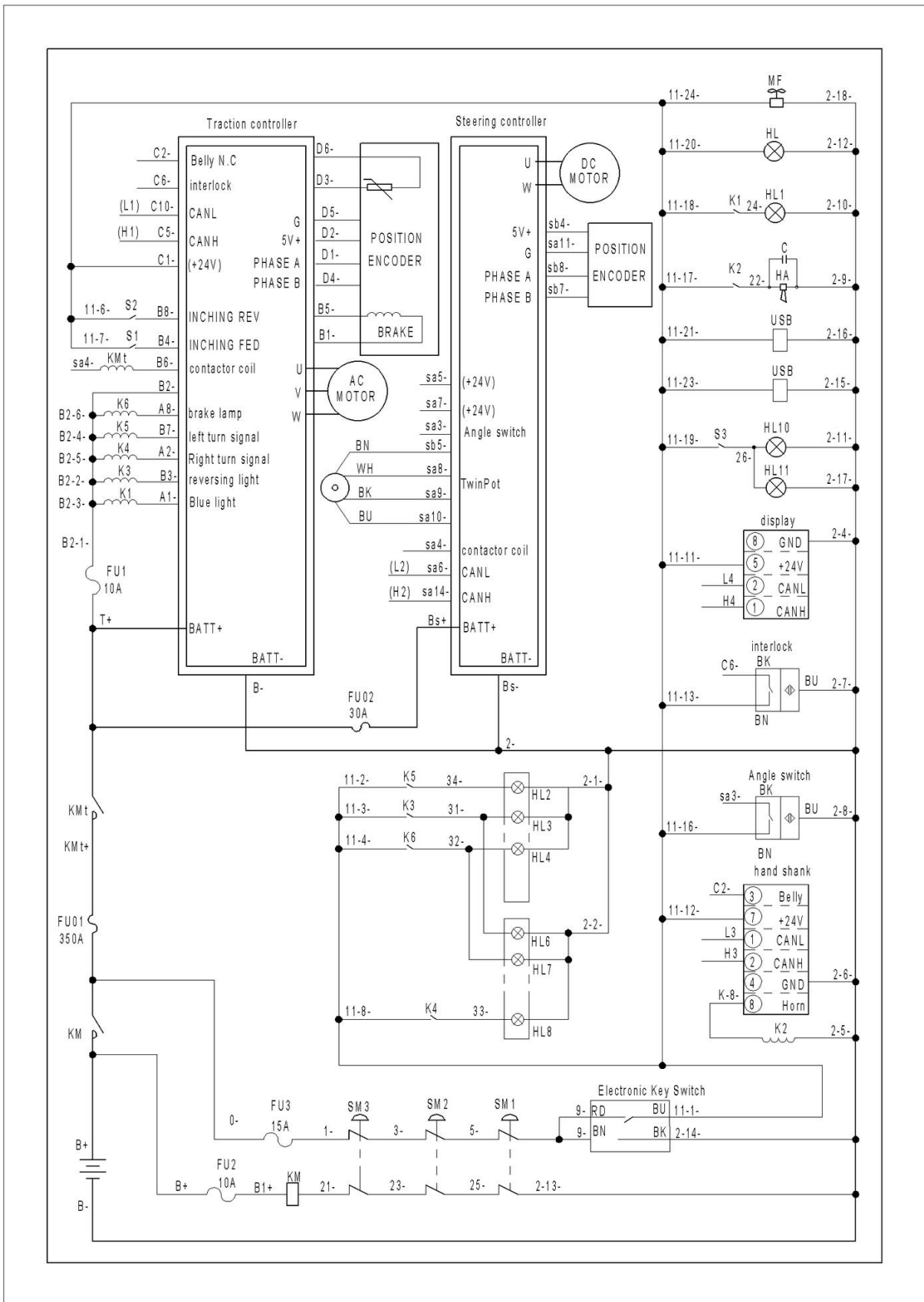

1=Supply as package 2=Supply with limit 3=Phasing out supply 4=Supply as assembly 5=Check other lists

## 05 Easy worn parts list

No.	Art No.	Mark	Description	Qty.	Substitute No.	Note
1	940300400026		Drive wheel (Non-marking) Φ250x80	1		PU
2	940300400019		Drive wheel Φ250x80	1		Rubber
3	940300400027		Drive wheel (Non-marking) Φ230x70	1		PU
4	940300400020		Drive wheel Φ230x70	1		Rubber
5	566521520082		Rubber plug (left)	1		
6	566521520083		Rubber plug (right)	1		
7	921900100004		Converter DC (24V to 5V)	1		
8	920200300001		Microswitch XZ-15GW22-B			
9	502311010001		Proximity switch NBN5-F7-E2 (80mm)	1		
10	940500200018		Bushing Φ16xΦ18x12	2		
11	566518020031		Left torsion spring Φ22xΦ4x50	1		
12	566518020032		Right torsion spring Φ22xΦ4x50	1		
13	566518020086		Cushion plug M8x54	2		
14	940400500004		Spring Φ40xΦ5x55	2		
15	566518020033		Cushion washer Φ30xΦ13x31	2		
16	566518020088		Damper	2		
17	940801000001		Pin with loop	1		
18	922000100003		Tri-color taillight	2		
19	910700600001		Bearing GB297-30205	2		
20	567798510002		Wheel assembly	1		
21	505616520000		Spring(PU)	1		
22	940400500007		Spring Φ43xΦ9x62	1		
23	567798510003		Wheel assembly	2		
24	566518010011		Lock catch M12x100	1		
25	566531520006		Spring Φ70xΦ3.5x37	1		
26	566531520004		Axle sleeve	2		
27	566531520005		Sleeve (PA)	1		
28	565931520005		Connection block	1		
29	921800200006		Potentiometer RPAZ052	1		
30	231033010020		Beacon wire harness (light)	1		
31	231033010021		Beacon wire harness (light and sound)	1		Optional
32	920100100013		Fuse 350A	1		
33	920100100001		Fuse 30A	1		
34	920100200003		Fuse 15A	1		
35	920100200002		Fuse 10A	1		