

# SPAREPARTS LIST

## Electric Stacker PS 44L

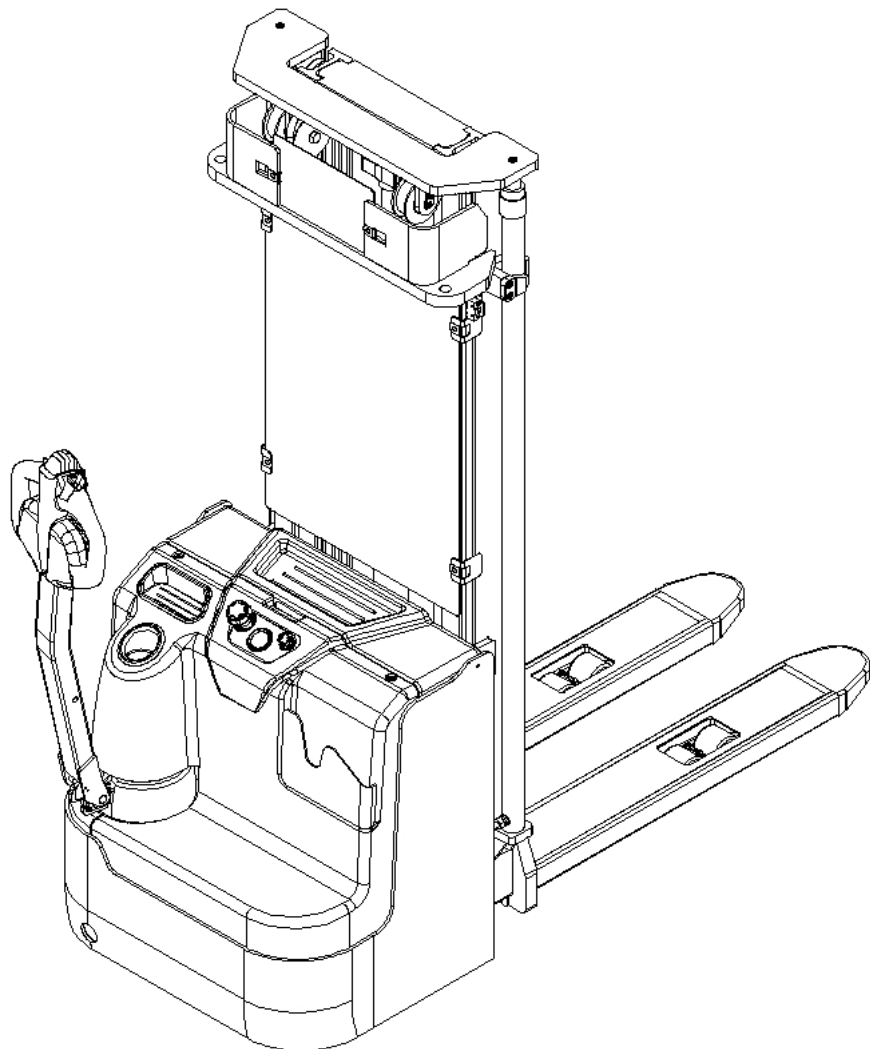

Version 02/2016

From truck identification number:

PS 20L-BPT-002-EN

# Catalogue

Fig.1 Label (For EU).....	1
Fig.2 Label (For US).....	2
Fig.3 Outline.....	3
Fig.4 Pallet.....	4
Fig.5 Fork assembly (straddle).....	5
Fig.6 Truck assembly.....	6
Fig.7 Truck assembly(Side pull battery).....	8
Fig.8 Truck assembly (straddle).....	10
Fig.9 Power supply.....	12
Fig.10 Instrument assembly.....	13
Fig.11 Battery cover assembly.....	15
Fig.12 Steering wheel assembly.....	16
Fig.13 Three-stage mast system (full free lift).....	17
Fig.14 Three-stage mast system(standard lift).....	18
Fig.15 Two-stage mast system(full free lift).....	19
Fig.16 Two-stage mast system(standard lift).....	20
Fig.17 Three-stage mast chain system(full free lift).....	21
Fig.18 Three-stage mast chain system(standard lift).....	23
Fig.19 Two-stage mast chain system(full free lift).....	24
Fig.20 Two-stage mast chain system(standard lift).....	26
Fig.21 Mast and other parts.....	27
Fig.22 Three-stage mast hydraulic system(full free lift).....	28
Fig.23 Three-stage mast hydraulic system(standard lift).....	30
Fig.24 Two-stage mast hydraulic system(full free lift).....	32
Fig.25 Two-stage mast hydraulic system(standard lift).....	34
Fig.26 Three-stage mast outer cylinder assembly(full free lift).....	36
Fig.27 Three-stage mast middle cylinder assembly(full free lift).....	38
Fig.28 Three-stage mast outer cylinder assembly(standard lift).....	40
Fig.29 Two-stage mast outer cylinder assembly(full free lift).....	42
Fig.30 Two-stage mast middle cylinder assembly(full free lift).....	44
Fig.31 Two-stage mast outer cylinder assembly(standard lift).....	46
Fig.32 Drive system assembly.....	48
Fig.33 Load wheel assembly.....	49

Fig.34 Handle assembly .....	51
Fig.35 Pump system.....	52
Fig.36 Main circuit harness.....	53
Fig.37 Electrical general part.....	54
Fig.38 Controller assembly.....	55
Fig.39 Load backrest .....	57
Fig.40 Load backrest (straddle).....	58
Easy worn parts list .....	59

Fig.1 Label (For EU)

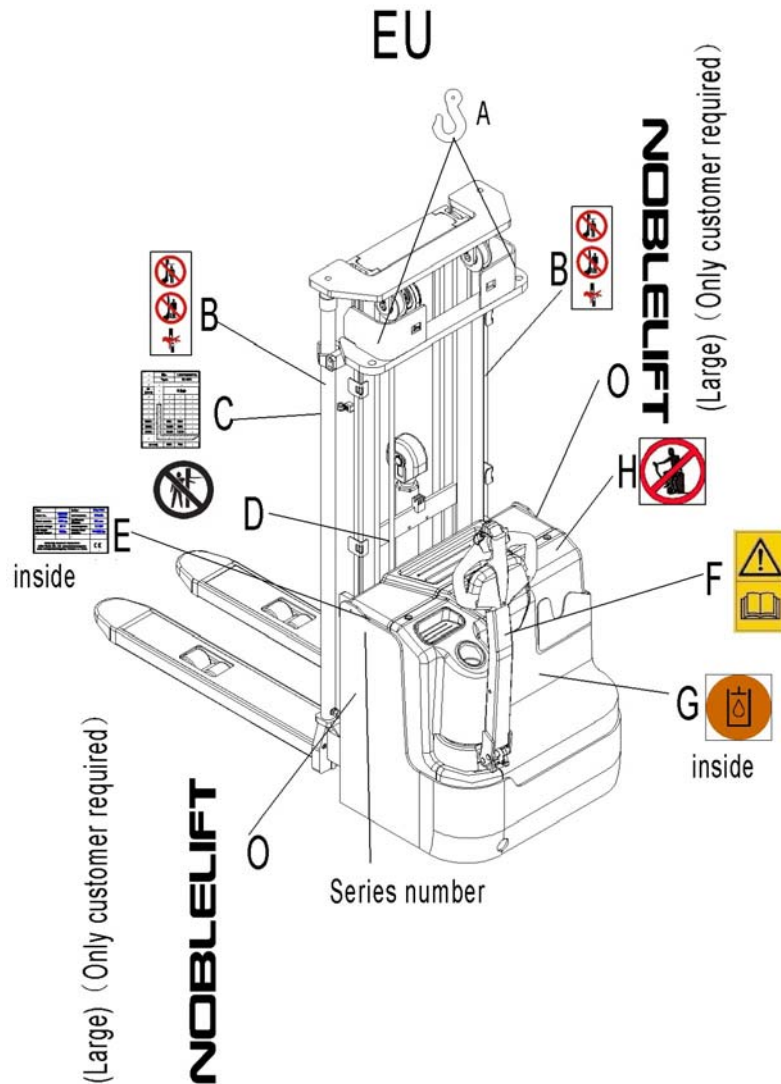

Fig.1 Label (For EU)

No.	Art No.	Description	Qty.	Note
A	9000005967	Crane hook label	2	
B	9000003923	Warning decal: Do not step under or on the forks	2	
C	9000016325	Residual lift capacity sticker	1	
D	9000008561	Never reach through	1	
E	9000016326	CE label	1	
F	9000003570	Sticker to read and follow these instructions	1	
G	9000008555	Filling sticker	1	
H	9000003573	'No passengers' decal	1	
O	9000008556	Emblem mark	2	

Fig.2 Label (For US)

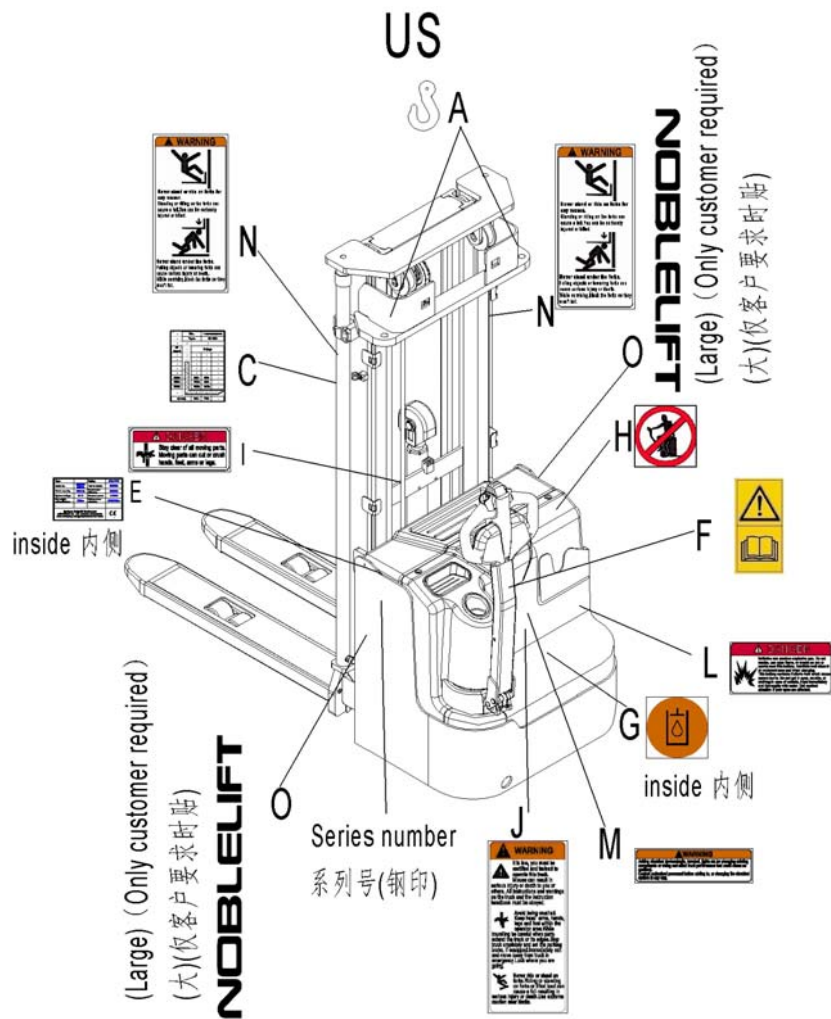
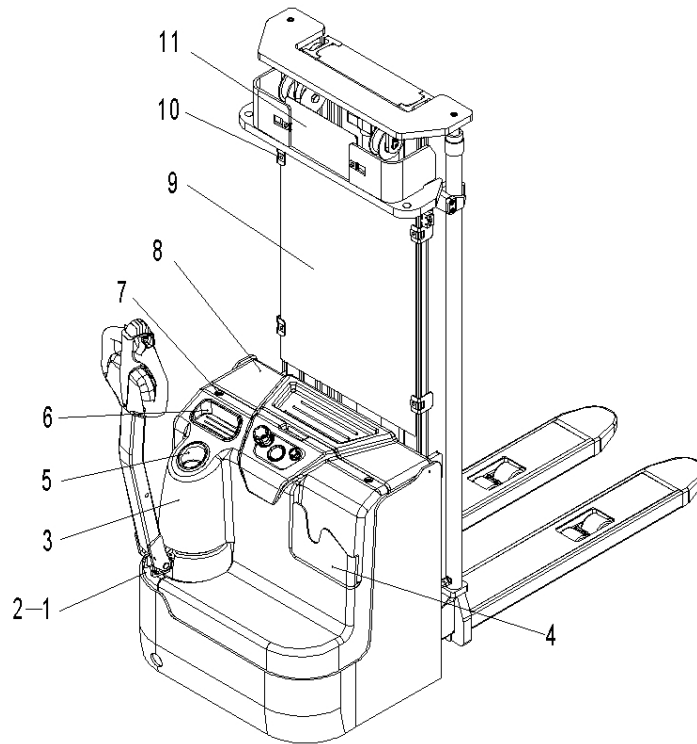

Fig.2 Label (For US)

No.	Art No.	Description	Qty.	Note
A	9000005967	Crane hook label	2	
C	9000016325	Residual lift capacity sticker	1	
E	9000016326	CE label	1	
F	9000003570	Sticker to read and follow these instructions	1	
G	9000008555	Filling sticker	1	
I	9000005970	Warning label	1	
J	9000003575	Warning label	1	
K	9000003580	Warning label	1	
L	9000003577	Warning label	1	
M	9000003579	Warning label	1	
N	9000005971	Warning label	2	

**Fig.3 Outline**



**Fig.3 Outline**

No.	Art No.	Description	Qty.	Note
1	9000015364	Cover	1	
2	0000023093	Lock screw	2	M6x10
3	9000015363	Electrical box cover	1	
4	9000010660	File box	1	
5	9000015365	Cup base	1	
6	9000015366	Storage box	1	
7	9000007790	Screw	2	M10x55
8	9000015946	Battery cover	1	
9	9000015914	Protective plate	1	(4600)
	9000015934	Protective plate	1	(4300)
	9000015977	Protective plate	1	(4000)
	9000015798	Protective plate	1	(3600)
	9000015801	Protective plate	1	(3200)
	9000015808	Protective plate	1	(2900)
9000015858	Protective plate	1	(2700)	
10	9000007782	Spring buckle	6	(thickness 1)
11	9000015913	Upper protective plate	1	

**Fig.4 Pallet**

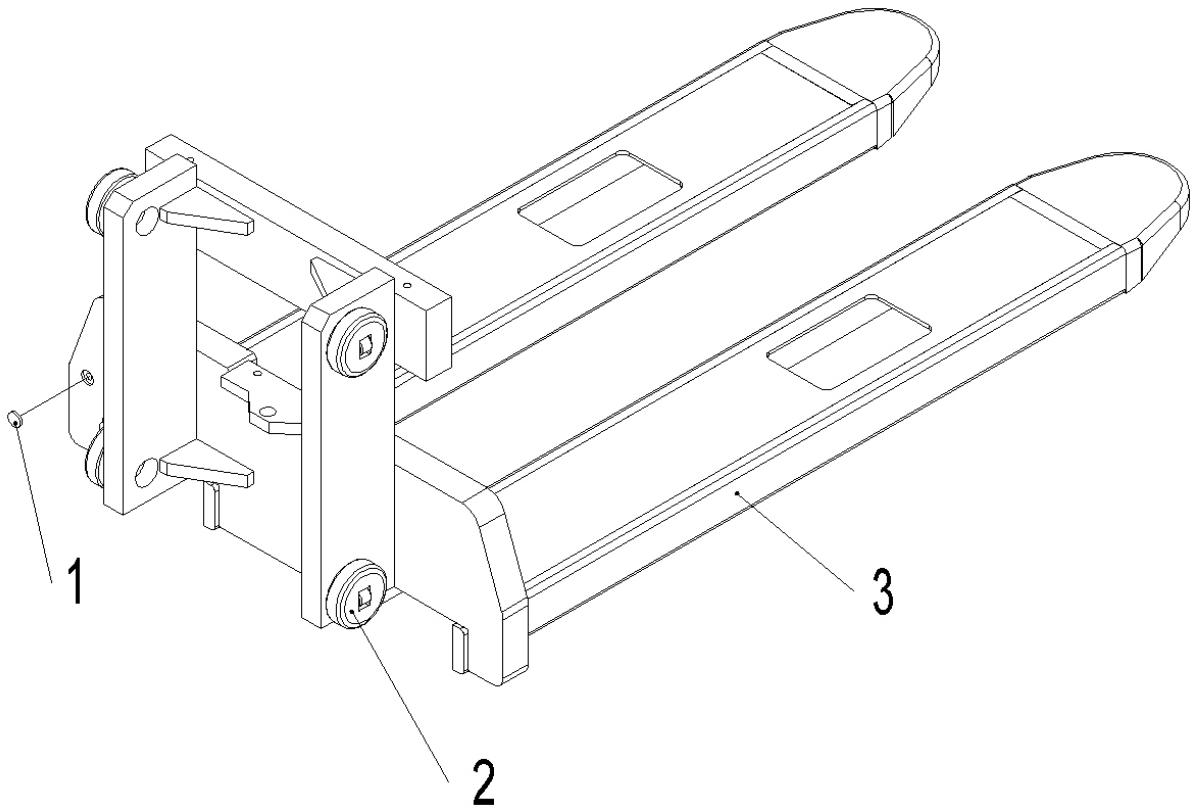

**Fig.4 Pallet**

No.	Art No.	Description	Qty.	Note
1	2000435002	Magnet steel	1	
2	3500100004	Roller	4	1
3	9000015811	Pallet (570×1150)	1	Two-stage mast
	9000015819	Pallet (685×1150)	1	Two-stage mast
	9000015937	Pallet (570×1150)	1	Three-stage mast
	9000015953	Pallet (685×1150)	1	Three-stage mast

**Fig.5 Fork assembly (straddle)**

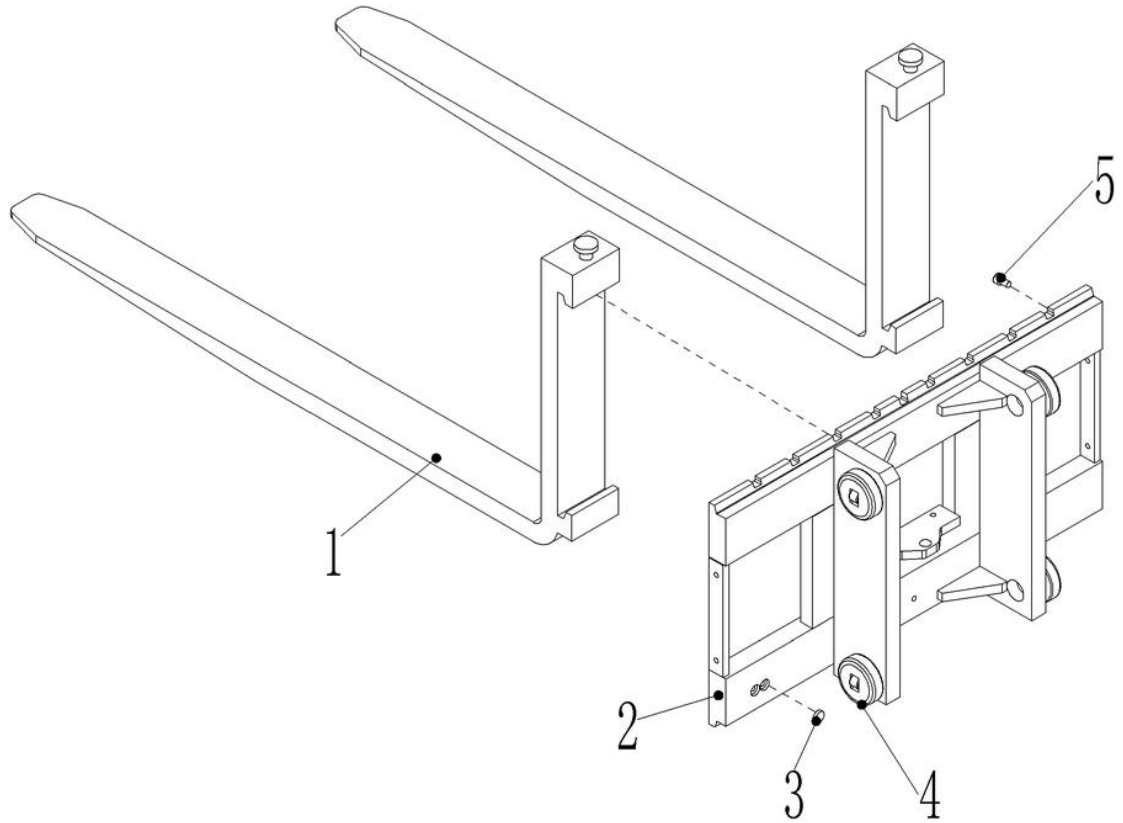
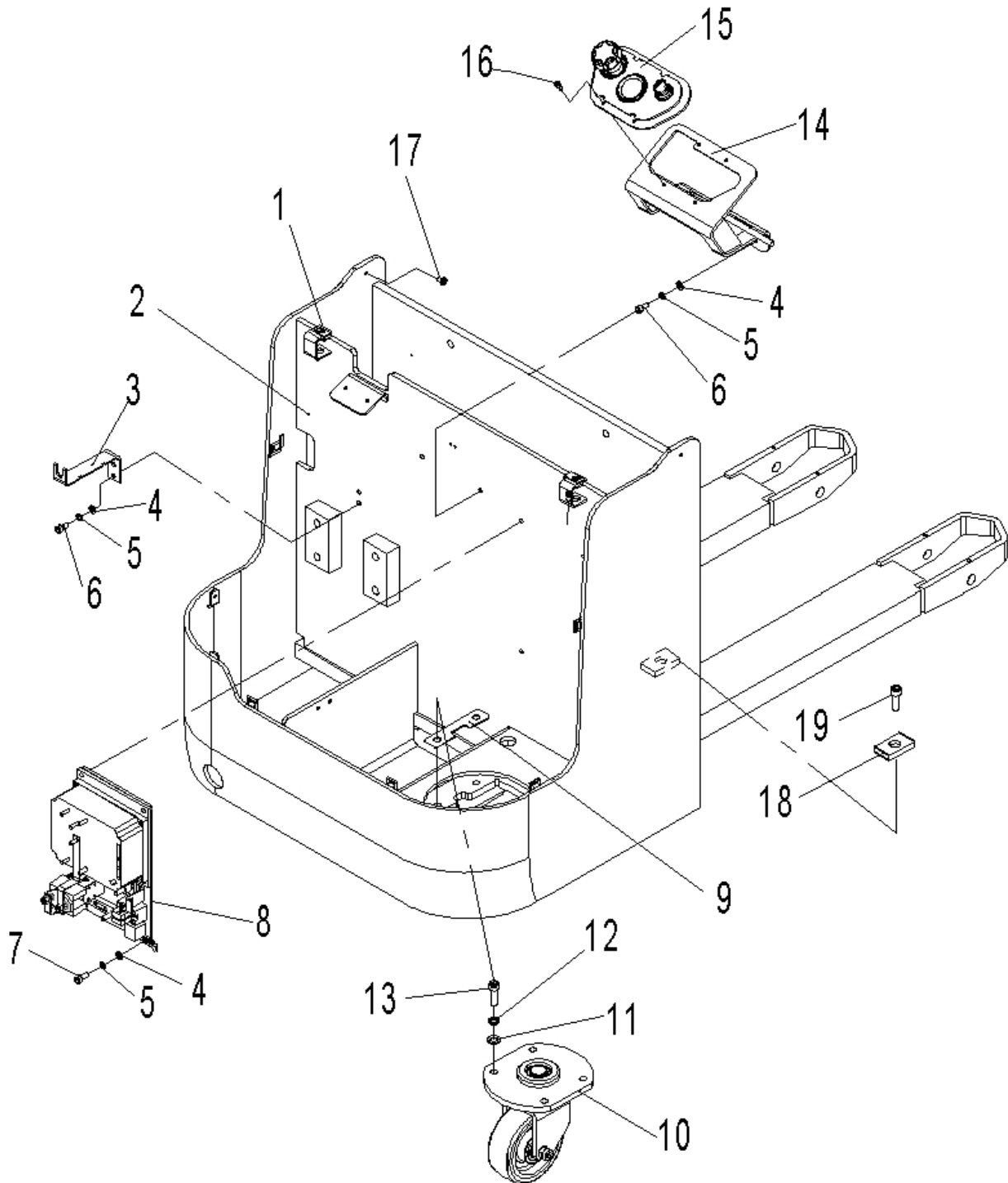

**Fig.5 Fork assembly (straddle)**

No.	Art No.	Description	Qty.	Note
1	9000017399	Fork assembly (hook type)	2	Width: 120
2	9000016314	Fork frame assembly	1	Three-stage-mast
	9000016310			Two-stage-mast
3	2000435002	Magnet steel	1	
4	3500100004	Roller 1	4	
5	0000023080	Screw	2	M10x16



Fig.6 Truck assembly



**Fig.6 Truck Assembly**

No.	Art No.	Description	Qty.	Note
1	9000007783	Nut	2	M10
2	9000015945	Truck body	1	570x1150
	9000015960	Truck body	1	685x1150
3	9000015356	Cable holder	1	
4	0000025011	Washer	8	8
5	0000025001	Washer	8	8
6	0000023067	Screw	4	M8x16
7	0000023061	Screw	4	M8x25
8	9000015362	Controller fixing plate	1	
9	9000015361	Steering wheel pad	6	
10	9000015432	Steering wheel assembly	1	
11	0000025032	Washer	4	12
12	0000025024	Washer	4	12
13	0000023082	Screw	4	M12x35
14	9000015430	Fixing plate	1	
15	9000015431	Instrument assembly	1	
16	0000023020	Screw	4	M6x20
17	9000015369	Locating sleeve	2	
18	9000015373	Cushion	2	
19	0000023045	Screw	2	M6x12

**Fig.7 Truck assembly(side pull battery)**

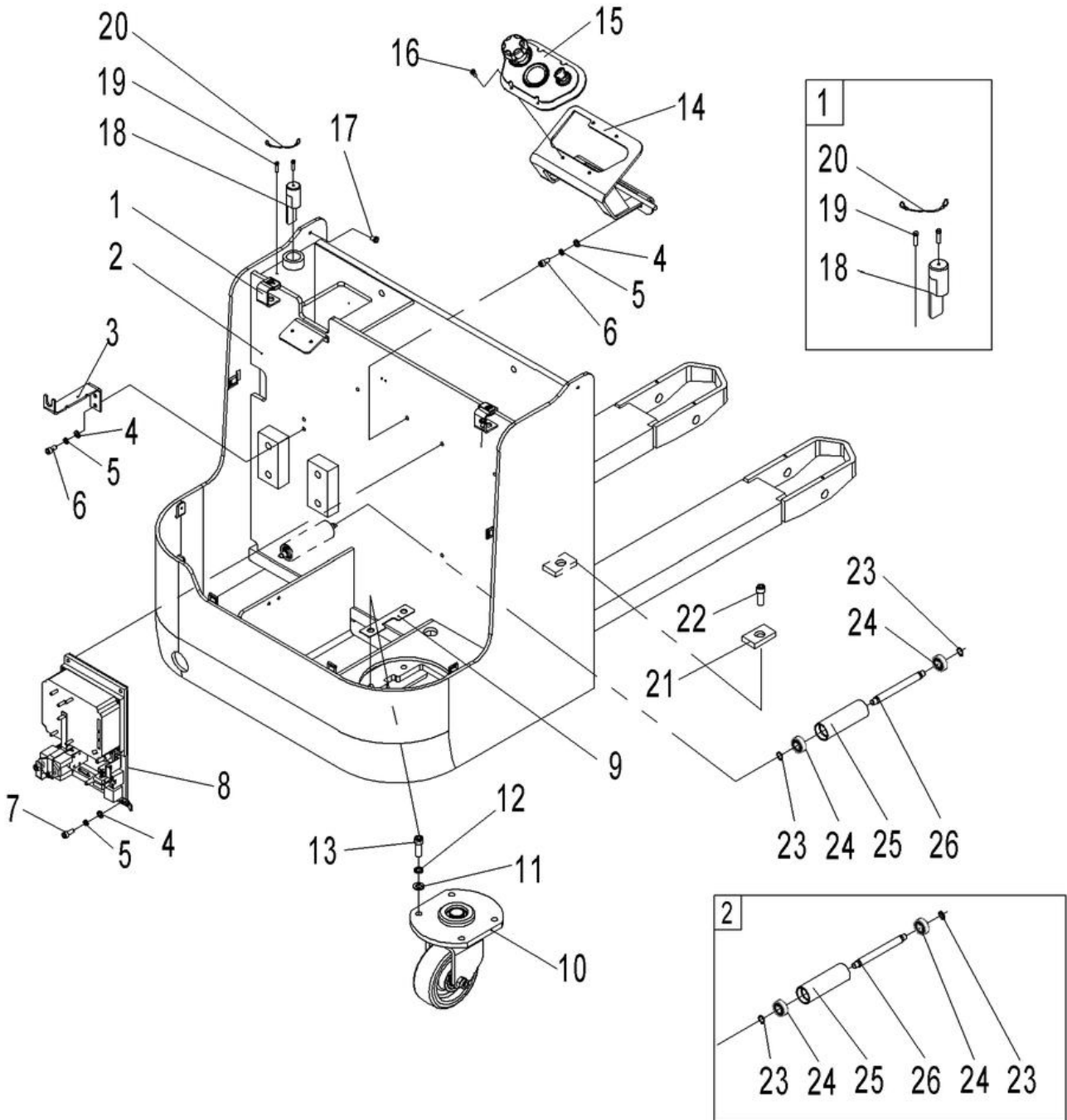

**Fig.7 Truck Assembly(side pull battery)**

No.	Art No.	Description	Qty.	Note
1	9000007783	Nut	2	M10
2	9000017419	Truck body	1	570x1150
	9000017425	Truck body	1	685x1150
3	9000015356	Cable holder	1	
4	0000025011	Washer	8	8
5	0000025001	Washer	8	8
6	0000023067	Screw	4	M8x16
7	0000023061	Screw	4	M8x25
8	9000015362	Controller fixing plate	1	
9	9000015361	Steering wheel pad	6	
10	9000015432	Steering wheel assembly	1	
11	0000025032	Washer	4	12
12	0000025024	Washer	4	12
13	0000023082	Screw	4	M12x35
14	9000015430	Fixing plate	1	
15	9000015431	Instrument assembly	1	
16	0000023020	Screw	4	M6x20
17	9000015369	Locating sleeve	2	
18	9000017412	Lock shaft	1	
19	9000017413	Short connecting rod	2	
20	9000017414	Wirerope	1	
21	9000015373	Cushion	2	
22	0000023045	Screw	2	M6x12
23	0000026004	Circlip	12	15
24	0000027060	Bearing	12	6202
25	9000017410	Barrel	6	
26	9000017409	Axle	6	
[1]	9000017411	Lock shaft assembly	1	
[2]	9000017408	Roller assembly	6	

**Fig.8 Truck assembly (straddle)**

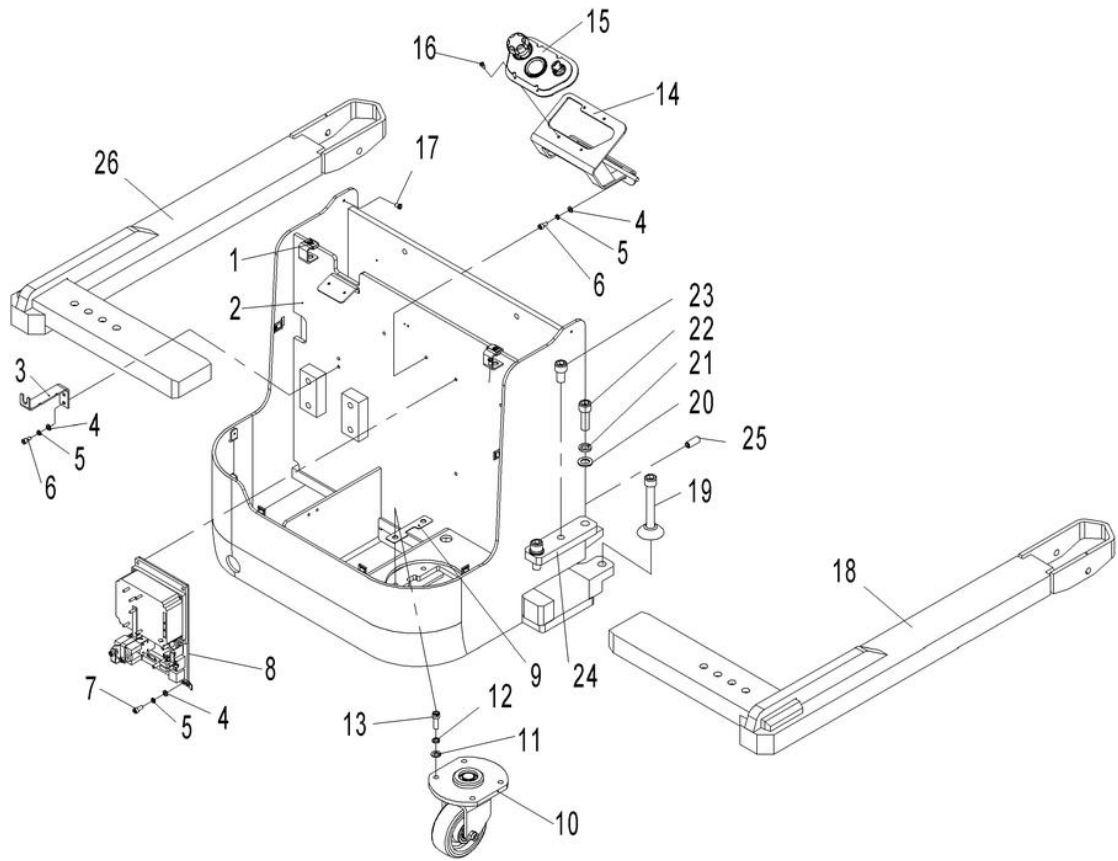

**Fig.7 Truck assembly (straddle)**

No.	Art No.	Description	Qty.	Note
1	9000007783	Nut	2	M10
2	9000016317	Truck assembly	1	
3	9000015356	Cable holder	1	
4	0000025011	Washer	8	8
5	0000025001	Spring washer	8	8
6	0000023067	Screw	4	M8x16
7	0000023061	Screw	4	M8x25
8	9000015362	Controller fixing plate	1	
9	9000015361	Steering wheel pad	6	
10	9000015432	Steering wheel	1	
11	0000025032	Washer	4	12
12	0000025024	Spring washer	4	12
13	0000023082	Screw	4	M12x35
14	9000015430	Fixing plate	1	
15	9000015431	Instrument	1	
16	0000023020	Screw	4	M6x20
17	9000015369	Locating sleeve	2	
18	9000016303	Right front leg	1	
19	2050402002	Supporting assembly	2	
20	0000025031	Washer	4	20
21	0000025033	Spring washer	4	20
22	0000023453	Screw	4	M20x60
23	2050402003	Locating pin	2	
24	9000016290	Pressure plate	2	
25	0090000758	Lock screw	6	M16x40
26	9000016301	Left front leg	1	

**Fig.9 Power supply**

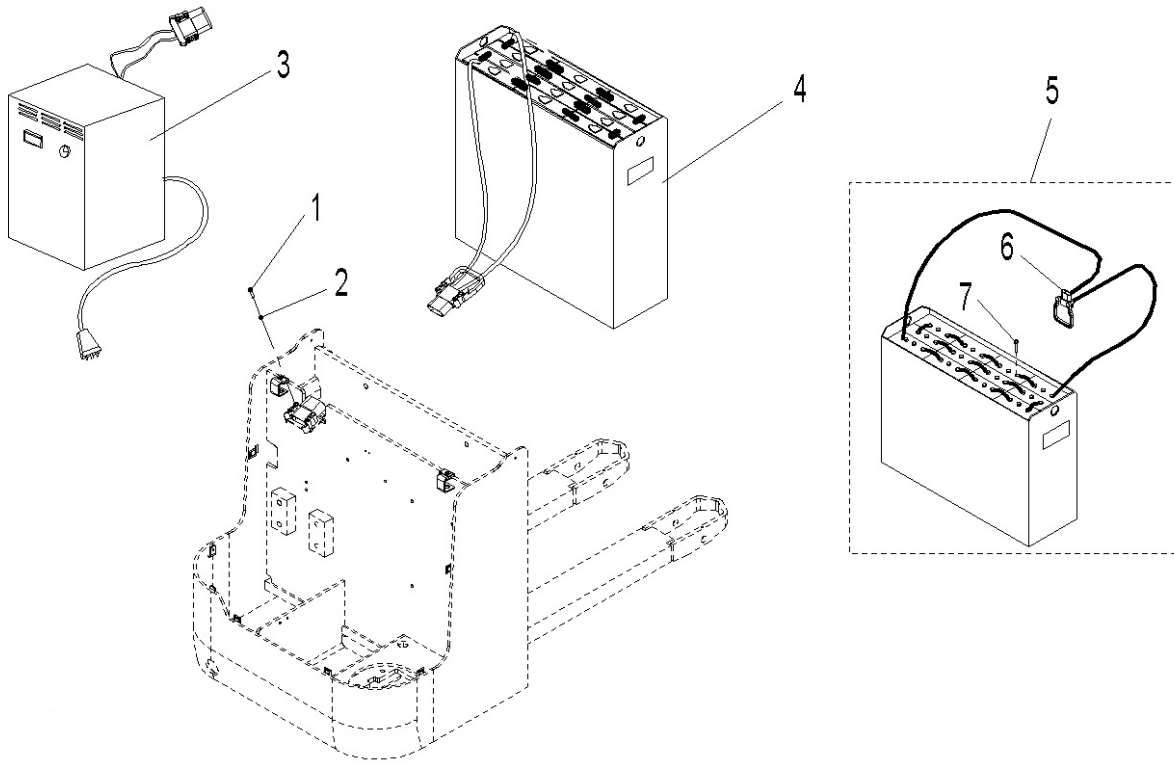

**Fig.8 Power supply**

No.	Art No.	Description	Qty.	Note
1	0000023106	Screw	2	M6×30
2	0000023055	Washer	2	6
3	9000010147	Charger (Asian in Chinese)	1	24V/45A
	9000010148	Charger (Asian in English)		24V/45A
	9000010194	Charger (European)		24V/45A
	9000010195	Charger (Australian)		24V/45A
	9000010196	Charger (British)		24V/45A
	9000010197	Charger (American)		24V/45A
4	9000008322	Power assembly-welded	1	(350Ah)
5	9000009835	Power assembly-bolted	1	(350Ah)
6	2000434002	Connector assembly	1	Only for bolt type battery
7	9000009832	Screw M10X22	24	

Fig.10 Instrument assembly

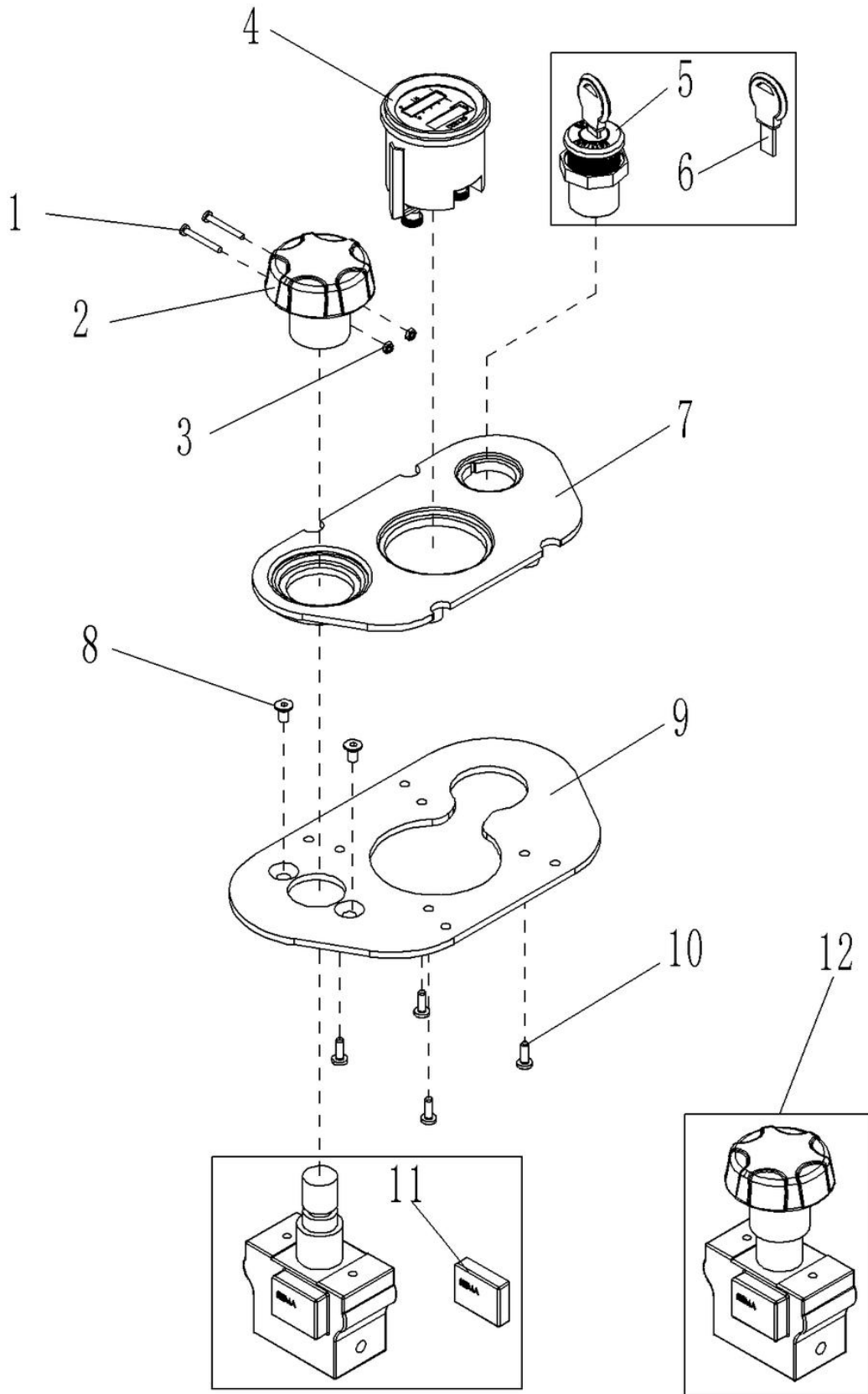
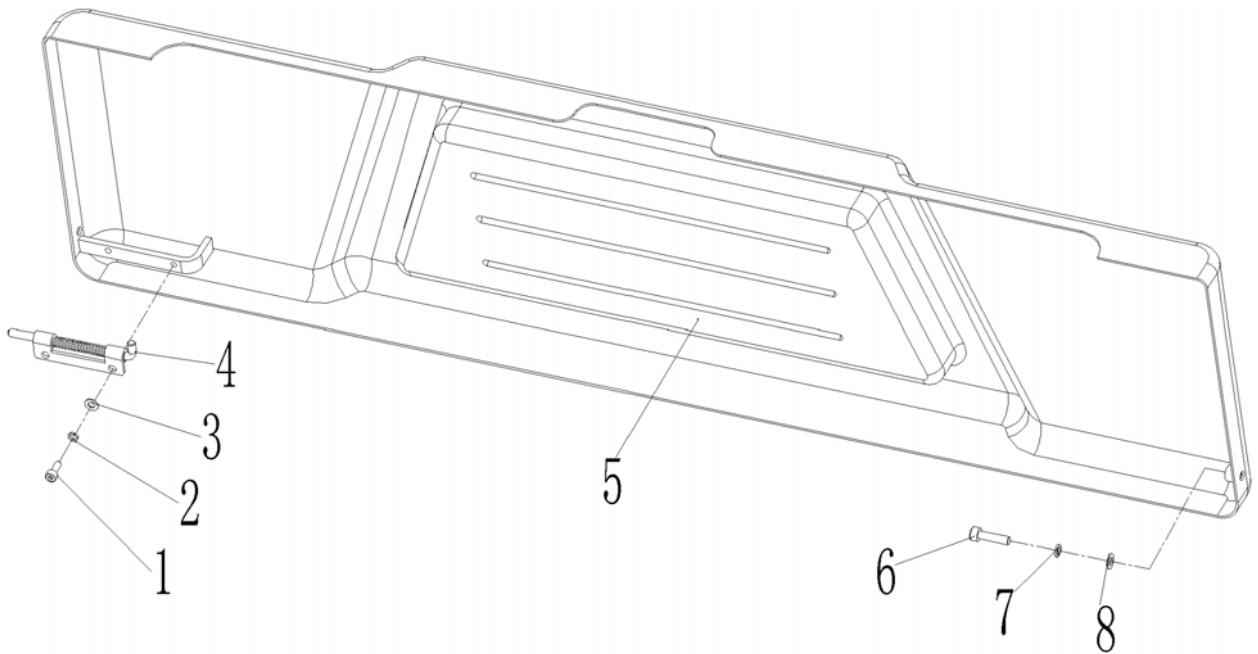



**Fig.9 Instrument Assembly**

No.	Art No.	Description	Qty.	Note
1	0000023685	Screw	2	M3×25
2	9000008516	DC power switch-mushroom cap	1	ZDK32-350
3	0000024002	Nut	2	M3
4	9000000760	Indicator	1	MDI CAN
5	9000008326	Key switch	1	LKS-101A
6	9000008519	Key switch-key	1	LKS-101A
7	9000015354	Integrated leaf panel	1	
8	0000023215	Screw	2	M5×10
9	9000015355	Instrument fixing plate	1	
10	0090000272	Lock screw	4	M4×12
11	9000008517	Micro switch	1	ZDK32-350
12	9000008515	DC power switch	1	ZDK32-350

**Fig.11 Battery cover assembly**



**Fig.10 Battery Cover Assembly**

No.	Art No.	Description	Qty.	Note
1	0000023073	Screw	2	M4×10
2	0000025018	Washer	2	4
3	0000025019	Washer	2	4
4	9000008795	Latch	1	
5	9000015947	Battery cover	1	
6	0000023306	Screw	1	M5×20
7	0000025015	Washer	1	5
8	0000025014	Washer	1	5

**Fig.12 Steering wheel assembly**

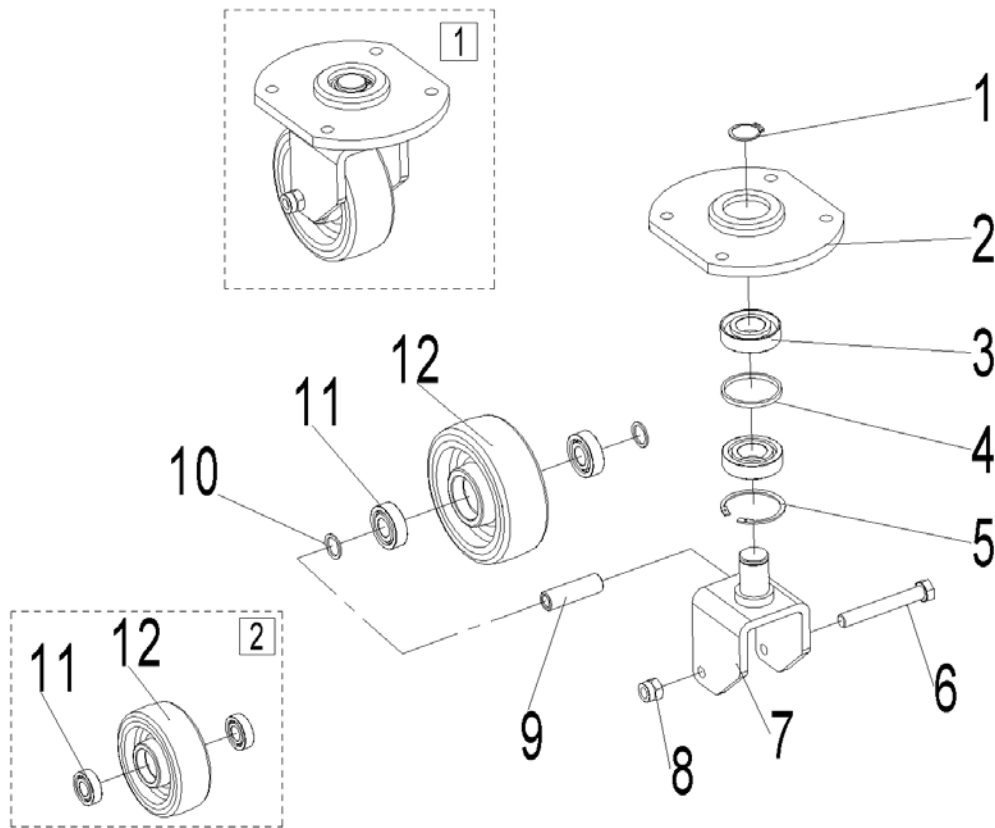

**Fig.11 Steering Wheel Assembly**

No.	Art No.	Description	Qty.	Note
1	0000026008	Circlip	1	30
2	9000015433	Bearing seat	1	
3	0000027013	Bearing	2	7206C/DB
4	2000413001	Bushing	1	
5	0000026010	Circlip	1	62
6	0000023111	Bolt	1	M14x100
7	9000015434	Rear wheel carrier	1	
8	0000024015	Lock nut	1	M14
9	2000413002	Bushing	1	
10	1000525001	Washer	2	
11	0000027001	Bearing	2	6204
12	2210416001	Rear wheel	1	
1	9000015432	Steering wheel assembly	1	
2	9000008896	Wheels	1	

**Fig.13 Three-stage mast system (full free lift)**

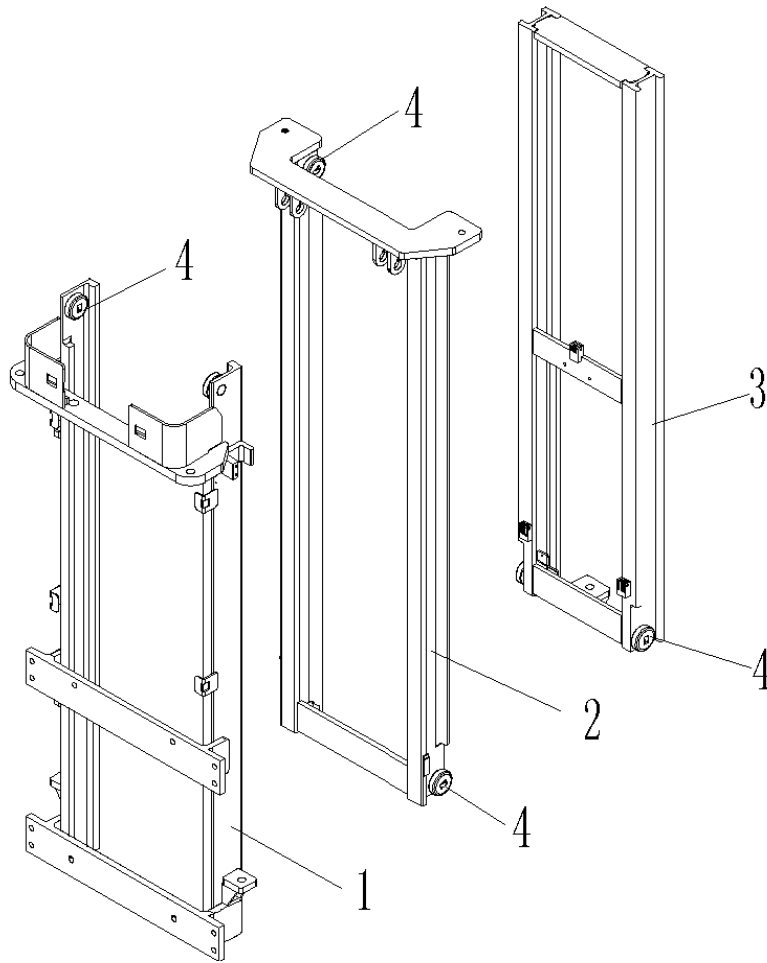

**Fig.12 Three-stage Mast System(full free lift)**

No.	Art No.	Description	Qty.	Note
1	9000015981	Mast	1	4600
	9000015988	Mast	1	4300
	9000015993	Mast	1	4000
2	9000015983	Mast	1	4600
	9000015989	Mast	1	4300
	9000015994	Mast	1	4000
3	9000015984	Mast	1	4600
	9000015990	Mast	1	4300
	9000015995	Mast	1	4000
4	3500100004	Roller	8	

**Fig.14 Three-stage mast system(standard lift)**

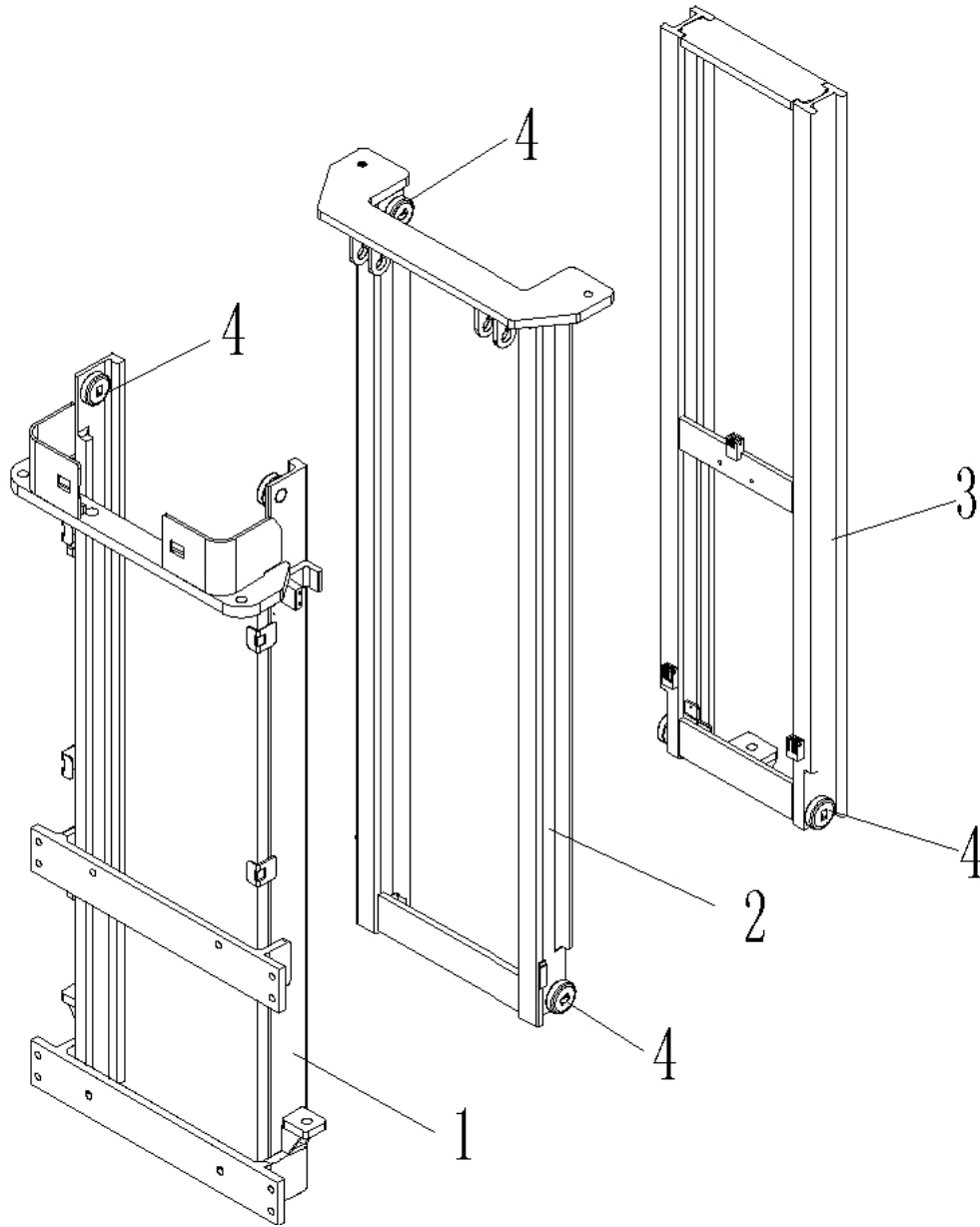

**Fig.13 Three-stage Mast System(standard lift)**

No.	Art No.	Description	Qty.	Note
1	9000015939	Mast	1	4600
	9000015955	Mast	1	4300
2	9000015940	Mast	1	4600
	9000015956	Mast	1	4300
3	9000015941	Mast	1	4600
	9000015957	Mast		4300
4	3500100004	Roller	8	1

**Fig.15 Two-stage mast system(full free lift)**

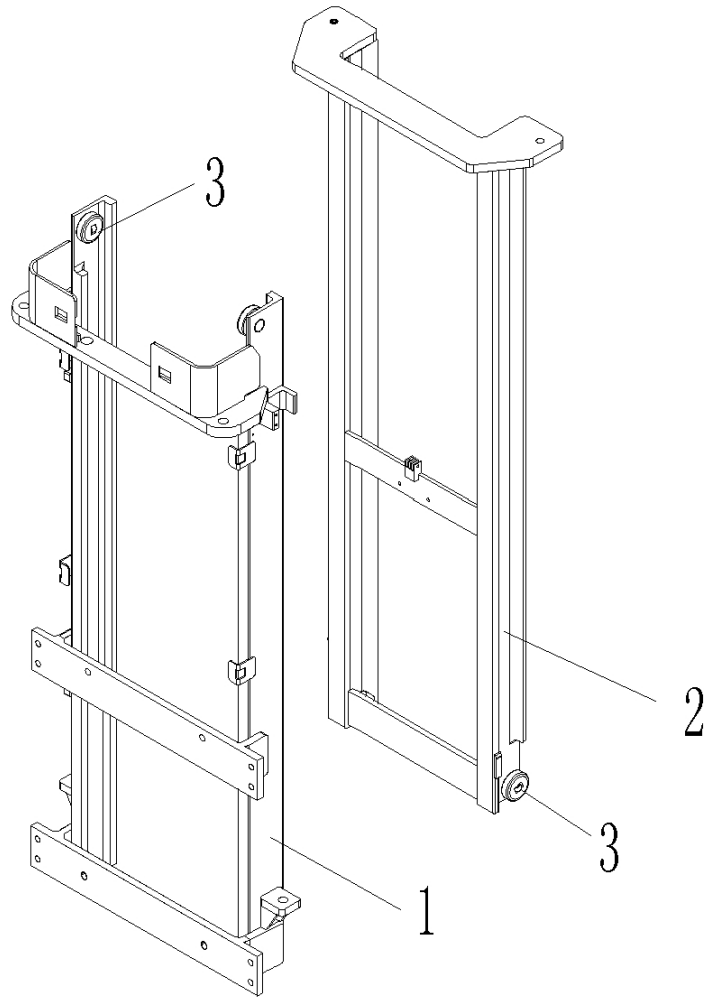

**Fig.14 Two-stage Mast System(full free lift)**

No.	Art No.	Description	Qty.	Note
1	9000015863	Mast	1	3600
	9000015869	Mast	1	3200
	9000015874	Mast	1	2900
	9000015879	Mast	1	2700
2	9000015864	Mast	1	3600
	9000015870	Mast	1	3200
	9000015875	Mast	1	2900
	9000015880	Mast	1	2700
3	3500100004	Roller	4	1

**Fig.16 Two-stage mast system(standard lift)**

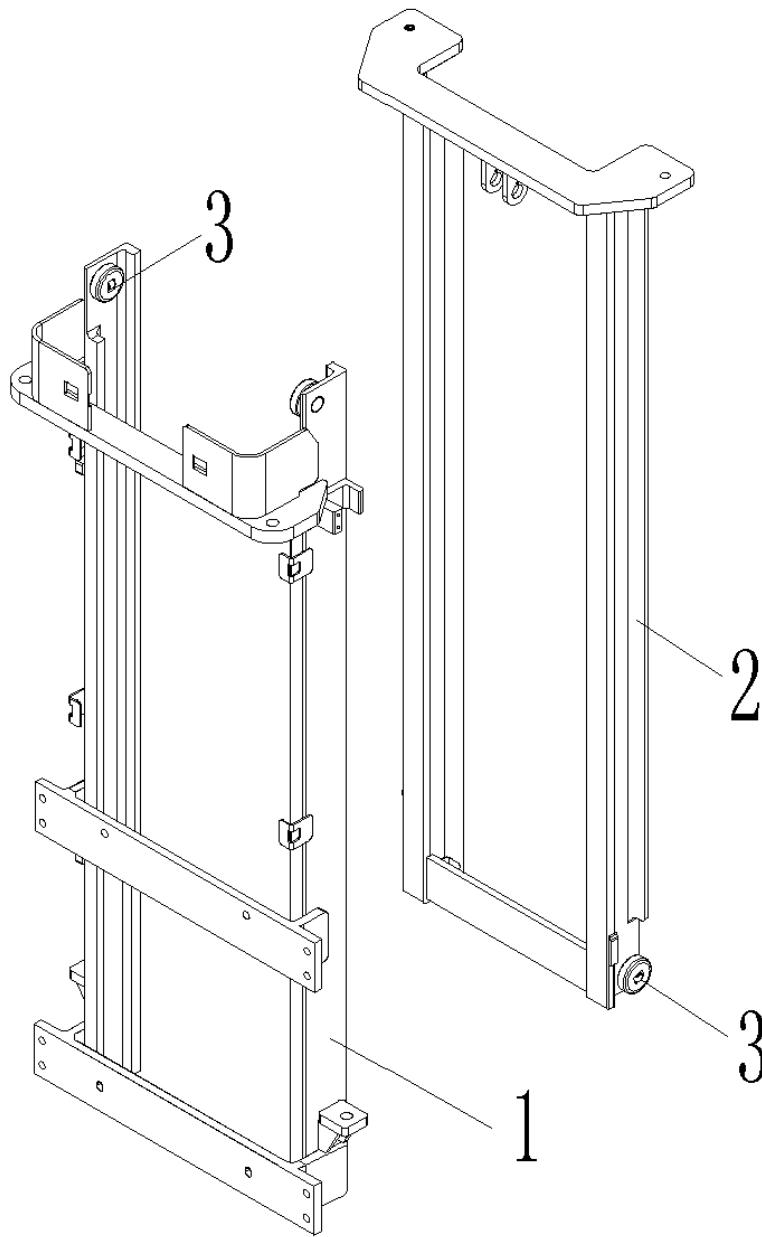

**Fig.15 Two-stage Mast System(standard lift)**

No.	Art No.	Description	Qty.	Note
1	9000015813	Mast	1	3600
	9000015821	Mast	1	3200
	9000015825	Mast	1	2900
2	9000015814	Mast	1	3600
	9000015822	Mast	1	3200
	9000015826	Mast	1	2900
3	3500100004	Roller	4	1

Fig.17 Three-stage mast chain system(full free lift)

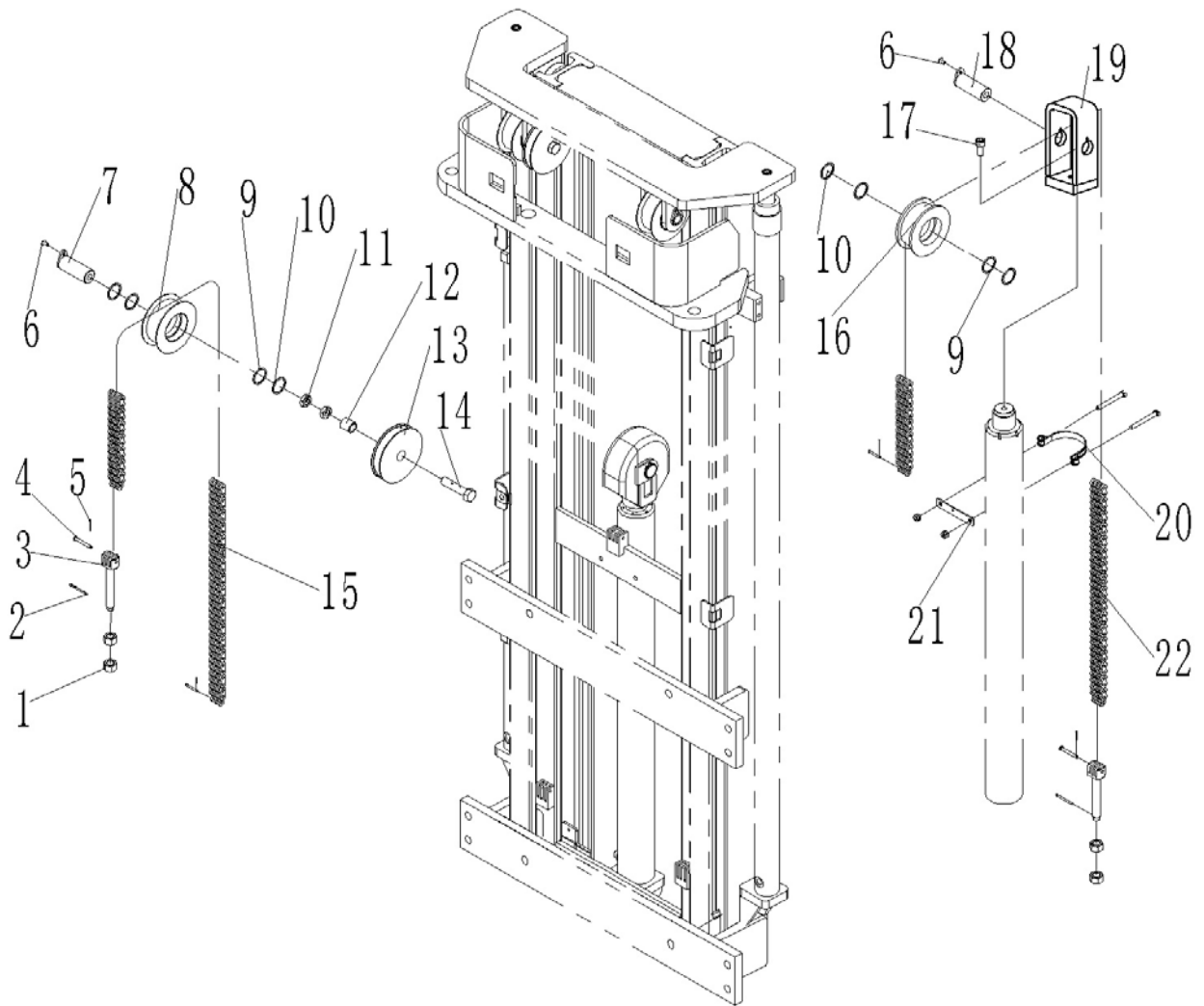
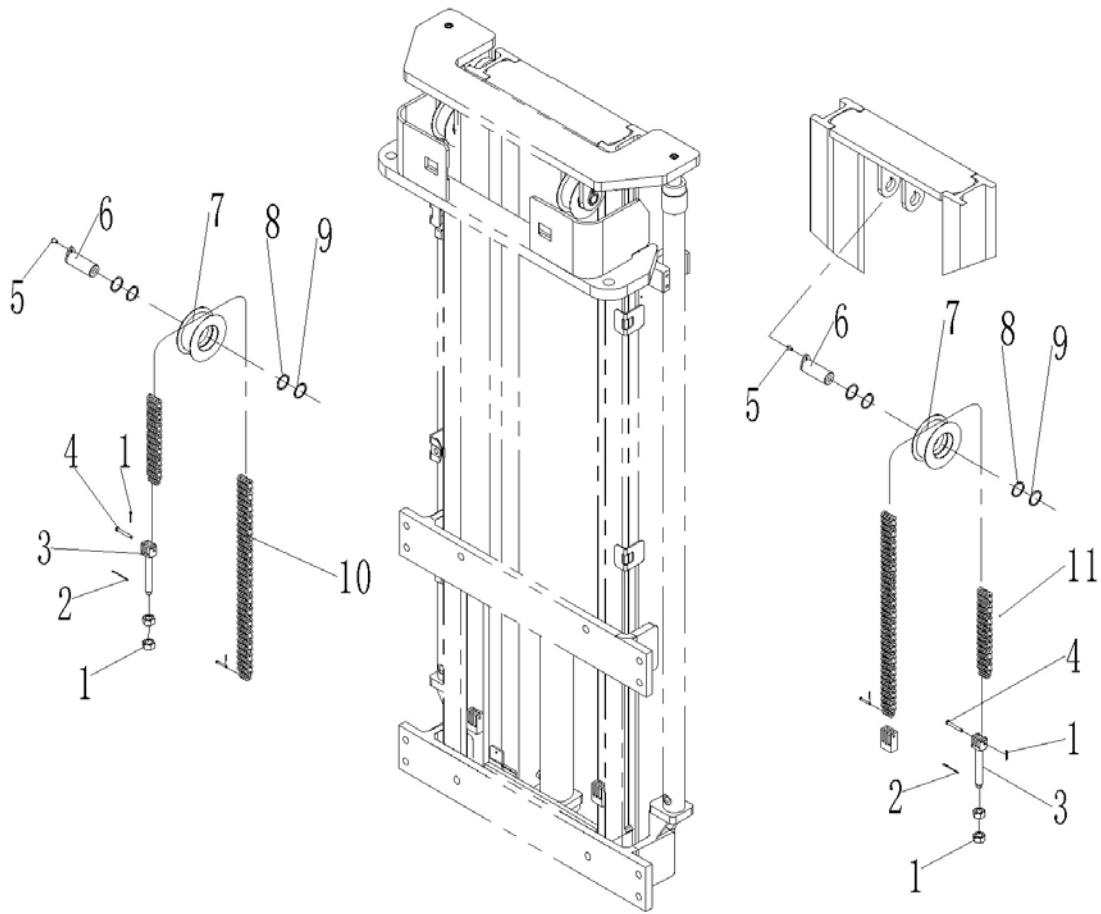



**Fig.16 Three-stage Mast Chain System(full free lift)**

No.	Art No.	Description	Qty.	Note
1	0090000442	Nut	6	M16x1.5
2	0000028011	Split pin	3	3x40
3	9000008260	Bolt	3	
4	0000028030	Short axle	6	6x45
5	0000028010	Split pin	6	2x20
6	0000023091	Screw	2	M6x12
7	9000009130	Chain wheel axle	2	
8	2390302024	Chain wheel for mast	2	
9	2000302002	Adjusting washer	6	(thickness 2)
10	9000015670	Adjusting washer	6	(thickness 4)
11	0000024010	Nut	2	M16
12	9000008245	Bearing bush	1	
13	9000008246	Pulley	1	
14	0000023123	Bolt	1	M16x70
15	0090000478	Chain LH1066x129	2	4600
	0000029070	Chain LH1066x123	2	4300
	0090000811	Chain LH1066x113	2	4000
16	9000015635	Chain wheel for mast	1	
17	0000023156	Screw	1	M12x25
18	9000015942	Chain wheel axle	1	
19	9000015829	Chain wheel seat	1	
20	9000009831	Hoop assembly	1	center distance 96
21	9000015319	Middle cylinder pad	1	
22	0090000847	Chain LH1266x69	1	4600
	0090000815	Chain LH1266x63	1	4300
	0090000810	Chain LH1266x55	1	4000

**Fig.18 Three-stage mast chain system(standard lift)**



**Fig.17 Three-stage mast chain system(standard lift)**

No.	Art No.	Description	Qty.	Note
1	0090000442	Nut	6	M16x1.5
2	0000028011	Split pin	9	3x40
3	9000015907	Bolt	3	
4	0000028030	Short axle	6	8x50
5	0000023091	Screw	3	M6x12
6	9000015942	Chain wheel axle	3	
7	9000015635	Chain wheel for mast	3	
8	2000302002	Adjusting washer	6	thickness 2
9	9000015670	Adjusting washer	6	thickness 4
10	0090000853	Chain LH1266x107	2	4600
	0090000852	Chain LH1266x101	2	4300
11	0090000618	Chain LH1266x105	1	4600
	0090000834	Chain LH1266x99	1	4300

Fig.19 Two-stage mast chain system(full free lift)

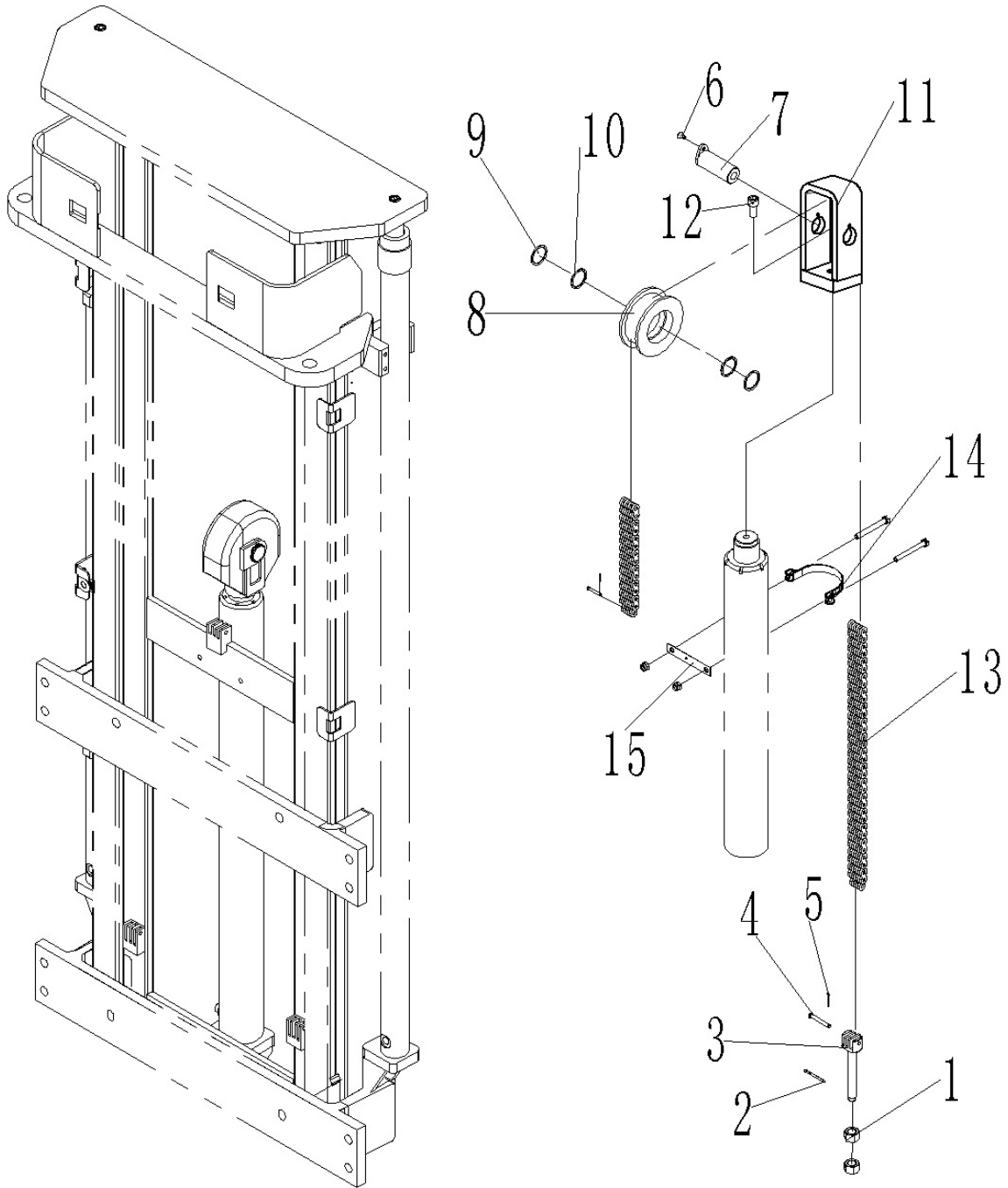

**Fig.18 Two-stage Mast Chain System(full free lift)**

No.	Art No.	Description	Qty.	Note
1	0090000442	Nut	2	M16x1.5
2	0000028011	Split pin	1	3x40
3	9000008260	Bolt	1	
4	0000028030	Short axle	2	8x50
5	0000028010	Split pin	2	2x20
6	0000023091	Screw		M6x12
7	9000015942	Chain wheel axle		
8	2390302024	Circlip for axle	1	
9	2000302002	Adjusting washer	2	( thickness 2 )
10	9000015670	Adjusting washer	2	( thickness 4 )
11	9000015829	Chain wheel seat	1	
12	0000023156	Screw	1	M12x25
13	0090000812	Chain LH1266x67	1	3600
	0090000813	Chain LH1266x61	1	3200
	0090000814	Chain LH1266x57	1	2900
	0090000810	Chain LH1266x55	1	2700
14	9000009831	Hoop assembly	1	center distance 96
15	9000015319	Middle cylinder pad	1	

**Fig.20 Two-stage mast chain system(standard lift)**

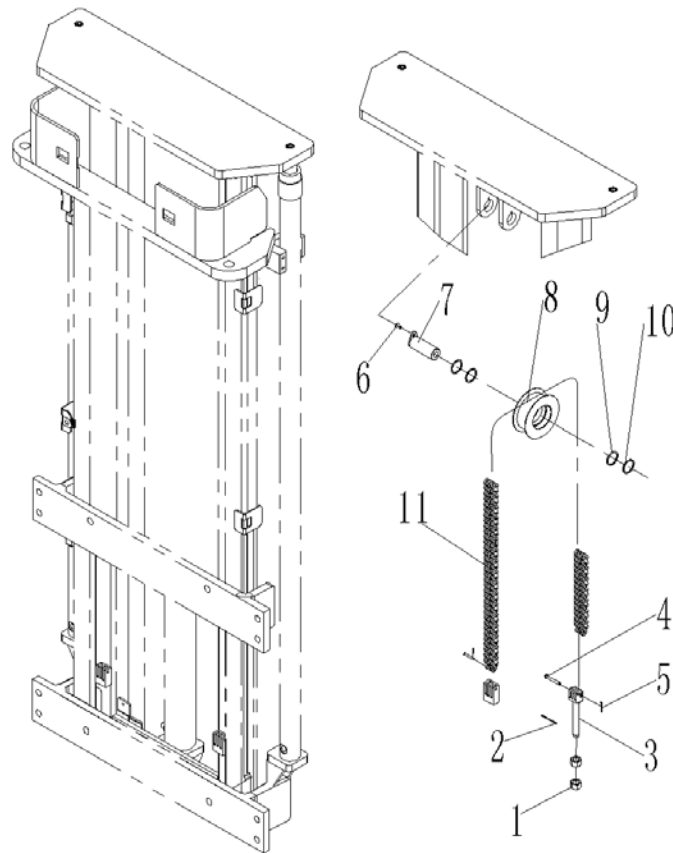

**Fig.19 Two-stage Mast Chain System(standard lift)**

No.	Art No.	Description	Qty.	Note
1	0090000442	Nut	2	M16x1.5
2	0000028011	Split pin	2	3x40
3	9000008260	Bolt	2	
4	0000028030	Short axle	2	8x50
5	0000028010	Split pin	1	2x20
6	0000023091	Screw	1	M6x12
7	9000015942	Chain wheel axle	1	
8	2390302024	Chain wheel for mast	1	
9	2000302002	Adjusting washer	2	(thickness 2)
10	9000015670	Adjusting washer	2	(thickness 4)
11	0090000807	Chain LH1266x113	1	3600
	0090000808	Chain LH1266x103	1	3200
	0090000809	Chain LH1266x95	1	2900

**Fig.21 Mast and other parts**

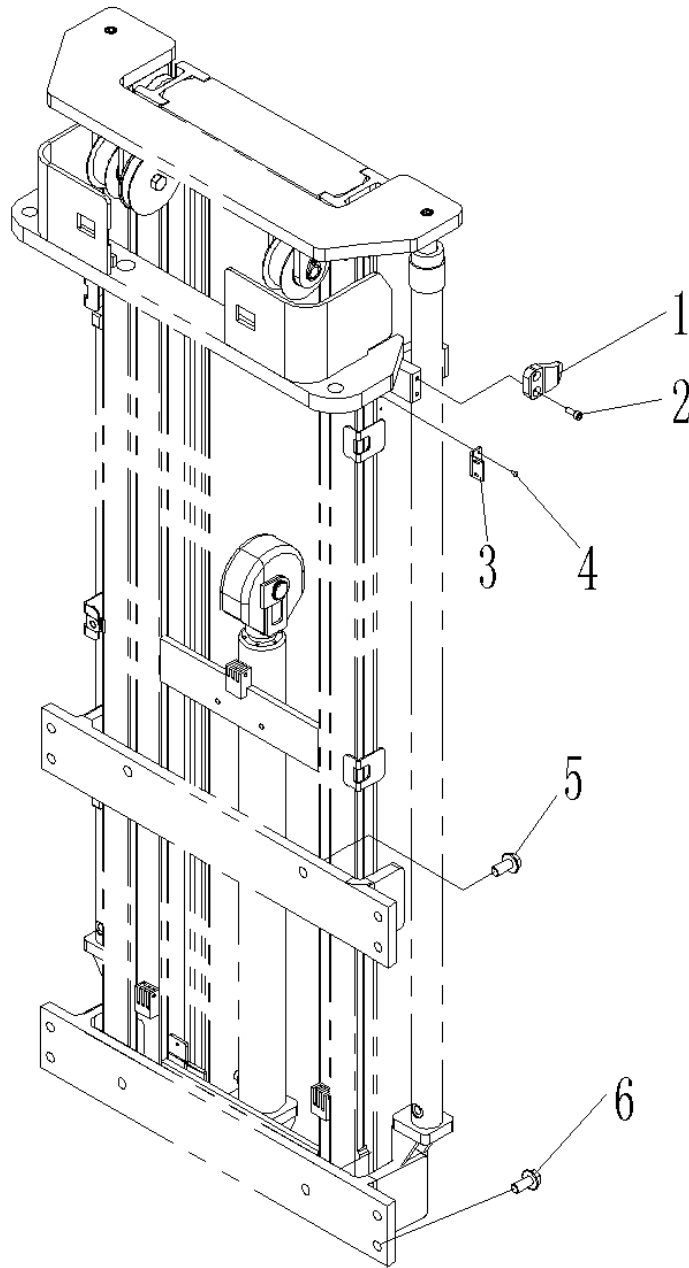

**Fig.20 Mast and other Parts**

No.	Art No.	Description	Qty.	Note
1	3018005004	Cylinder pressing plate	2	
2	0000023044	Screw	4	M8x20
3	9000015321	Limit switch fixing plate	1	
4	1000123003	Screw	2	M4x8
5	0090000658	Bolt	2	M16x35
6	0090000823	Bolt	10	M16x40

Fig.22 Three-stage mast hydraulic system(full free lift)

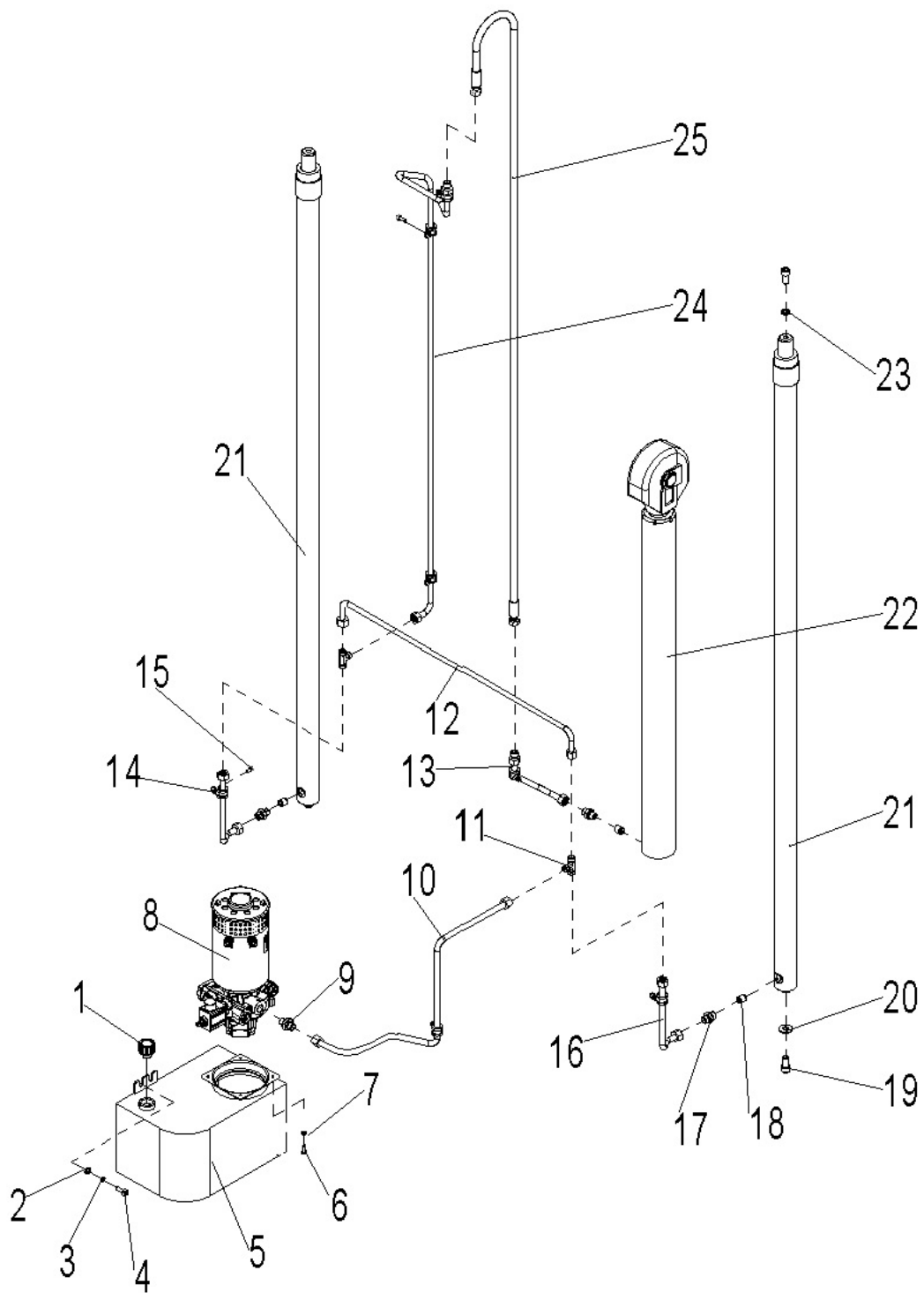
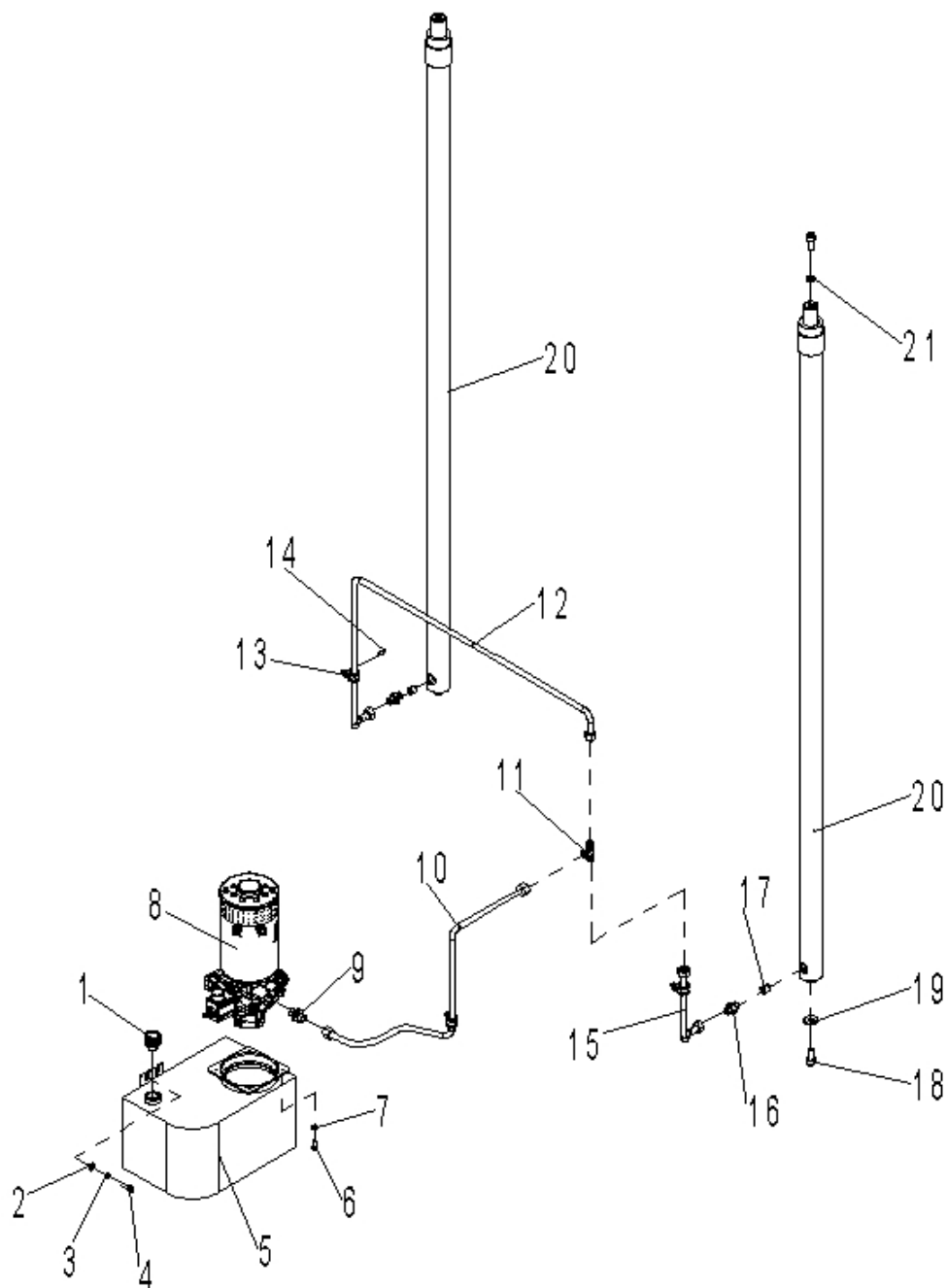

**Fig.21 Three-stage Mast Hydraulic System(full free lift)**

No.	Art No.	Description	Qty.	Note
1	2000303001	Air plug	1	
2	0000025011	Washer	2	8
3	0000025001	Washer	2	8
4	0000023044	Screw	2	M8x20
5	9000015438	Oil tank	1	
6	0090000025	Bolt	4	M6x16
7	0000025011	Washer	4	6
8	9000015649	DC hydraulic power unit	1	(without oil tank)
9	9000015645	G straight pipe joint	1	
10	9000015648	Special pipe assembly	1	
11	9000007846	Tee coupling	2	
12	9000015968	Connecting steel pipe	1	
13	9000015966	Middle cylinder steel tube	1	2
14	9000014895	YGE pipe clamp	3	
15	0000023604	Screw	3	M6x6
16	9000015923	Side tube	2	
17	9000007842	Straight pipe joint	3	
18	2000337001	Safety valve	3	
19	0000023094	Screw	4	M12x30
20	9000015320	Cylinder fixing pad	2	
21	9000015985	Outer cylinder	2	4600
	9000015991	Outer cylinder	2	4300
	9000015996	Outer cylinder	2	4000
22	9000015425	Middle cylinder	1	4600
	9000015449	Middle cylinder	1	4300
	9000015836	Middle cylinder	1	4000
23	0000025024	Washer	2	12
24	9000015967	Middle cylinder steel tube	1	4600
	9000015971	Middle cylinder steel tube	1	4300
	9000015978	Middle cylinder steel tube	1	4000
25	9000010286	Hydraulic hose assembly	1	
	9000010284	Hydraulic hose assembly	1	
	9000016324	Hydraulic hose assembly	1	



Fig.23 Three-stage mast hydraulic system(standard lift)



**Fig.22 Three-stage Mast Hydraulic System(standard lift)**

No.	Art No.	Description	Qty.	Note
1	2000303001	Air plug	1	
2	0000025011	Washer	2	8
3	0000025001	Washer	2	8
4	0000023044	Screw	2	M8x20
5	9000015438	Oil tank	1	
6	0090000025	Bolt	4	M6x16
7	0000025011	Washer	4	6
8	9000015649	DC hydraulic power unit	1	(without oil tank)
9	9000015645	G straight pipe joint	1	
10	9000015646	Special pipe assembly	1	
11	9000007846	Tee coupling	2	
12	9000015672	Connecting steel pipe	1	
13	9000014895	YGE pipe clamp	3	
14	0000023604	Screw	3	M6x6
15	9000015923	Side steel tube	1	
16	9000007842	Straight pipe joint	2	
17	2000337001	Safety valve	2	
18	0000023094	Screw	4	M12x30
19	9000015320	Cylinder fixing pad	2	
20	9000015943	Outer cylinder	2	4600
	9000015958	Outer cylinder	2	4300
21	0000025024	Washer	2	12

**Fig.24 Two-stage mast hydraulic system(full free lift)**

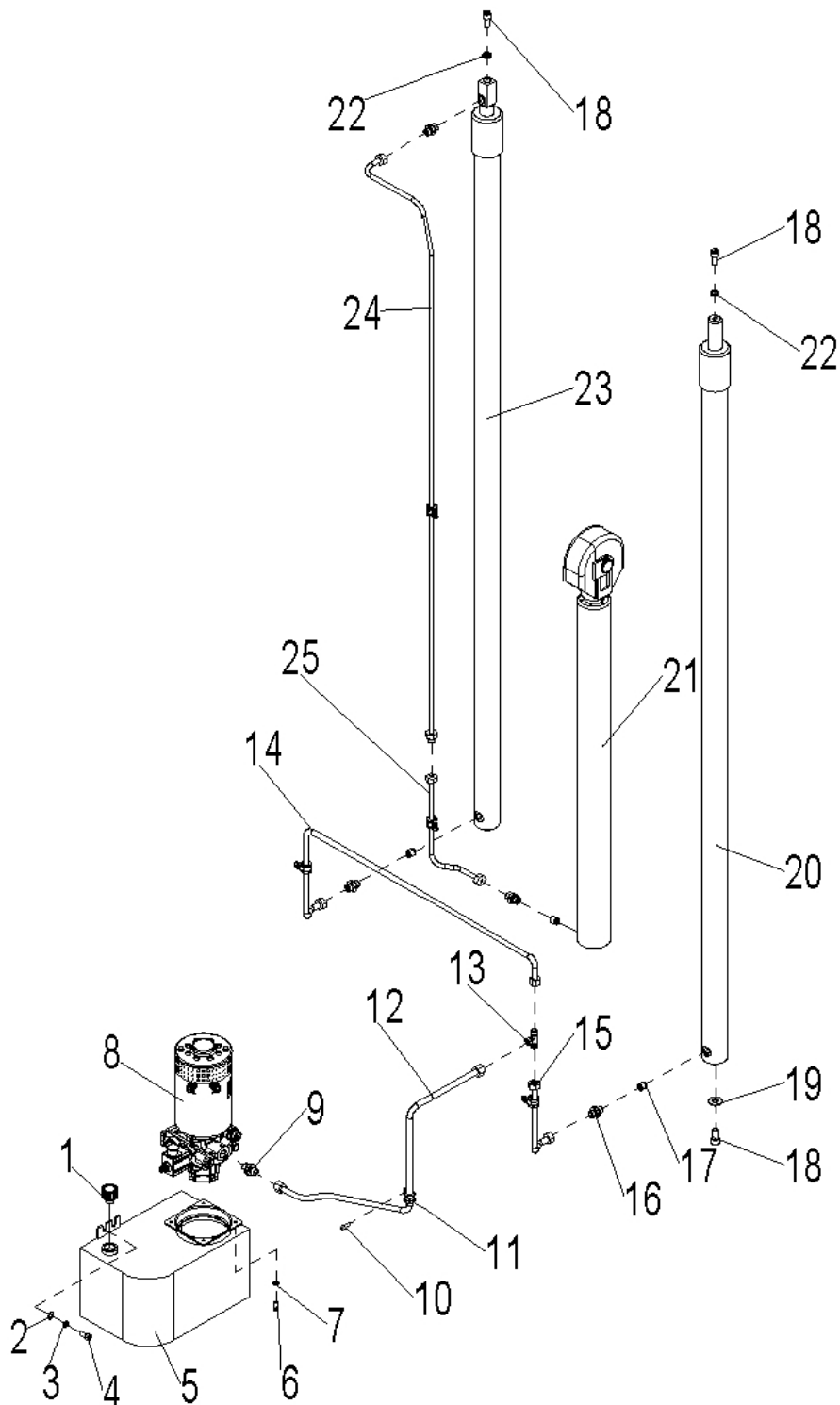
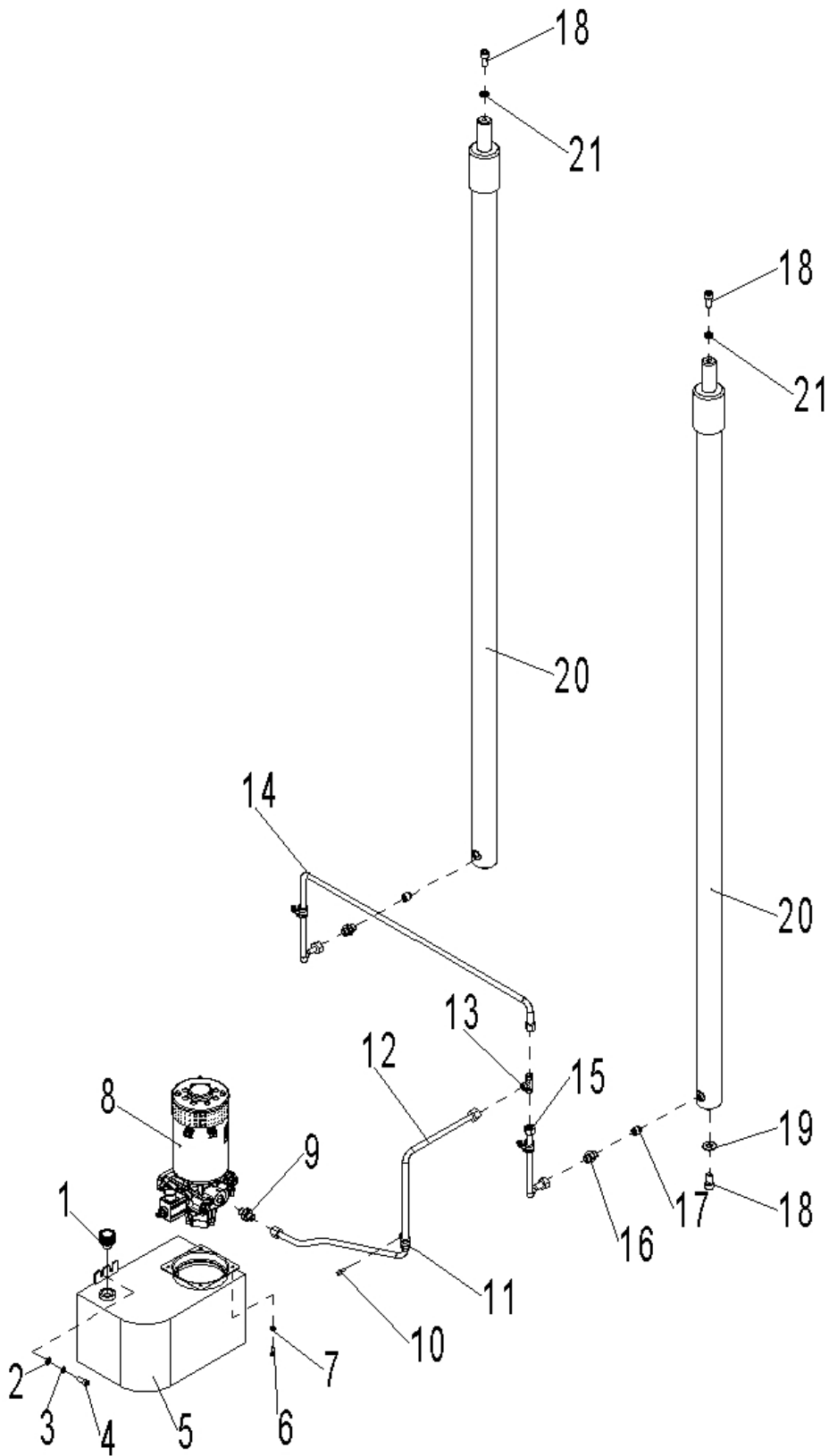

**Fig.23 Two-stage Mast Hydraulic System(full free lift)**

No.	Art No.	Description	Qty.	Note
1	2000303001	Air plug	1	
2	0000025011	Washer	2	8

3	0000025001	Washer	2	8
4	0000023044	Screw	2	M8x20
5	9000015438	Oil tank	1	
6	00900000025	Bolt	4	M6x16
7	0000025011	Washer	4	6
8	9000015649	DC hydraulic power unit	1	(without oil tank)
9	9000015645	G straight pipe joint	1	
10	0000023604	Screw	3	M6x6
11	9000014895	YGE pipe clamp	3	
12	9000015648	Special pipe assembly	1	
13	9000007846	Tee coupling	2	
14	9000015672	Connecting steel pipe	1	
15	9000015923	Side steel pipe	1	
16	9000007842	Straight pipe joint	2	
17	2000337001	Safety valve	2	
18	0000023094	Screw	4	M12x30
19	9000015320	Cylinder fixing pad	2	
20	9000015865	Right outer cylinder	1	3600
	9000015871	Right outer cylinder	1	3200
	9000015876	Right outer cylinder	1	2900
	9000015881	Right outer cylinder	1	2700
21	9000015235	Middle cylinder	1	3600
	9000015250	Middle cylinder	1	3200
	9000015259	Middle cylinder	1	2900
	9000015836	Middle cylinder	1	2700
22	0000025024	Washer	2	12
23	9000015866	Left outer cylinder	1	3600
	9000015872	Left outer cylinder	1	3200
	9000015877	Left outer cylinder	1	2900
	9000015882	Left outer cylinder	1	2700
24	9000015838	Middle cylinder steel pipe	1	
25	9000015842	Middle cylinder steel pipe 2	1	
	9000015847	Middle cylinder steel pipe 2	1	
	9000015852	Middle cylinder steel pipe 2	1	
	9000015857	Middle cylinder steel pipe 2	1	

Fig.25 Two-stage mast hydraulic system(standard lift)



**Fig.24 Two-stage Mast Hydraulic System(standard lift)**

No.	Art No.	Description	Qty.	Note
1	2000303001	Air plug	1	
2	0000025011	Washer	2	8
3	0000025001	Washer	2	8
4	0000023044	Screw	2	M8x20
5	9000015438	Oil tank	1	
6	0090000025	Bolt	4	M6x16
7	0000025011	Washer	4	6
8	9000015649	DC hydraulic power unit	1	(without oil tank)
9	9000015645	G straight pipe joint	1	
10	0000023604	Screw	3	M6x6
11	9000014895	YGE pipe clamp	3	
12	9000015648	Special pipe assembly	1	
13	9000007846	Tee coupling	2	
14	9000015672	Connecting steel pipe	1	
15	9000015923	Side steel pipe	1	
16	9000007842	Straight pipe joint	2	
17	2000337001	Safety valve	2	
18	0000023094	Screw	4	M12x30
19	9000015320	Cylinder fixing pad	2	
20	9000015815	Outer cylinder	2	3600
	9000015823	Outer cylinder	2	3200
	9000015827	Outer cylinder	2	2900
21	0000025024	Washer	2	12

Fig.26 Three-stage mast outer cylinder assembly(full free lift)

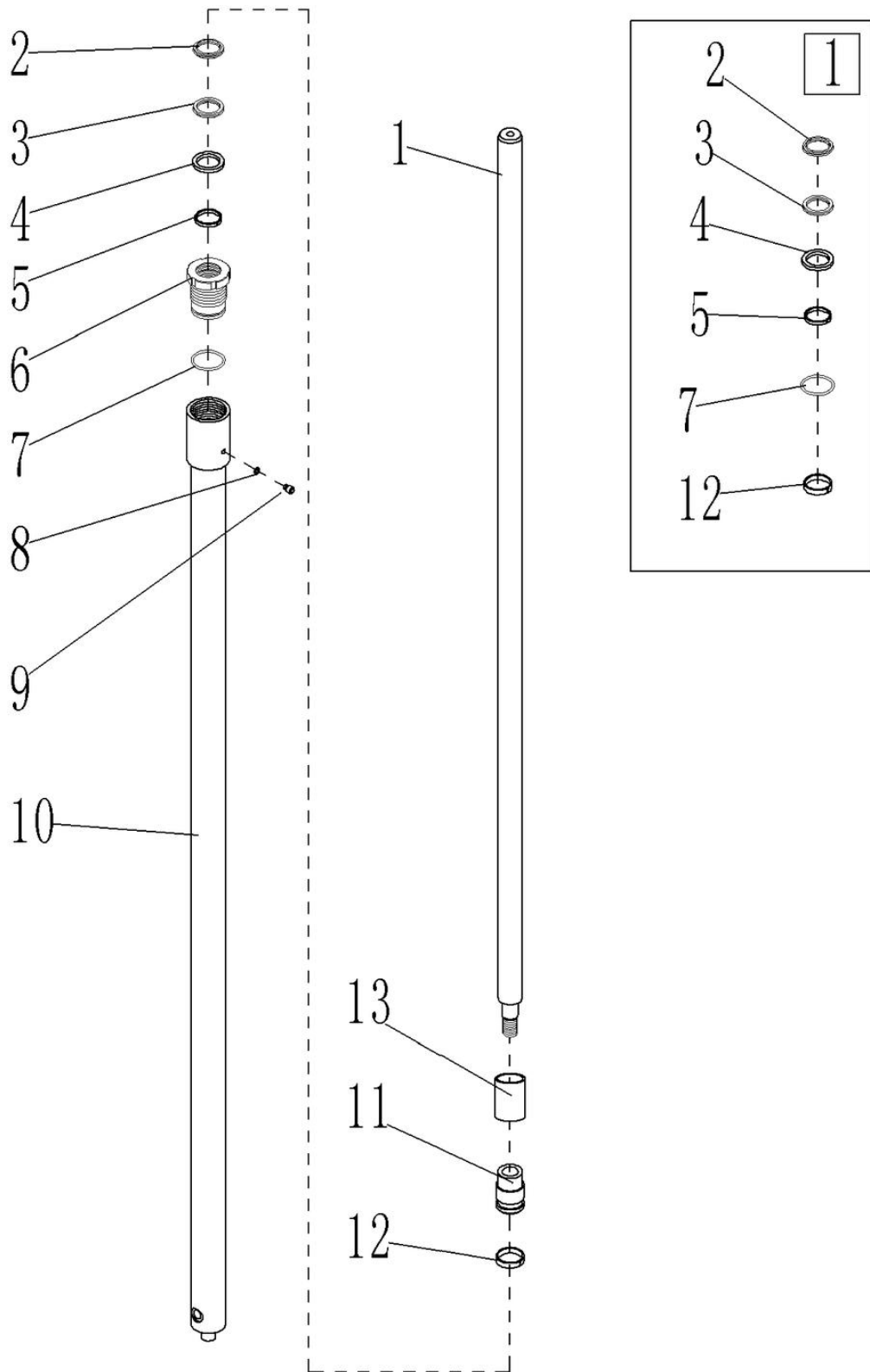
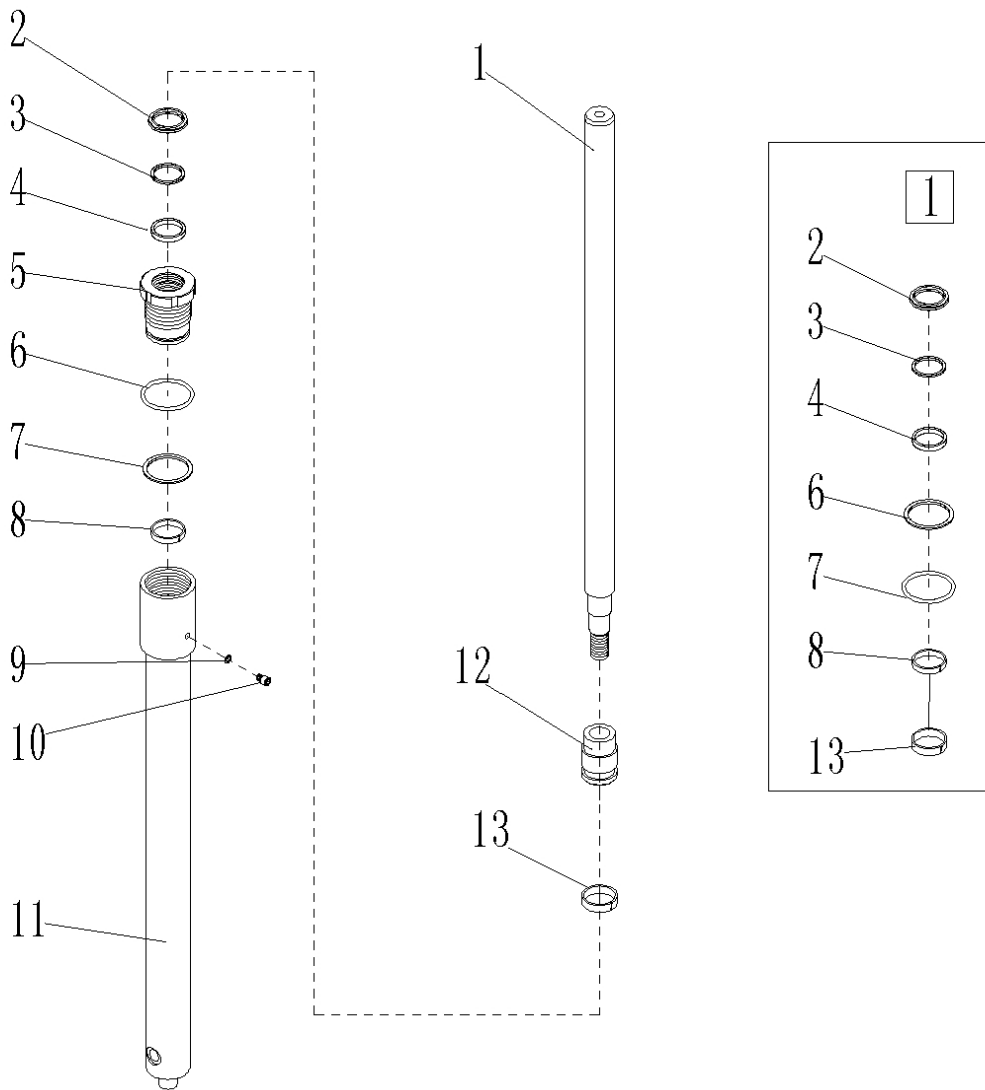

**Fig.25 Three-stage Mast outer Cylinder Assembly(full free lift)**

No.	Art No.	Description	Qty.	Note
1	9000015962	Piston rod	1	4600
	9000015969	Piston rod	1	4300
	9000015974	Piston rod	1	4000
2	9000009926	Dust ring	1	40x48x5/6.5
3	9000009170	Y ring	1	
4	9000015671	Seal ring	1	40x50.7x4.2
5	9000015668	Supporting ring	1	40x44x15
6	9000015963	Cylinder cover	1	
7	9000015660	O ring	1	49.4x3.1
8	0000022026	Combined seal washer	1	8
9	0000023415	Screw	1	M8x10
10	9000015964	Cylinder barrel	1	4600
	9000015970	Cylinder barrel	1	4300
	9000015975	Cylinder barrel	1	4000
11	9000015965	Piston	1	
12	9000015661	Supporting ring	1	40x45x10
13	9000016327	Adjusting sleeve	1	
①	9000016329	Outer cylinder seal assembly	1	



**Fig.27 Three-stage mast middle cylinder assembly(full free lift)**



**Fig.26 Three-stage Mast middle Cylinder Assembly(full free lift)**

No.	Art No.	Description	Qty.	Note
1	9000015323	Piston rod	1	4600
	9000015386	Piston rod	1	4300
	9000016470	Piston rod	1	4000
2	9000015662	Dust ring	1	56x64x5/6.5
3	9000015663	Stop collar	1	56x66x2
4	9000010181	Seal ring	1	56x66x10/11
5	9000015322	End cover	1	
6	9000015664	O ring	1	64.4x3.1
7	9000015665	Stop collar	1	65x70x1.25
8	9000015666	Supporting ring	1	56x60x9.7
9	0000022026	Combined sealing washer	1	8
10	0000023415	Screw	1	M8x10
11	9000015324	Cylinder barrel	1	4600
	9000015387	Cylinder barrel	1	4300
	9000016471	Cylinder barrel	1	4000
12	9000015325	Piston	1	
13	9000015667	Supporting ring	1	58x63x9.7
①	9000015674	Middle cylinder seal assembly	1	

Fig.28 Three-stage mast outer cylinder assembly(standard lift)

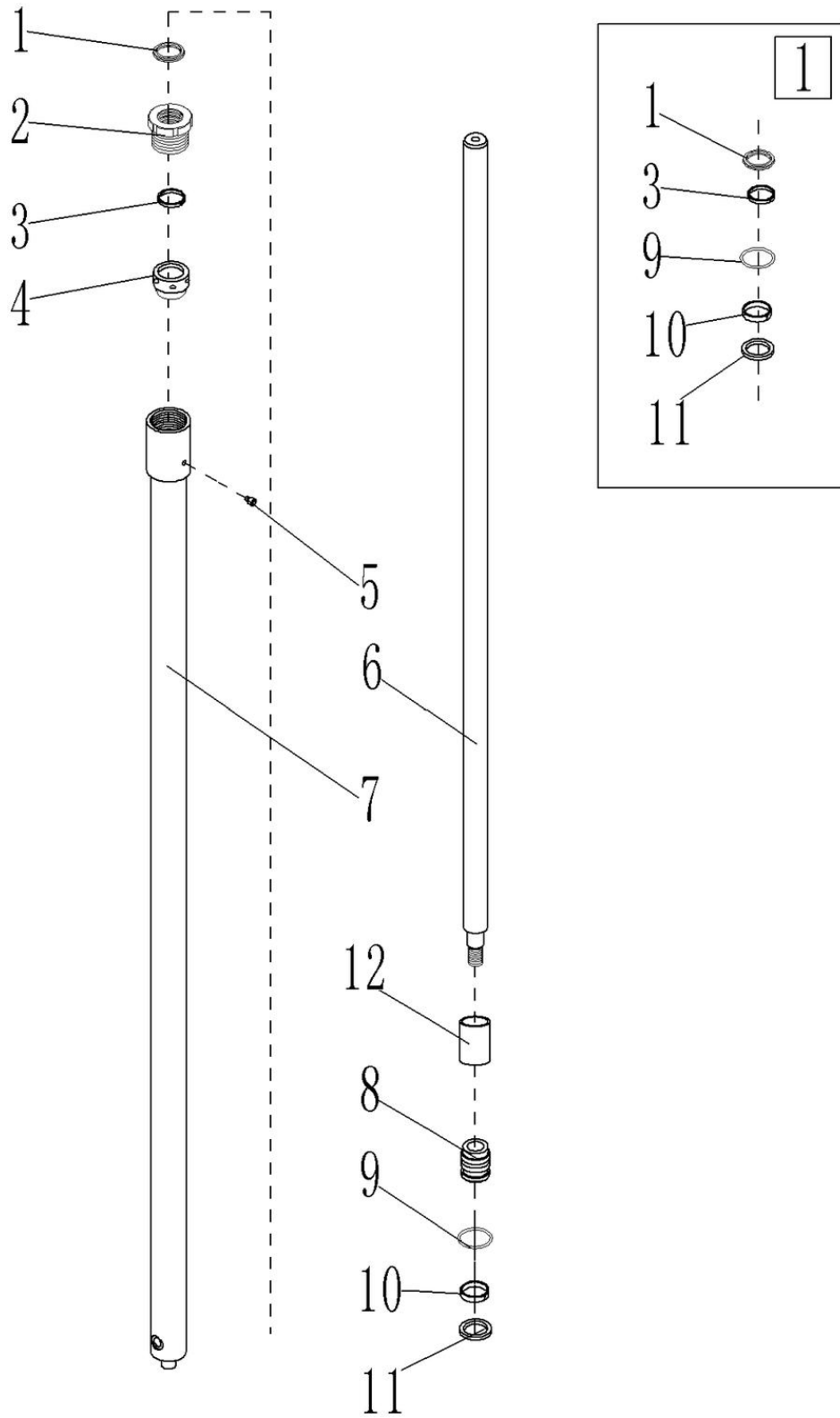

**Fig.27 Three-stage Mast outer Cylinder Assembly(standard lift)**

No.	Art No.	Description	Qty.	Note
1	9000009926	Dust ring	1	40X48X5/6.5
2	9000009183	Blind nut	1	
3	9000015668	Supporting ring	1	40X44X15
4	9000009184	Spacer bush	1	
5	0090000827	Screw		Rc1/8
6	9000015909	Piston rod	1	4600
	9000015932	Piston rod	1	4300
7	9000015910	Cylinder barrel	1	4600
	9000015933	Cylinder barrel	1	4300
8	9000015912	Piston	1	
9	9000016328	O ring	1	44.4x3.1
10	9000009182	Supporting ring	1	46X50X15
11	9000009178	Y ring	1	40X50X6/7
12	9000015911	Limit sleeve		
①	9000016330	Outer cylinder seal assembly	1	

Fig.29 Two-stage mast outer cylinder assembly(full free lift)

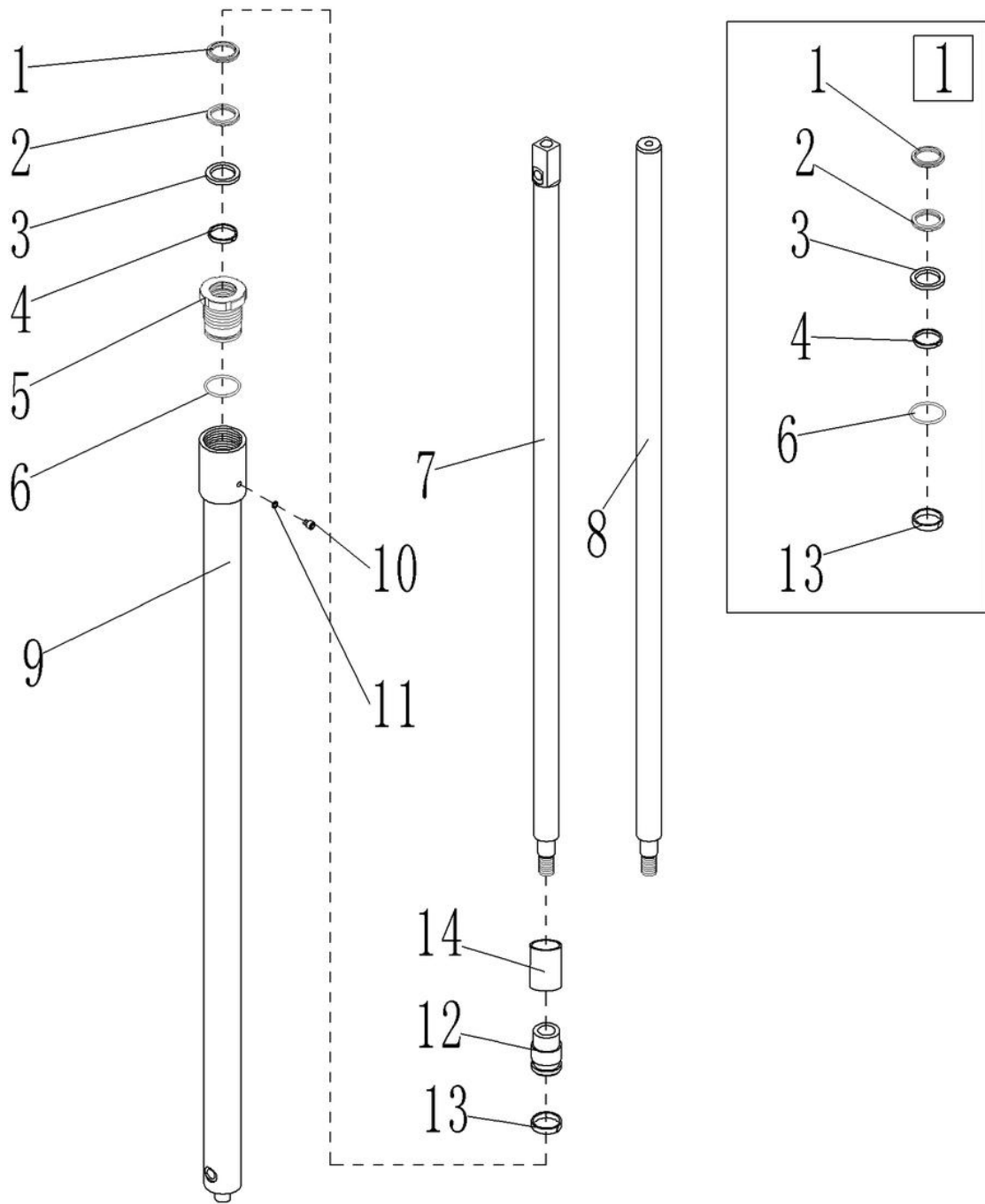

**Fig.28 Two-stage Mast outer Cylinder Assembly(full free lift)**

No.	Art No.	Description	Qty.	Note
1	9000015669	Dust ring	1	28x36x4.5/6
2	9000009708	Seal ring	1	28x35.5x5/5.7
3	9000009710	Seal ring	1	28x38.7x4.2
4	9000009711	Supporting ring	1	28x32x10
5	9000015238	Cylinder cover	1	
6	9000015660	O ring	1	49.4x3.1
7	9000015839	Piston rod	1	3600 left cylinder
	9000015845	Piston rod	1	3200 left cylinder
	9000015850	Piston rod	1	2900 left cylinder
	9000015855	Piston rod	1	2700 left cylinder
8	9000015866	Piston rod	1	3600 right cylinder
	9000015848	Piston rod	1	3200 right cylinder
	9000015853	Piston rod	1	2900 right cylinder
	9000015859	Piston rod	1	2700 right cylinder
9	9000015841	Cylinder barrel	1	3600
	9000015846	Cylinder barrel	1	3200
	9000015851	Cylinder barrel	1	2900
	9000015856	Cylinder barrel	1	2700
10	0000022026	Combined sealing washer	1	8
11	0000023415	Screw	1	M8x10
12	9000015225	Piston	1	
13	9000015661	Supporting ring	1	40x45x10
14	9000015841	Adjusting sleeve	1	
①	9000016331	Outer cylinder seal assembly	1	

**Fig.30 Two-stage mast middle cylinder assembly(full free lift)**

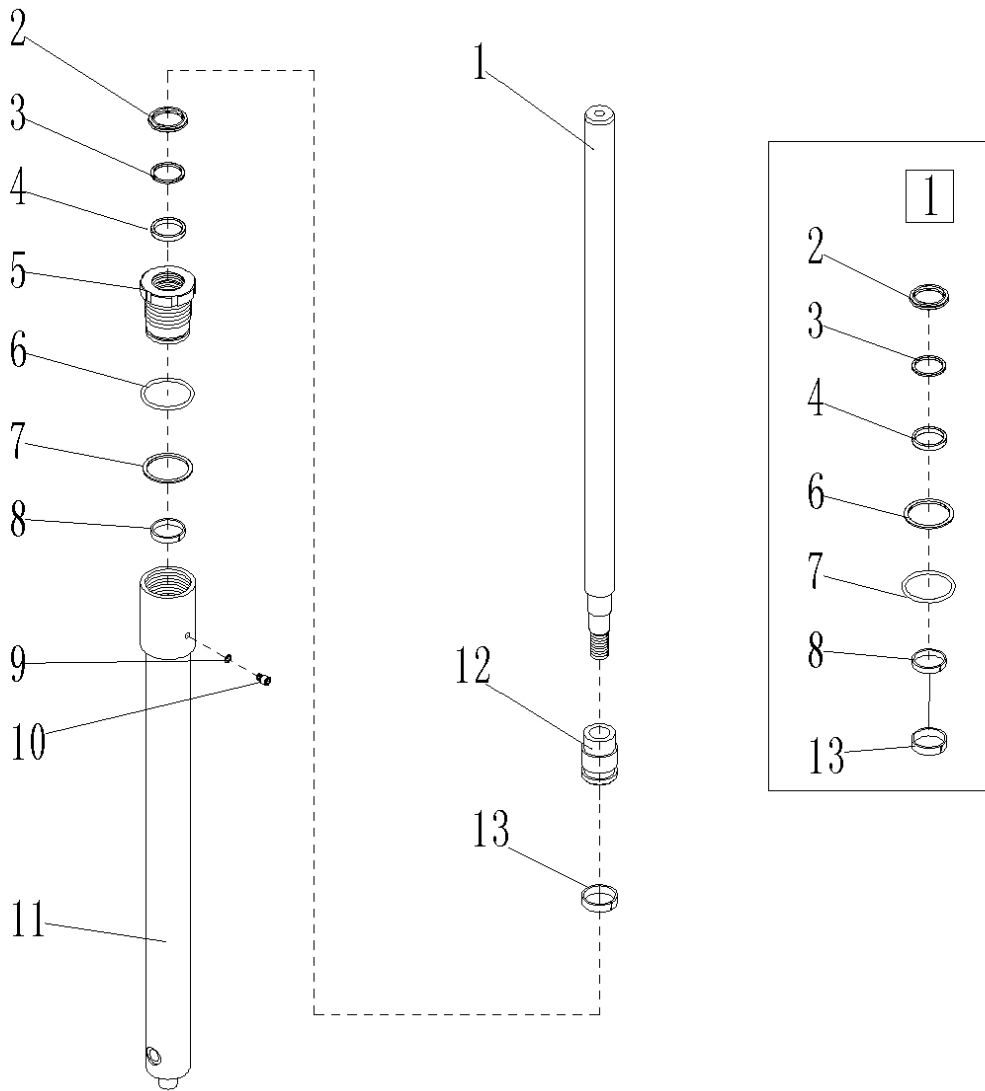
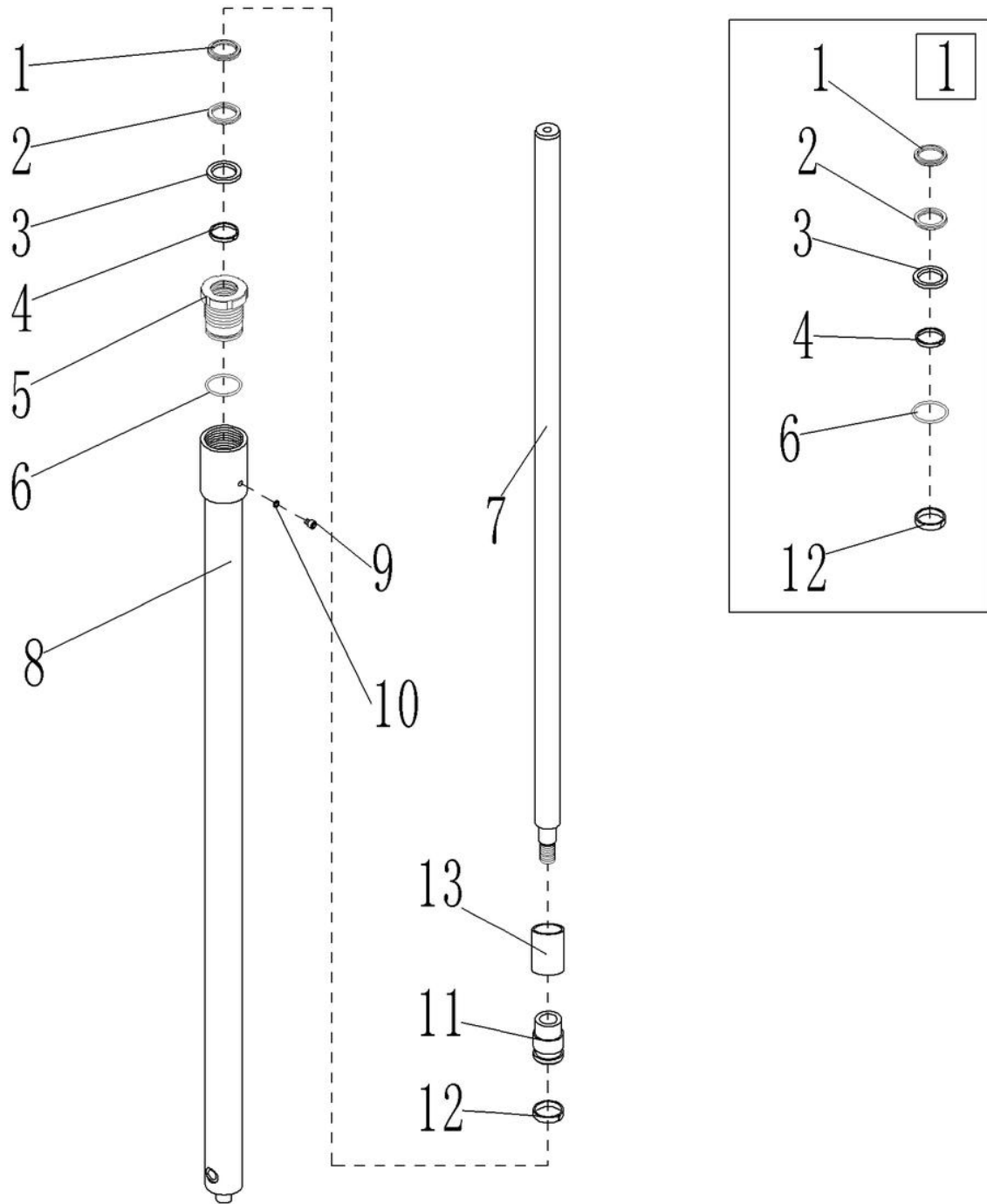

**Fig.29 Two-stage Mast middle Cylinder Assembly(full free lift)**

No.	Art No.	Description	Qty.	Note
1	9000015223	Piston rod	1	3600
	9000015226	Piston rod	1	3200
	9000015260	Piston rod	1	2900
	9000016470	Piston rod	1	2100
2	9000015662	Dust ring	1	56x64x5/6.5
3	9000015663	Stop collar	1	56x66x2
4	9000010181	Seal ring	1	56x66x10/11
5	9000015322	End cap	1	
6	9000015664	O ring	1	64.4x3.1
7	9000015665	Stop collar	1	65x70x1.25
8	9000015666	Supporting ring	1	56x60x9.7
9	0000022026	Combined sealing washer	1	8
10	0000023415	Screw	1	M8x10
11	9000015236	Cylinder barrel	1	3600
	9000015251	Cylinder barrel	1	3200
	9000015261	Cylinder barrel	1	2900
	9000016471	Cylinder barrel	1	2700
12	9000015325	Piston	1	
13	9000015667	Supporting ring	1	58x63x9.7
①	9000015677	Middle cylinder seal assembly	1	



Fig.31 Two-stage mast outer cylinder assembly(standard lift)



**Fig.30 Two-stage Mast outer Cylinder Assembly(standard lift)**

No.	Art No.	Description	Qty.	Note
1	9000009926	Dust ring	1	40x48x5/6.5
2	9000009170	Y ring	1	
3	9000015671	Seal ring	1	40x50.7x4.2
4	9000009927	Supporting ring	1	40X44X10
5	9000015181	Cylinder cover	1	
6	9000015660	O ring	1	49.4x3.1
7	9000015795	Piston rod	1	3600
	9000015799	Piston rod	1	3200
	9000015806	Piston rod	1	2900
8	9000015796	Cylinder barrel	1	3600
	9000015800	Cylinder barrel	1	3200
	9000015807	Cylinder barrel	1	2900
9	0000023415	Screw	1	M8x10
10	0000022026	Combined sealing washer	1	8
11	9000015225	Piston	1	
12	9000015661	Supporting ring		40x45x10
13	9000015797	Adjusting sleeve		
①	9000016332	Outer cylinder seal assembly	1	

**Fig.32 Drive system assembly**

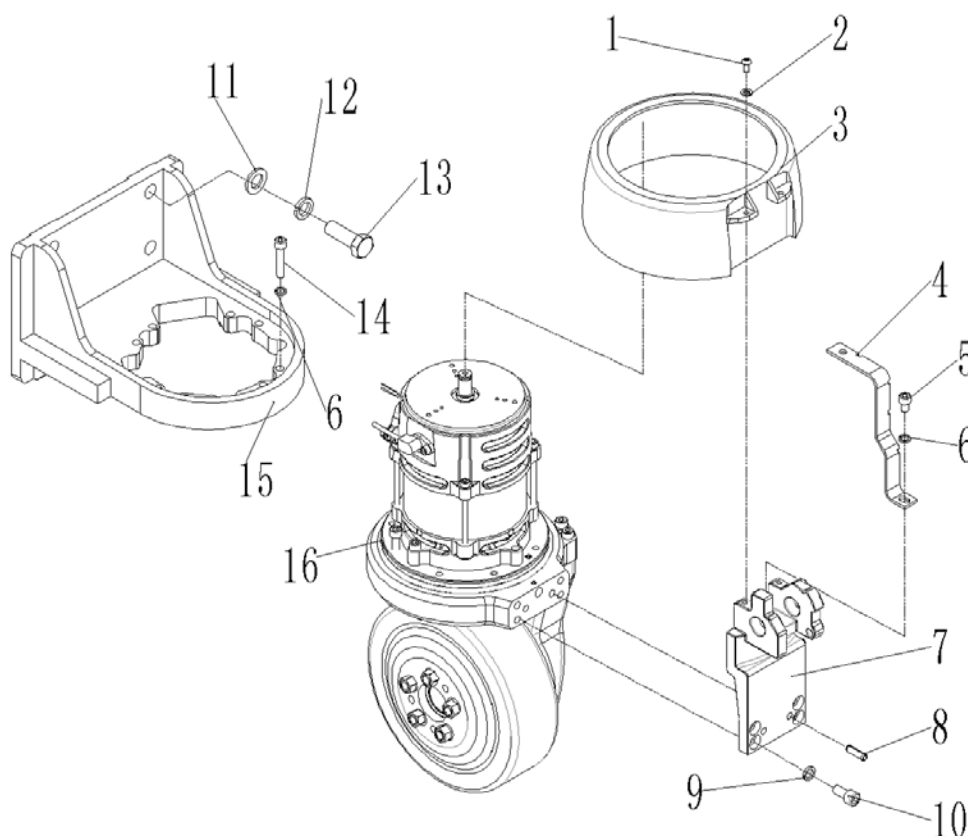

**Fig.31 Drive System Assembly**

No.	Art No.	Description	Qty.	Note
1	0000023045	Screw	2	M6x12
2	0000023055	Washer	2	6
3	9000015376	Driving wheel cover	1	
4	9000015378	Cable holder	1	
5	0000023089	Screw	1	M8x12
6	0000025001	Washer	5	8
7	9000011355	Handle seat	1	
8	0000028116	Elastic dowel pin	2	8x26
9	0000023006	Washer	4	10
10	0000023034	Screw	4	M10x20
11	0000025029	Washer	4	16
12	0000025055	Washer	4	16
13	0000023583	Bolt	4	M16x45
14	0000023077	Screw	4	M8x40
15	9000015377	Driving wheel seat	1	
16	2520504001	AC vertical drive assembly	1	

Fig.33 Load wheel assembly

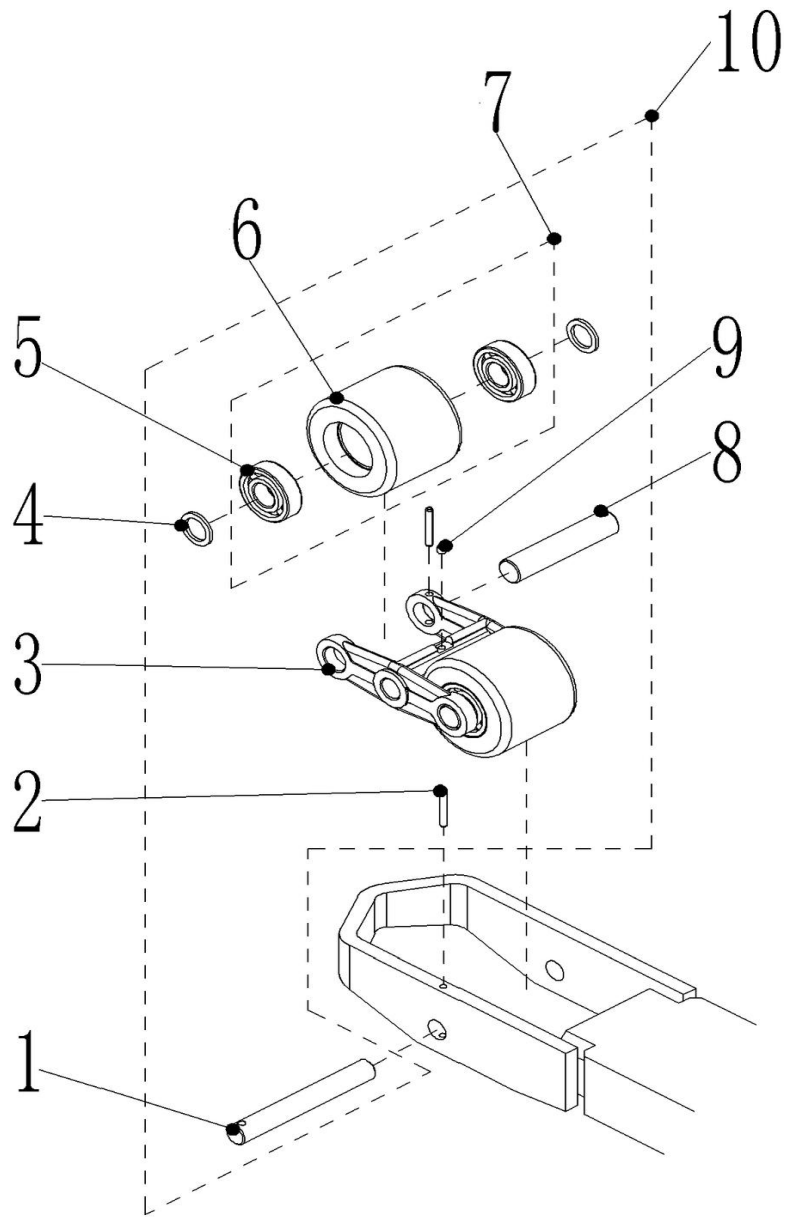

**Fig.32 Load Wheel Assembly**

No.	Art No.	Description	Qty.	Note
1	9000012092	Connecting shaft	2	
2	0000028009	Elastic dowel pin	6	5x35
3	9000012093	Double wheel carrier	2	
4	9000010718	Adjusting washer	8	(thickness 2.5)
5	0000027001	Bearing	8	6204
6	1000507011	Load wheel	4	Ø84X70
7	9000010727	Wheels fittings	4	
8	9000012094	Small wheel shaft	4	
9	0000030001	Grease cup	1	6
10	9000010728	Load wheel assembly	2	

**Fig.34 Handle assembly**

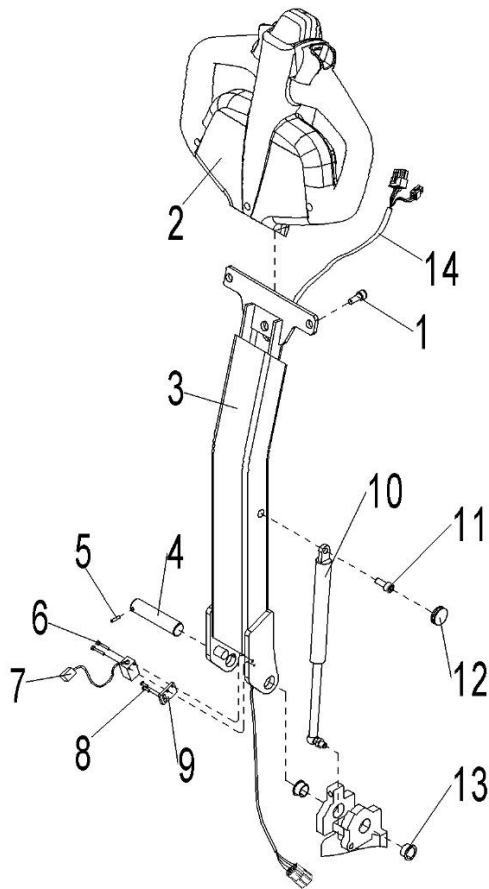

**Fig.33 Handle Assembly**

No.	Art No.	Description	Qty.	Note
1	0000023047	Screw	2	M8x25
2	1100100001	Canbus control handle C	1	94300-90
3	9000010693	Handle bar	1	
4	9000010694	Spindle	1	
5	0000028024	Elastic dowel pin	1	4x16
6	0000023075	Screw	2	M3x20
7	900000832	Proximity switch	1	NBN5-F7-E2
8	0000023056	Screw	2	M4x12
9	9000010695	Switch baseplate	1	
10	9000011289	Air spring	1	
11	0000023044	Screw	1	M8x20
12	9000010696	Envelope	1	
13	0000013002	bushing	2	20x22x12
14	9000010635	Handle control harness	1	

**Fig.35 Pump system**

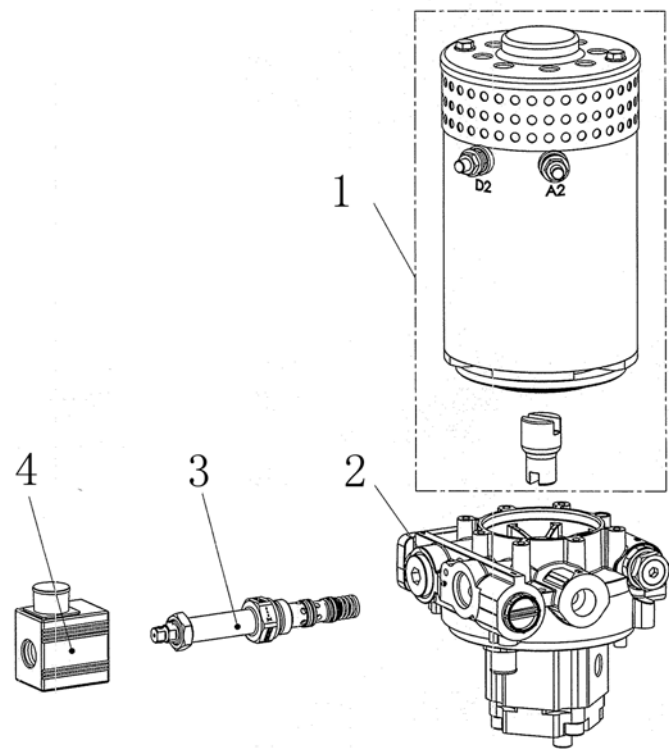

**Fig.34 Pump System**

No.	Art No.	Description	Qty.	Note
1	9000015637	Motor	1	3.2KW
2	9000015638	Centre valve	1	
3	9000015639	Solenoid valve core	1	
4	9000015640	Coil	1	

**Fig.36 Main circuit harness**

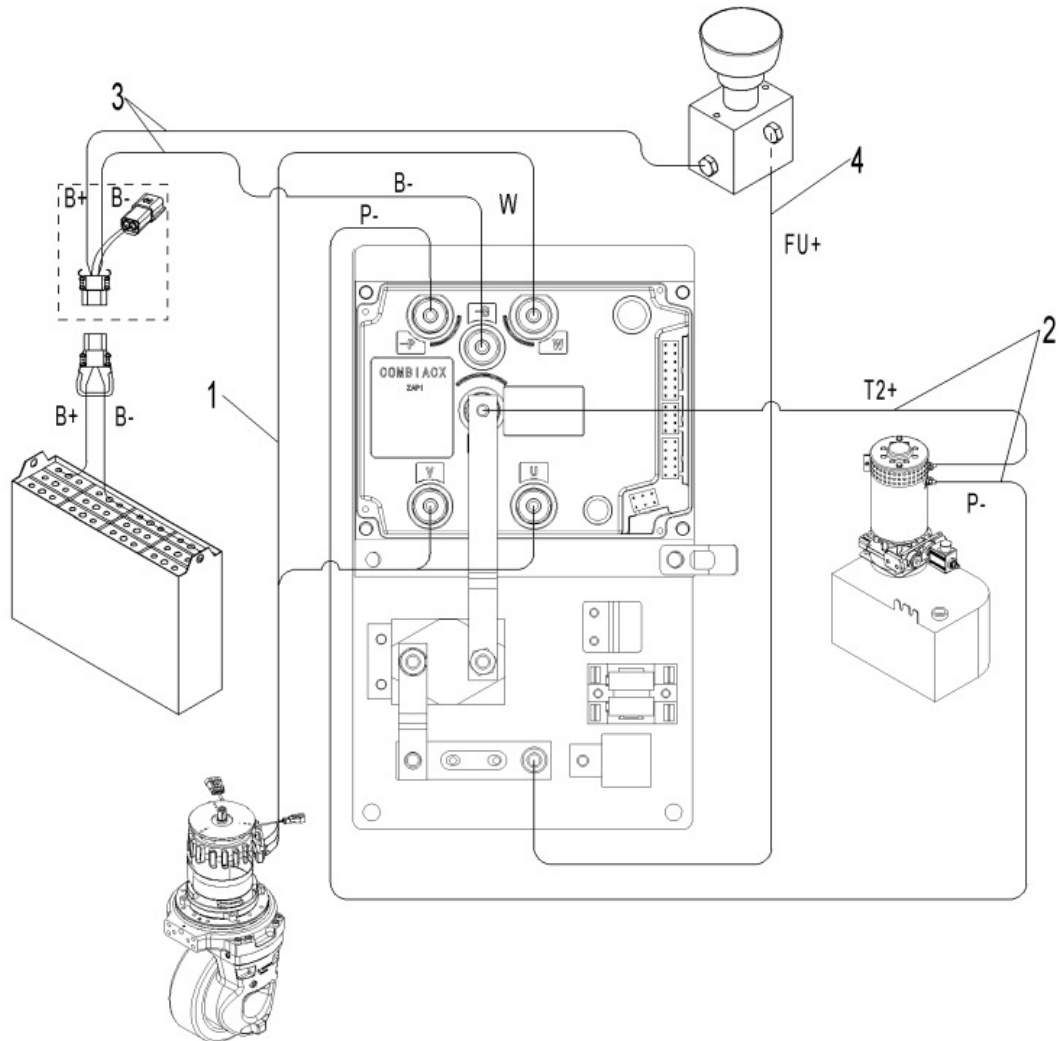
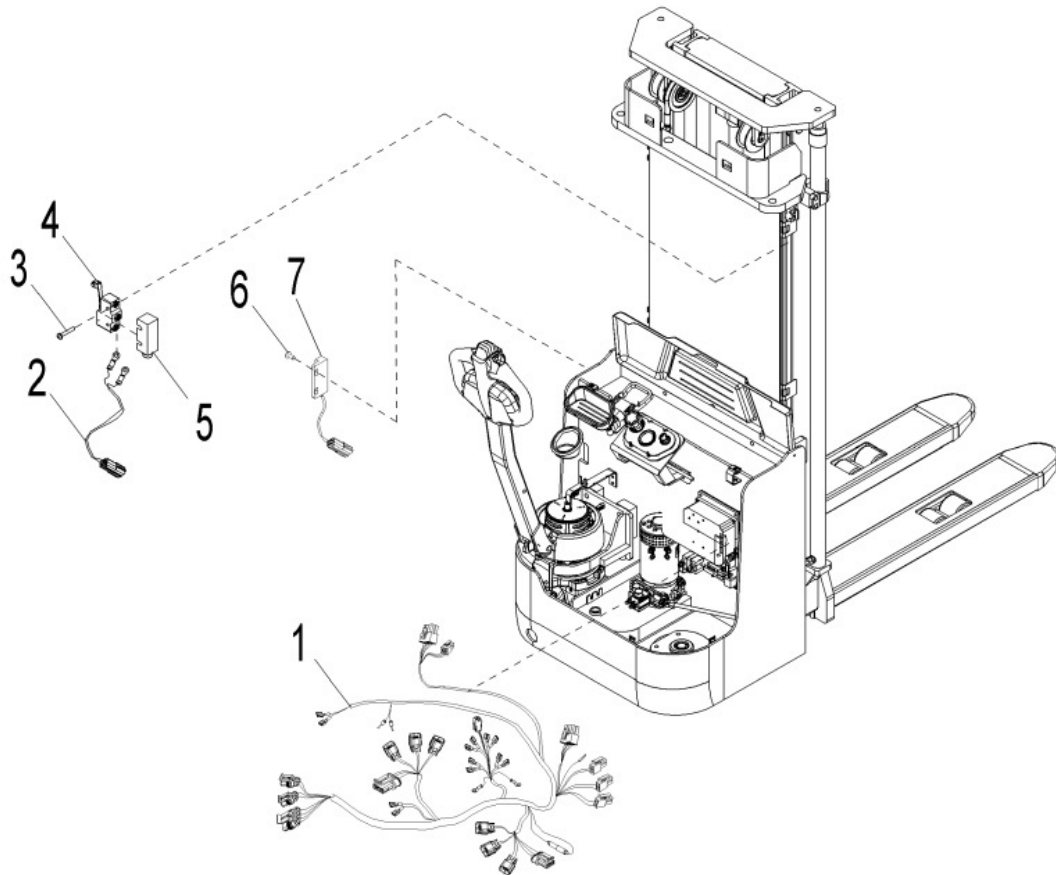

**Fig.35 Main circuit harness**

No.	Art No.	Description	Qty.	Note
1	9000010652	Drive motor harness	1	
2	9000010653	Pump motor harness	1	
3	9000016350	Power harness	1	
4	9000016351	Harness	1	FU+



**Fig.37 Electrical general part**



**Fig.36 Electrical general Part**

No.	Art No.	Description	Qty.	Note
1	9000016349	Main control harness	1	
2	9000008360	Limit control harness	1	
3	0000023033	Screw	2	M4×25
4	2040634001	Micro switch	1	XZ-15GW22-B
5	2040603002	Micro switch protective cover	1	
6	0000023216	Screw	3	M3×8
7	9000008332	Magnet switch	1	HWK23

**Fig.38 Controller assembly**

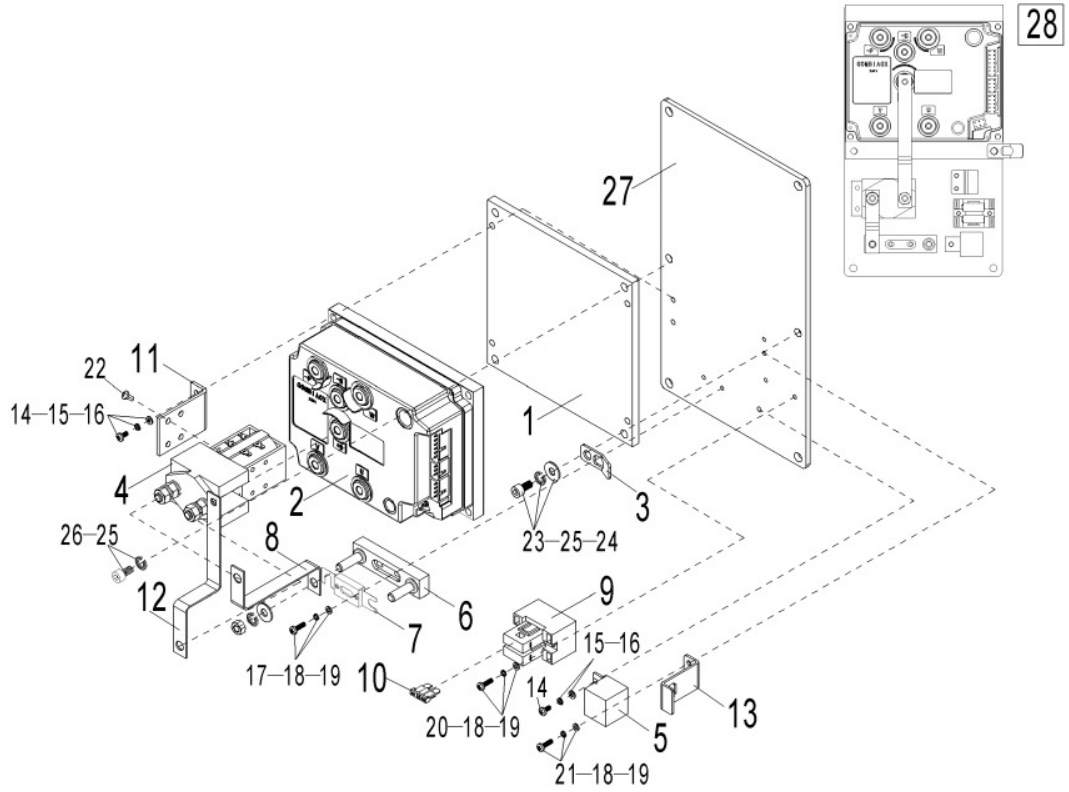

**Fig.37 Controller Assembly**

No.	Art No.	Description	Qty.	Note
1	9000010659	Aluminium plate	1	
2	9000016047	Controller	1	COMBIACX 24/240 270 C
3	9000009791	Line hanging board	3	
4	2390434003	Contactora	1	SW180B-4 DC24V
5	1000434041	Relay	1	ACR01F-F-1AD DC24V
6	1000434007	Fuse seat	1	SYV
7	9000008635	Fuse	1	350A
8	9000010657	Copper bar	1	
9	9000008586	Fuse base	1	BD-2X10A-1
10	1000434040	Plug fuse	2	10A
11	9000000002	Contactora holder	1	
12	9000010656	Copper bar	1	
13	9000007679	Programmer plug-in holder	1	
14	0000023516	Screw	3	M5x10
15	0000025015	Washer	3	5
16	0000025014	Washer	3	5
17	0000023211	Screw	6	M4x16
18	0000025018	Washer	6	4
19	0000025019	Washer	6	4
20	0000023019	Screw	2	M4x30
21	0000023307	Screw	6	M4x10
22	0090000395	Screw	2	M5x8
23	0000023166	Screw	1	M8x20
24	0000025005	Washer	1	8
25	0000025001	Washer	2	8
26	0000023089	Screw	2	M8x16
27	9000015362	Controller fixing plate	1	
28	9000010658	Controller assembly	1	

**Fig.39 Load backrest**

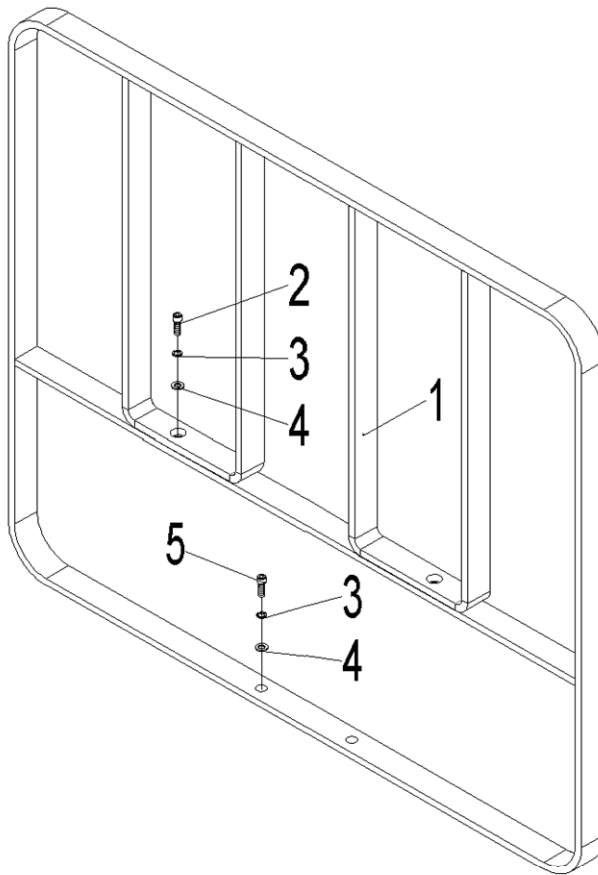

**Fig.38 Load Backrest**

No.	Art No.	Description	Qty.	Note
1	900008259	Load backrest	1	
2	0000023088	Screw	2	M10x25
3	0000025002	Washer	4	10
4	0000023006	Washer	4	10
5	0000023029	Screw	2	M10x35

**Fig.40 Load backrest (straddle)**

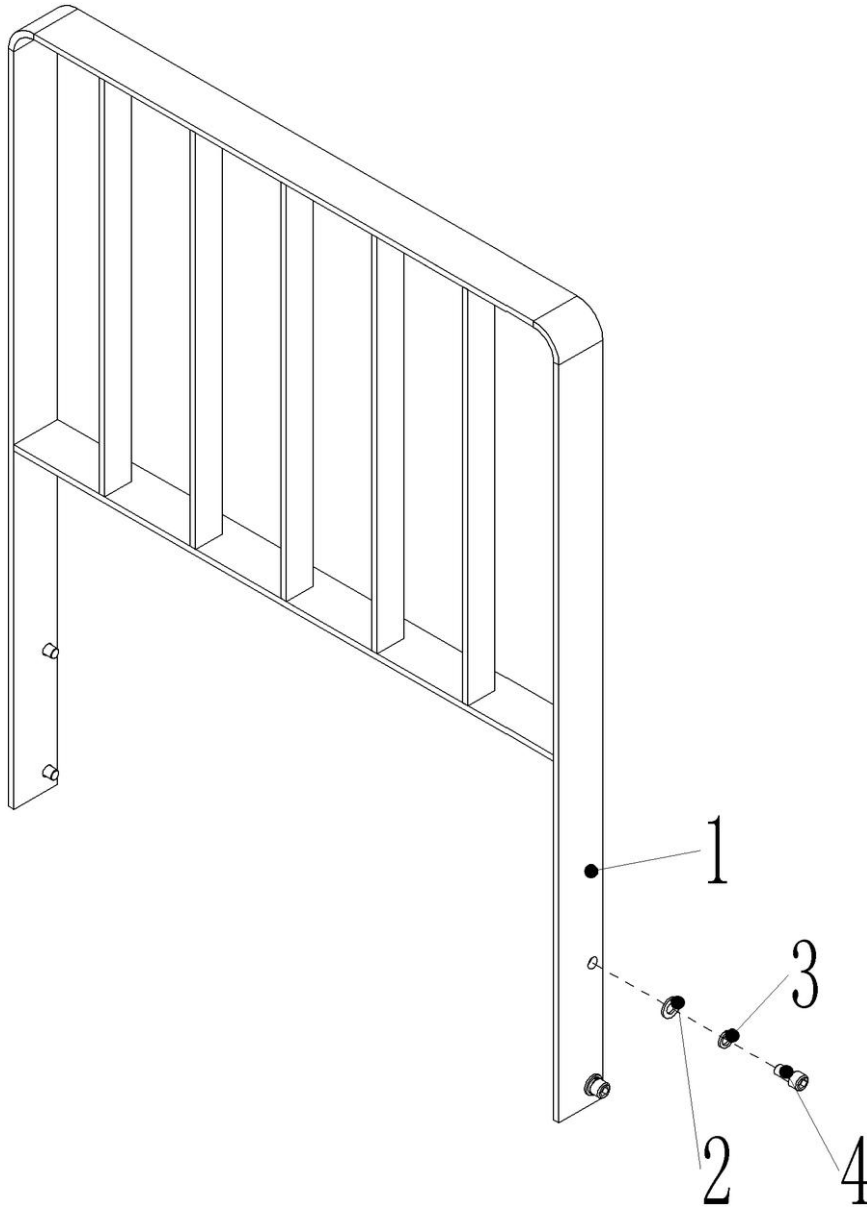

**Fig.39 Load backrest (straddle)**

No.	Art No.	Description	Qty.	Note
1	9000016305	Load backrest	1	
2	0000025024	Spring washer	4	12
3	0000025032	Washer	4	12
4	0000023156	Screw	4	M12x25

### Easy worn parts list

No.	Art No.	Description	Qty.	Fig./Position	Note
1	0000027013	Bearing	2	Fig.12/3	Steering wheel assembly
2	0000027001	Bearing	2	Fig.12/11	Steering wheel assembly
			8	Fig.33/5	Load wheel assembly
3	2210416001	Rear wheel	1	Fig.12/12	Steering wheel assembly
4	9000009926	Dust ring	1	Fig.26/2	Three-stage Mast outer Cylinder Assembly(full free lift)
			1	Fig.28/1	Three-stage Mast outer Cylinder Assembly(standard lift)
			1	Fig.31/1	Two-stage Mast outer Cylinder Assembly(standard lift)
5	9000009170	Y ring	1	Fig.26/3	Three-stage Mast outer Cylinder Assembly(full free lift)
			1	Fig.31/2	Two-stage Mast outer Cylinder Assembly(standard lift)
6	9000015671	Seal ring	1	Fig.26/4	Three-stage Mast outer Cylinder Assembly(full free lift)
			1	Fig.31/3	Two-stage Mast outer Cylinder Assembly(standard lift)
7	9000015668	Supporting ring	1	Fig.26/5	Three-stage Mast outer Cylinder Assembly(full free lift)
			1	Fig.28/3	Three-stage Mast outer Cylinder Assembly(standard lift)
8	9000015660	O ring	1	Fig.26/7	Three-stage Mast outer Cylinder Assembly(full free lift)
			1	Fig.29/6	Two-stage Mast outer Cylinder Assembly(full free lift)
			1	Fig.31/6	Two-stage Mast outer Cylinder Assembly(standard lift)
9	9000015661	Supporting ring	1	Fig.26/12	Three-stage Mast outer Cylinder Assembly(full free lift)
			1	Fig.29/13	Two-stage Mast outer Cylinder Assembly(full free lift)
			1	Fig.31/12	Two-stage Mast outer Cylinder Assembly(standard lift)
10	9000016329	Outer cylinder seal assembly	1	Fig.26/11	Three-stage Mast outer Cylinder Assembly(full free lift)
11	9000015662	Dust ring	1	Fig.27/2	Three-stage Mast middle Cylinder Assembly(full free lift)
			1	Fig.30/2	Two-stage Mast middle Cylinder Assembly(full free lift)

12	9000015663	Stop collar	1	Fig.27/3	Three-stage Mast middle Cylinder Assembly(full free lift)
			1	Fig.30/3	Two-stage Mast middle Cylinder Assembly(full free lift)
13	9000010181	Seal ring	1	Fig.27/4	Three-stage Mast middle Cylinder Assembly(full free lift)
			1	Fig.30/4	Two-stage Mast middle Cylinder Assembly(full free lift)
14	9000015664	O ring	1	Fig.27/6	Three-stage Mast middle Cylinder Assembly(full free lift)
			1	Fig.30/6	Two-stage Mast middle Cylinder Assembly(full free lift)
15	9000015665	Stop collar	1	Fig.27/7	Three-stage Mast middle Cylinder Assembly(full free lift)
			1	Fig.30/7	Two-stage Mast middle Cylinder Assembly(full free lift)
16	9000015666	Supporting ring	1	Fig.27/8	Three-stage Mast middle Cylinder Assembly(full free lift)
			1	Fig.30/8	Two-stage Mast middle Cylinder Assembly(full free lift)
17	9000015667	Supporting ring	1	Fig.27/13	Three-stage Mast middle Cylinder Assembly(full free lift)
			1	Fig.30/13	Two-stage Mast middle Cylinder Assembly(full free lift)
18	9000015674	Middle cylinder seal assembly	1	Fig.27/11	Three-stage Mast middle Cylinder Assembly(full free lift)
19	9000016328	O ring	1	Fig.28/9	Three-stage Mast outer Cylinder Assembly(standard lift)
20	9000009182	Supporting ring	1	Fig.28/10	
21	9000009178	Y ring	1	Fig.28/11	
22	9000016330	Outer cylinder seal assembly	1	Fig.28/11	
23	9000015669	Dust ring	1	Fig.29/1	
24	9000009708	Seal ring	1	Fig.29/2	Two-stage Mast outer Cylinder Assembly(full free lift)
25	9000009710	Seal ring	1	Fig.29/3	
26	9000009711	Supporting ring	1	Fig.29/4	
27	9000016331	Outer cylinder seal assembly	1	Fig.29/11	
28	9000015677	Middle cylinder seal assembly	1	Fig.30/11	
29	9000009927	Supporting ring	1	Fig.31/4	Two-stage Mast outer Cylinder Assembly(standard lift)
30	9000016332	Outer cylinder seal assembly	1	Fig.31/11	
31	1000507011	Load wheel	4	Fig.33/6	Load Wheel Assembly
32	9000010728	Load wheel	4	Fig.33/10	

		assembly			
33	9000008329	Proximity switch NBN5-F7-E2	2	Fig.34/7	Handle Assembly
34	9000011289	Air spring	1	Fig.34/10	
35	2040634001	Micro switch	1	Fig.37/4	Electrical general Part
36	9000008332	Magnet switch	2	Fig.37/7	
37	9000008635	Fuse	1	Fig.38/7	Controller Assembly
38	1000434040	Plug fuse	1	Fig.38/10	