

# SPAREPARTS LIST

## Electric Stacker PS35L

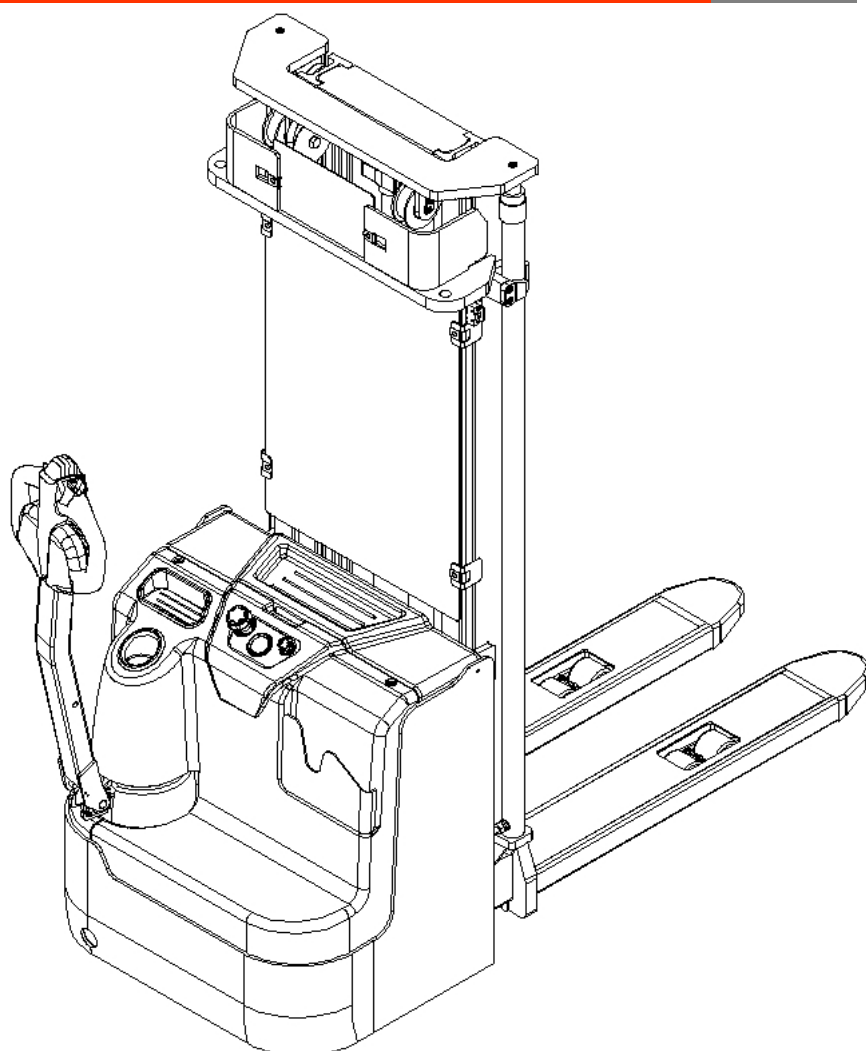

Version 02/2016

From truck identification number:

PS 16L-BPT-002-EN

# Catalogue

Fig.1 Label (for EU) .....	1
Fig.2 Label (for US) .....	2
Fig.3 Outline .....	3
Fig.4 Pallet .....	4
Fig.5 Fork assembly (straddle) .....	5
Fig.6 Truck assembly .....	6
Fig.7 Truck assembly(Side pull battery) .....	8
Fig.8 Truck assembly (straddle).....	10
Fig.9 Power supply .....	12
Fig.10 Indicator assembly.....	13
Fig.11 Battery cover assembly.....	15
Fig.12 Steering wheel assembly.....	16
Fig.13 Three-stage mast system (full free lift) .....	17
Fig.14 Three-stage mast system(standard lift).....	18
Fig.15 Two-stage mast system(full free lift).....	19
Fig.16 Two-stage mast system(standard lift) .....	20
Fig.17 Three-stage mast chain system(full free lift).....	21
Fig.18 Three-stage mast chain system(standard lift) .....	23
Fig.19 Two-stage mast chain system(full free lift).....	24
Fig.20 Two-stage mast chain system(standard lift).....	26
Fig.21 Mast and other parts.....	28
Fig.22 Three-stage mast hydraulic system(full free lift) .....	29
Fig.23 Three-stage mast hydraulic system(standard lift) .....	31
Fig.24 Two-stage mast hydraulic system(full free lift) .....	33
Fig.25 Two-stage mast hydraulic system(standard lift) .....	35
Fig.26 Three-stage mast outer cylinder assembly(full free lift) .....	37
Fig.27 Three-stage mast middle cylinder assembly(full free lift).....	39
Fig.28 Three-stage mast outer cylinder assembly(standard lift).....	41
Fig.29 Two-stage mast outer cylinder assembly(full free lift) .....	43
Fig.30 Two-stage mast middle cylinder assembly(full free lift).....	45
Fig.31 Two-stage mast outer cylinder assembly(standard lift).....	47
Fig.32 Drive system assembly .....	49
Fig.33 Load wheel assembly.....	50
Fig.34 Handle assembly .....	52
Fig.35 Pump system.....	53
Fig.36 Main circuit harness.....	54
Fig.37 Electrical general part .....	55
Fig.38 Controller assembly.....	56
Fig.39 Load backrest.....	58
Fig.40 Load backrest (straddle).....	59
Easy worn parts list.....	60

**Fig.1 Label (for EU)**

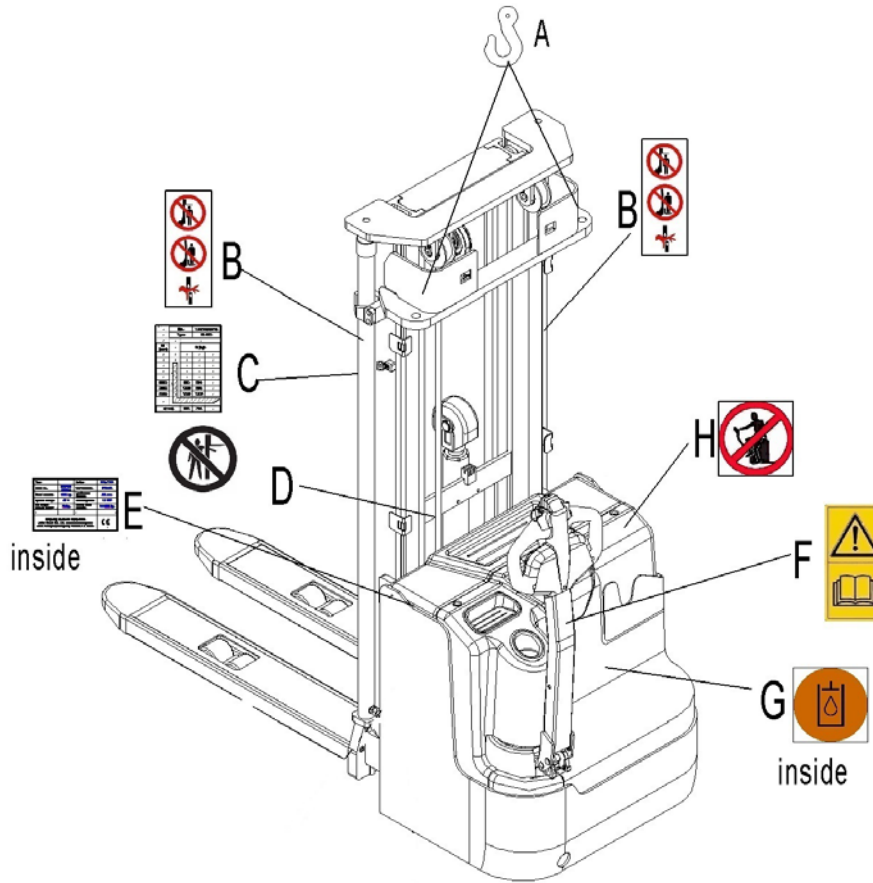

**Fig.1 Label (For EU)**

No.	Art No.	Description	Qty.	Note
A	9000005967	Crane hook label	2	
B	9000003923	Warning decal: Do not step under or on the forks	2	
C	9000015633	Residual lift capacity sticker	1	
D	9000008561	Never reach through	1	
E	9000015634	CE label	1	
F	9000003570	Sticker to read and follow these instructions	1	
G	9000008555	Filling sticker	1	
H	9000003573	'No passengers' decal	1	
O	9000008556	Emblem mark	2	

**Fig.2 Label (for US)**

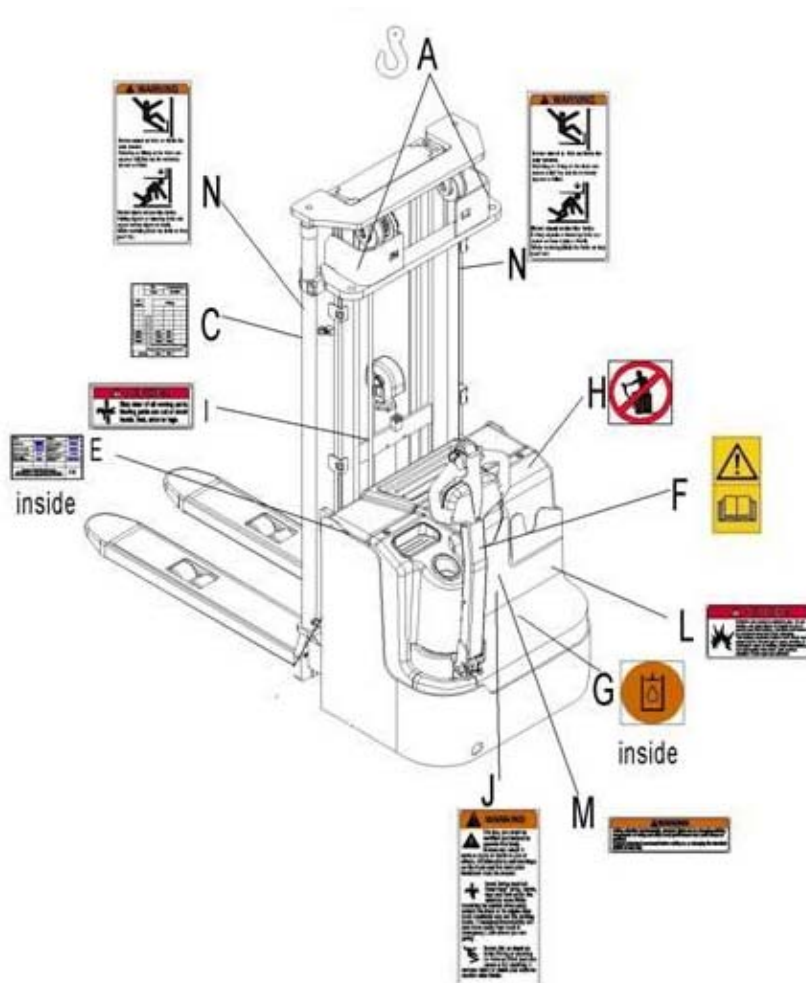

**Fig.2 Label (For US)**

No.	Art No.	Description	Qty.	Note
A	900005967	Crane hook label	2	
C	9000015633	Residual lift capacity sticker	1	
E	9000015634	CE label	1	
F	9000003570	Sticker to read and follow these instructions	1	
G	9000008555	Filling sticker	1	
I	9000005970	Warning label	1	
J	9000003575	Warning label	1	
K	9000003580	Warning label	1	
L	9000003577	Warning label	1	
M	9000003579	Warning label	1	
N	9000005971	Warning label	2	

**Fig.3 Outline**

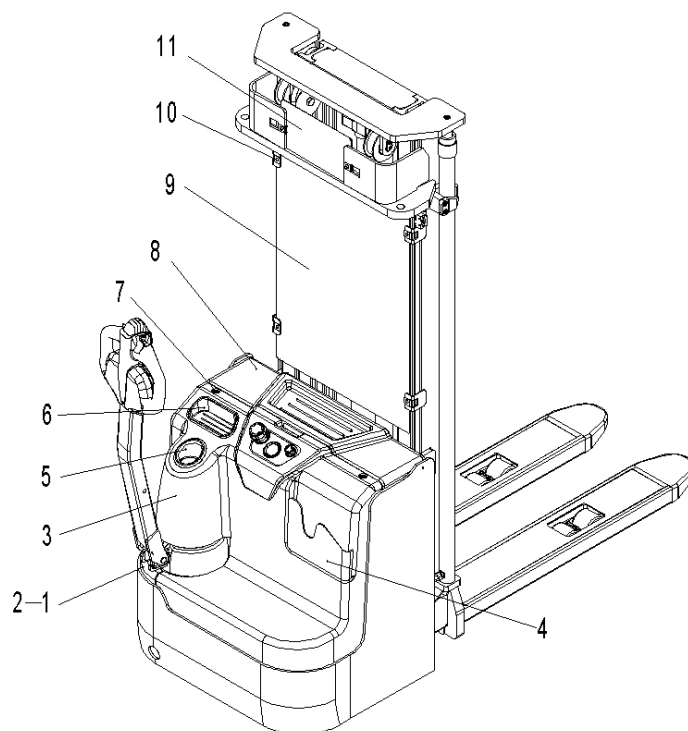

**Fig.3 Outline**

No.	Art No.	Description	Qty.	Note
1	9000015364	Cover	1	
2	0000023093	Screw	2	M6x10
3	9000015363	Electrical box cover	1	
4	9000010660	File box	1	
5	9000015365	Cup base	1	
6	9000015366	Storage box	1	
7	9000007790	Screw	2	M10X55
9	9000015332	Protective plate	1	(4600)
	9000015403	Protective plate	1	(5300)
	9000015391	Protective plate	1	(4300)
	9000015415	Protective plate	1	(4000)
	9000015192	Protective plate	1	(3600)
	9000015195	Protective plate	1	(2900)
10	9000007782	Spring buckle	6	
11	9000015331	Upper protective plate	1	

**Fig.4 Pallet**

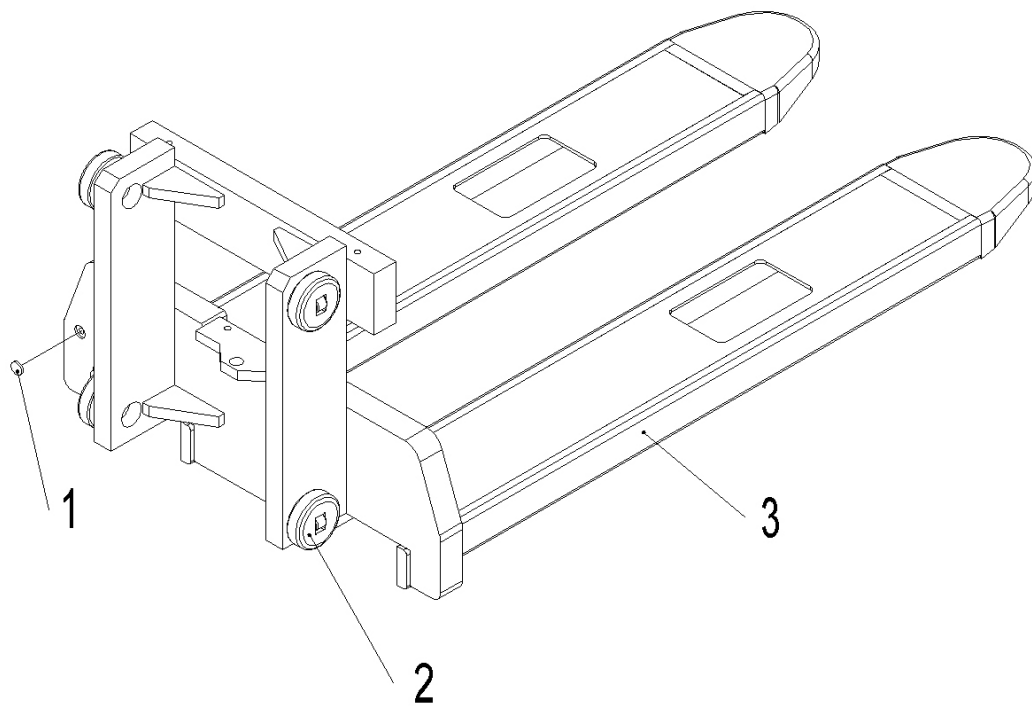

**Fig.4 Pallet**

No.	Art No.	Description	Qty.	Note
1	2000435002	Magnet steel	1	
2	2330511001	Roller	4	1
3	9000015420	Pallet (570×1150)	1	Three- stage mast FFL
	9000015444	Pallet (685×1150)	1	Three- stage mast FFL
	9000015278	Pallet (570×1150)	1	Three-stage mast standard
	9000015290	Pallet (685×1150)	1	Three- stage mast standard
	9000015231	Pallet (570×1150)	1	Two-stage mast FFL
	9000015246	Pallet (685×1150)	1	Two-stage mast FFL
	9000015198	Pallet (570×1150)	1	Two-stage mast standard
	9000015207	Pallet (685×1150)	1	Two-stage mast standard

**Fig.5 Fork assembly (straddle)**

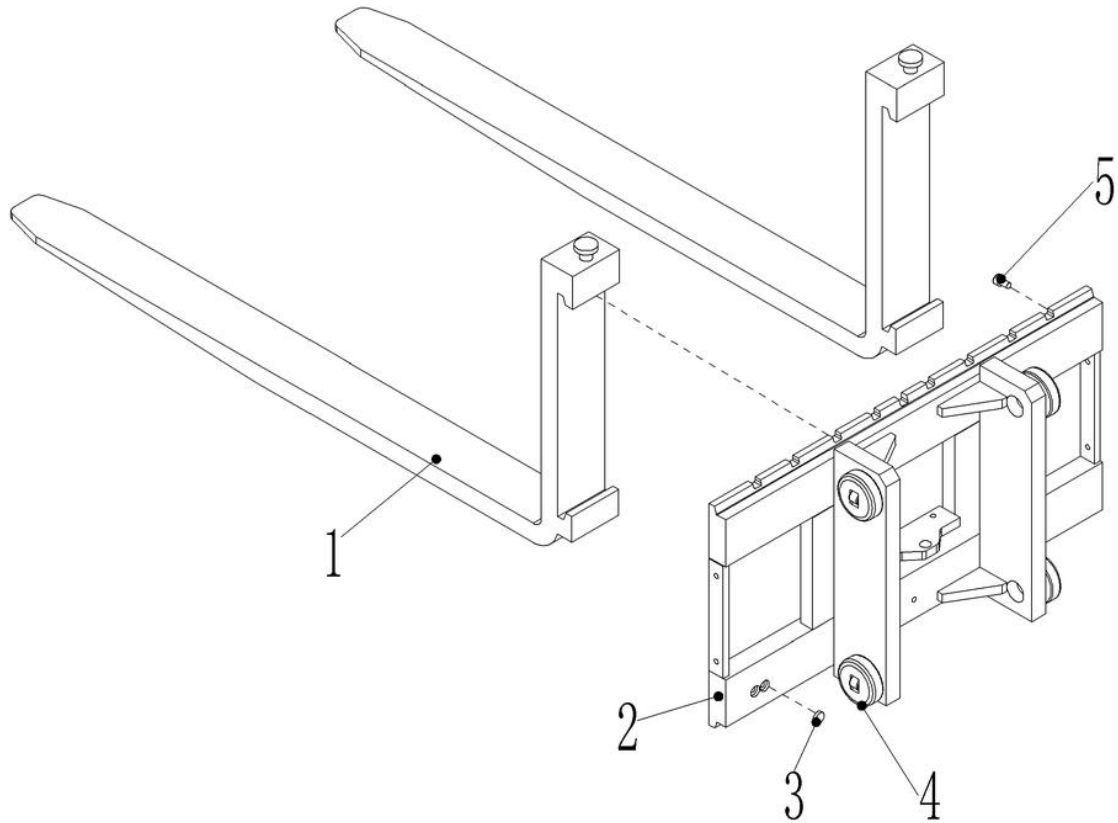

**Fig.5 Fork Assembly (straddle)**

No.	Art No.	Description	Qty.	Note
1	9000017399	Fork assembly (hook type)	2	Width: 120
2	9000016298	Fork frame assembly	1	Three-stage-mast (full free lift)
	9000016277			Three-stage-mast (standard)
	9000016274			Two-stage-mast (full free lift)
	9000016270			Two-stage-mast (standard)
3	2000435002	Magnet steel	1	
4	2330511001	Roller 1	4	
5	0000023080	Screw	2	M10x16

**Fig.6 Truck assembly**

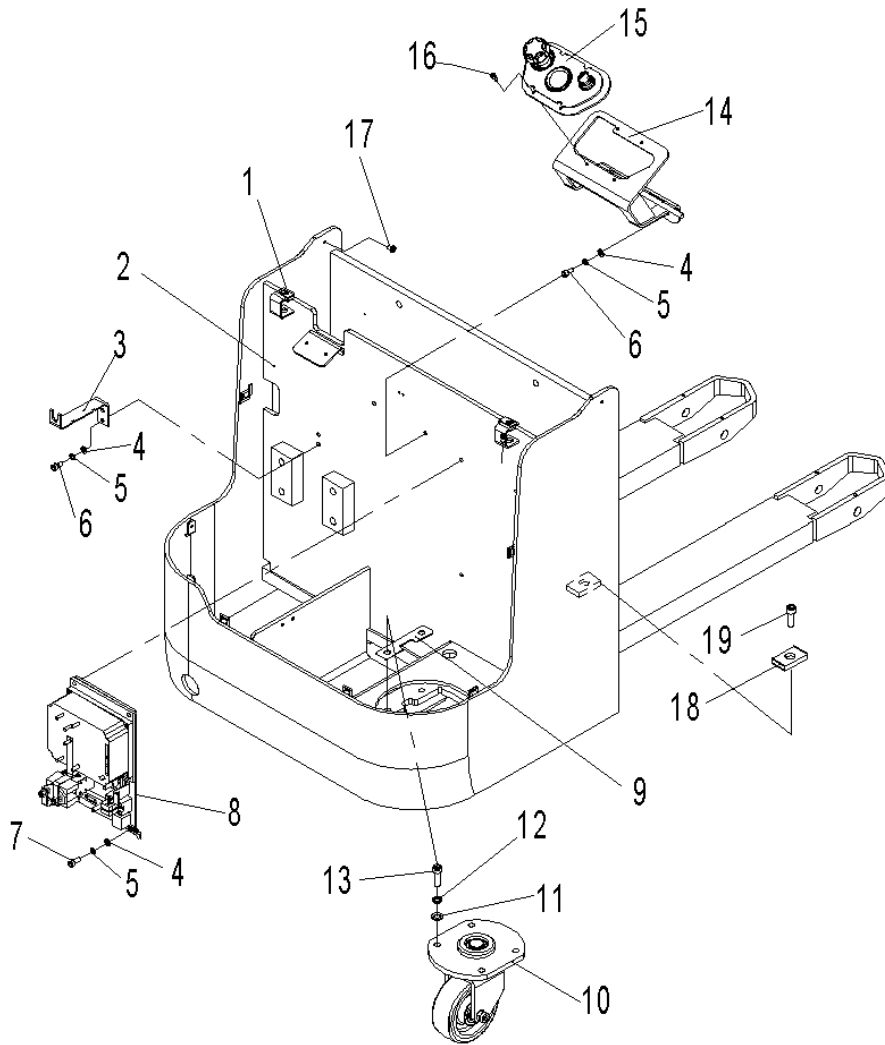
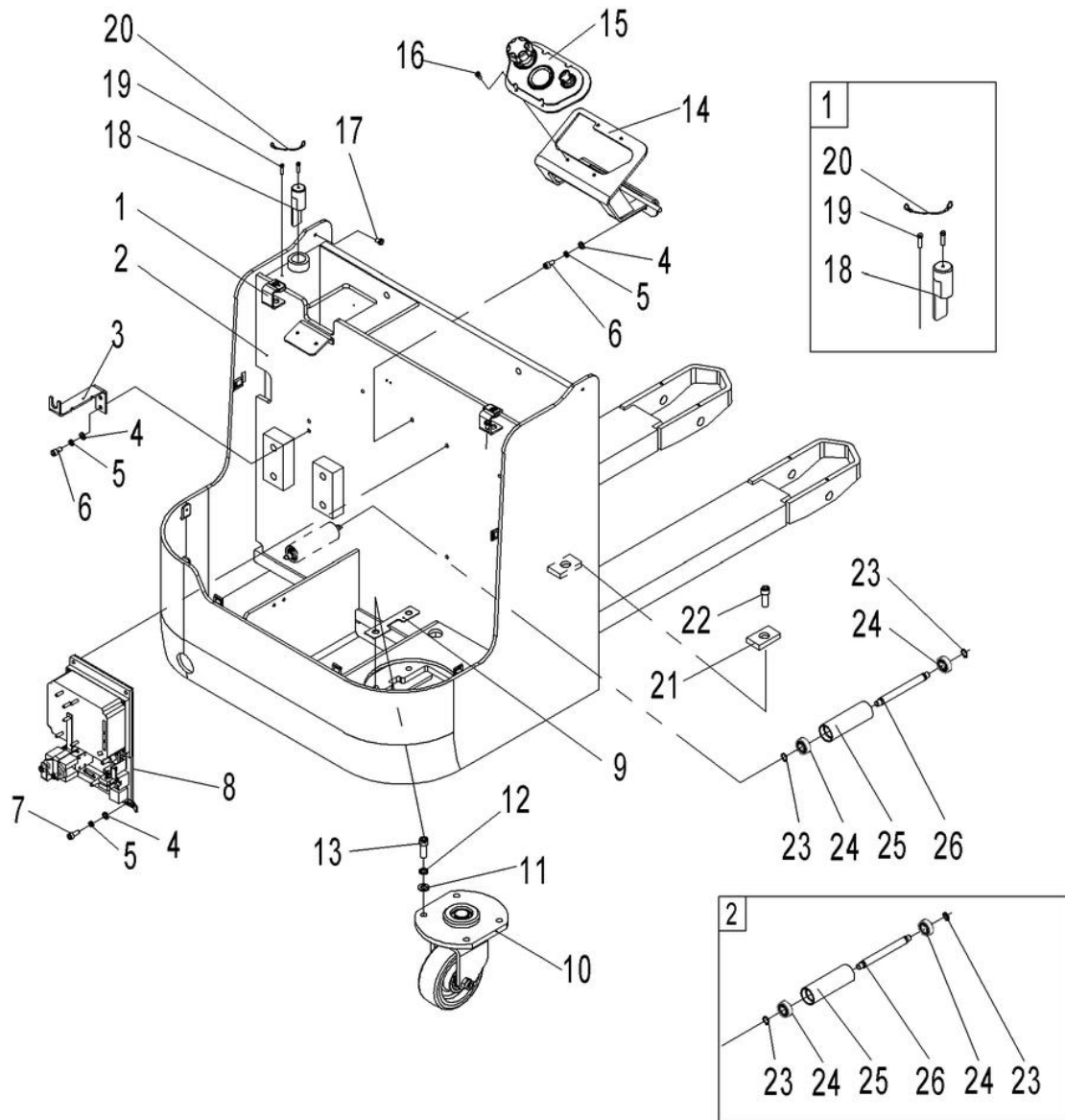



**Fig.6 Truck Assembly**

No.	Art No.	Description	Qty.	Note
1	9000007783	Nut	2	M10
2	9000015428	Truck body	1	(570X1150)
	9000015464	Truck body	1	(685X1150)
3	9000015356	Cable holder	1	
4	0000025011	Washer	8	8
5	0000025001	Washer	8	8
6	0000023067	Screw	4	M8x16
7	0000023061	Screw	4	M8x25
8	9000015362	Controller fixing plate	1	
9	9000015361	Steering wheel pad	6	
10	9000015432	Steering wheel assembly	1	
11	0000025032	Washer	4	12
12	0000025024	Washer	4	12
13	0000023082	Screw	4	M12x35
14	9000015430	Fixing plate	1	
15	9000015431	Instrument assembly	1	
16	0000023020	Screw	4	M6x20
17	9000015369	Locating sleeve	2	
18	9000015373	Cushion	2	
19	0000023045	Screw	2	M6x12

**Fig.7 Truck assembly(Side pull battery)**



**Fig.7 Truck Assembly(Side pull battery)**

No.	Art No.	Description	Qty.	Note
1	9000007783	Nut	2	M10
2	9000017402	Truck body	1	(570X1150)
	9000017416	Truck body	1	(685X1150)
3	9000015356	Cable holder	1	
4	0000025011	Washer	8	8
5	0000025001	Washer	8	8
6	0000023067	Screw	4	M8x16
7	0000023061	Screw	4	M8x25
8	9000015362	Controller fixing plate	1	
9	9000015361	Steering wheel pad	6	
10	9000015432	Steering wheel assembly	1	
11	0000025032	Washer	4	12
12	0000025024	Washer	4	12
13	0000023082	Screw	4	M12x35
14	9000015430	Fixing plate	1	
15	9000015431	Instrument assembly	1	
16	0000023020	Screw	4	M6x20
17	9000015369	Locating sleeve	2	
18	9000017412	Lock shaft	1	
19	9000017413	Short connecting rod	2	
20	9000017414	Wirerope	1	
21	9000015373	Cushion	2	
22	0000023045	Screw	2	M6x12
23	0000026004	Circlip	12	15
24	0000027060	Bearing	12	6202
25	9000017410	Barrel	6	
26	9000017409	Axle	6	
①	9000017411	Lock shaft assembly	1	
②	9000017408	Roller assembly	6	

**Fig.8 Truck assembly (straddle)**

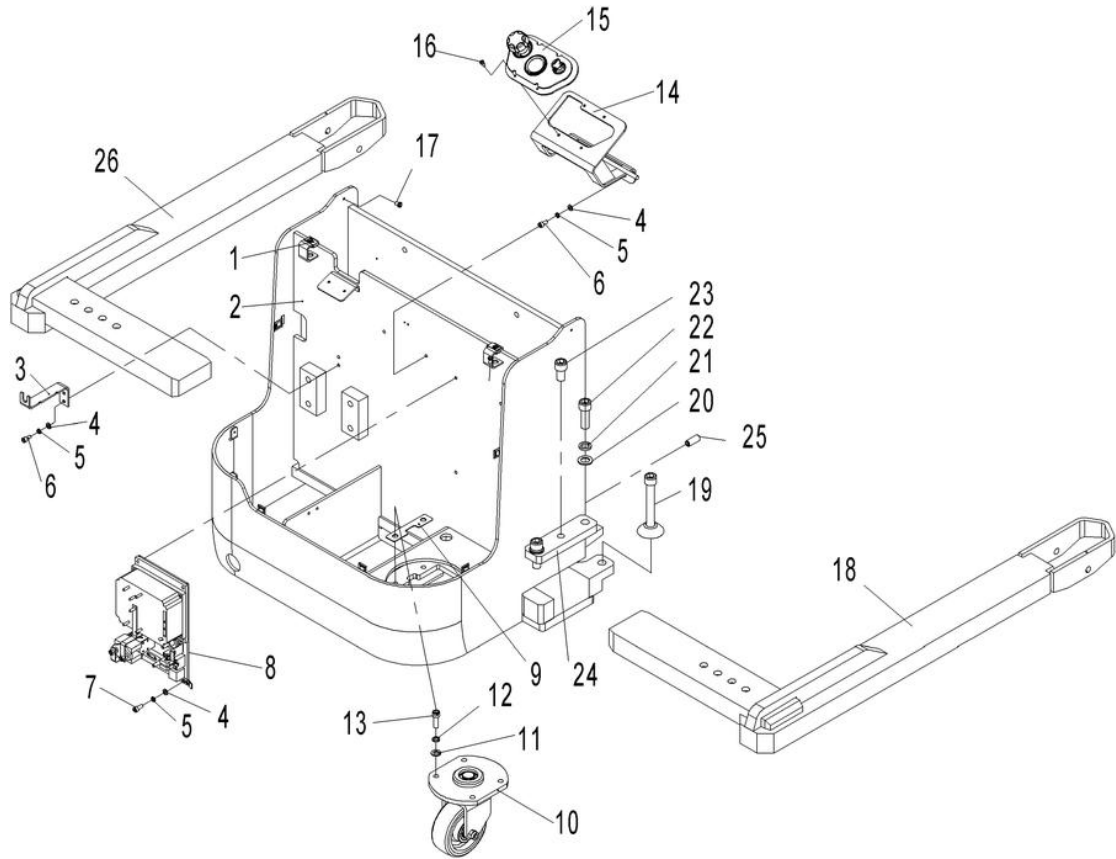

**Fig.7 Truck Assembly (straddle)**

No.	Art No.	Description	Qty.	Note
1	9000007783	Nut	2	M10
2	9000016300	Truck assembly	1	
3	9000015356	Cable holder	1	
4	0000025011	Washer	8	8
5	0000025001	Spring washer	8	8
6	0000023067	Screw	4	M8x16
7	0000023061	Screw	4	M8x25
8	9000015362	Controller fixing plate	1	
9	9000015361	Steering wheel pad	6	
10	9000015432	Steering wheel	1	
11	0000025032	Washer	4	12
12	0000025024	Spring washer	4	12
13	0000023082	Screw	4	M12x35
14	9000015430	Fixing plate	1	
15	9000015431	Instrument	1	
16	0000023020	Screw	4	M6x20
17	9000015369	Locating sleeve	2	
18	9000016303	Right front leg	1	
19	2050402002	Supporting assembly	2	
20	0000025031	Washer	4	20
21	0000025033	Spring washer	4	20
22	0000023453	Screw	4	M20x60
23	2050402003	Locating pin	2	
24	9000016290	Pressure plate	2	
25	0090000758	Lock screw	6	M16x40
26	9000016301	Left front leg	1	

**Fig.9 Power supply**

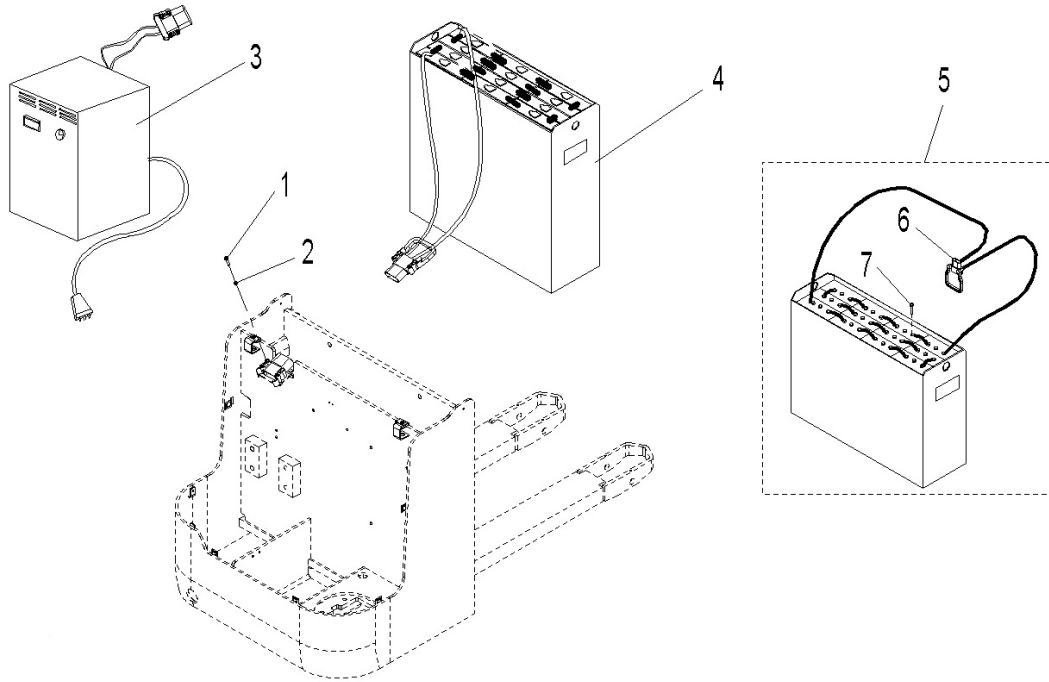

**Fig.8 Power Supply**

No.	Art No.	Description	Qty.	Note
1	0000023106	Screw	2	M6×30
2	0000023055	Washer	2	6
3	9000010147	Charger (Asian in Chinese)	1	24V/45A
	9000010148	Charger (Asian in English)		24V/45A
	9000010194	Charger (European)		24V/45A
	9000010195	Charger (Australian)		24V/45A
	9000010196	Charger (British)		24V/45A
	9000010197	Charger (American)		24V/45A
4	9000015441	Power assembly-welded	1	270Ah
5	9000015465	Power assembly - bolted	1	270Ah
6	2000434002	Connector assembly	1	Only for bolt type battery
7	9000009832	Screw M10X22	24	

**Fig.10 Indicator assembly**

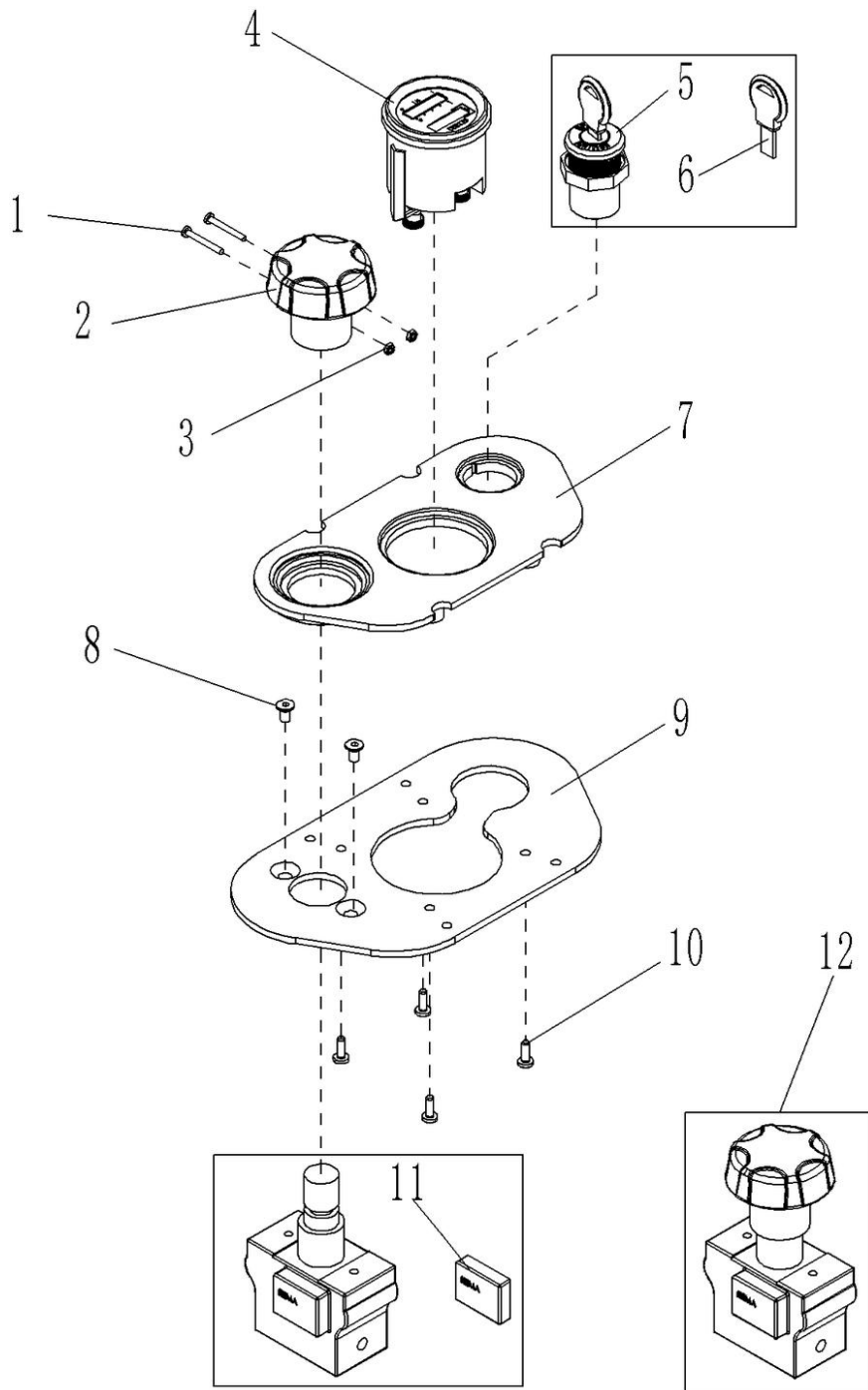
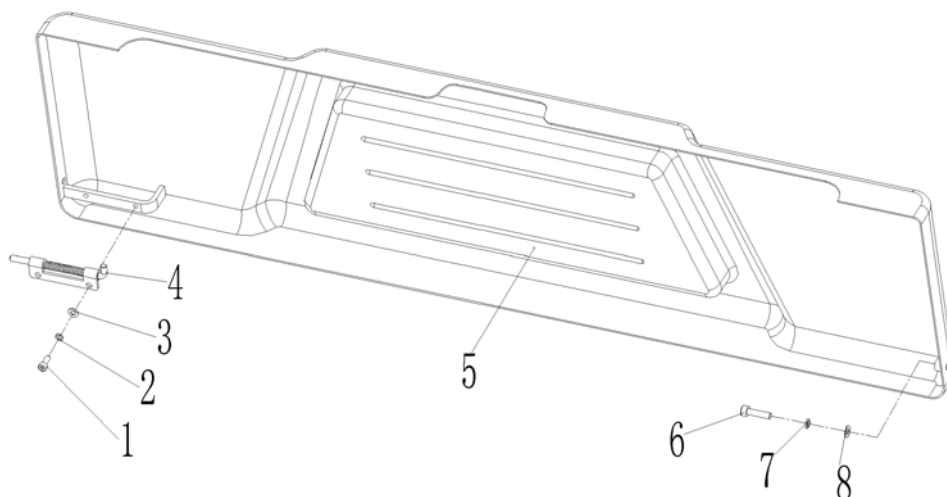

**Fig.9 Indicator Assembly**

No.	Art No.	Description	Qty.	Note
1	0000023685	Screw	2	M3×25
2	9000008516	DC power switch-mushroom cap	1	ZDK32-350
3	0000024002	Nut	2	M3
4	9000000760	Indicator	1	MDI CAN
5	9000008326	Key switch	1	LKS-101A
6	9000008519	Key switch-key	1	LKS-101A
7	9000015354	Integration leaf panel	1	
8	0000023215	Screw	2	M5×10
9	9000015355	Instrument fixing plate	1	
10	0090000272	Lock screw	4	M4×12
11	9000008517	DC power switch-micro switch	1	ZDK32-350
12	9000008515	DC power switch	1	ZDK32-350



**Fig.11 Battery cover assembly**



**Fig.10 Battery Cover Assembly**

No.	Art No.	Description	Qty.	Note
1	0000023073	Screw	2	M4×10
2	0000025018	Washer	2	4
3	0000025019	Washer	2	4
4	9000008795	Latch	1	
5	9000015436	Battery cover	1	
6	0000023306	Screw	1	M5×20
7	0000025015	Washer	1	5
8	0000025014	Washer	1	5

**Fig.12 Steering wheel assembly**

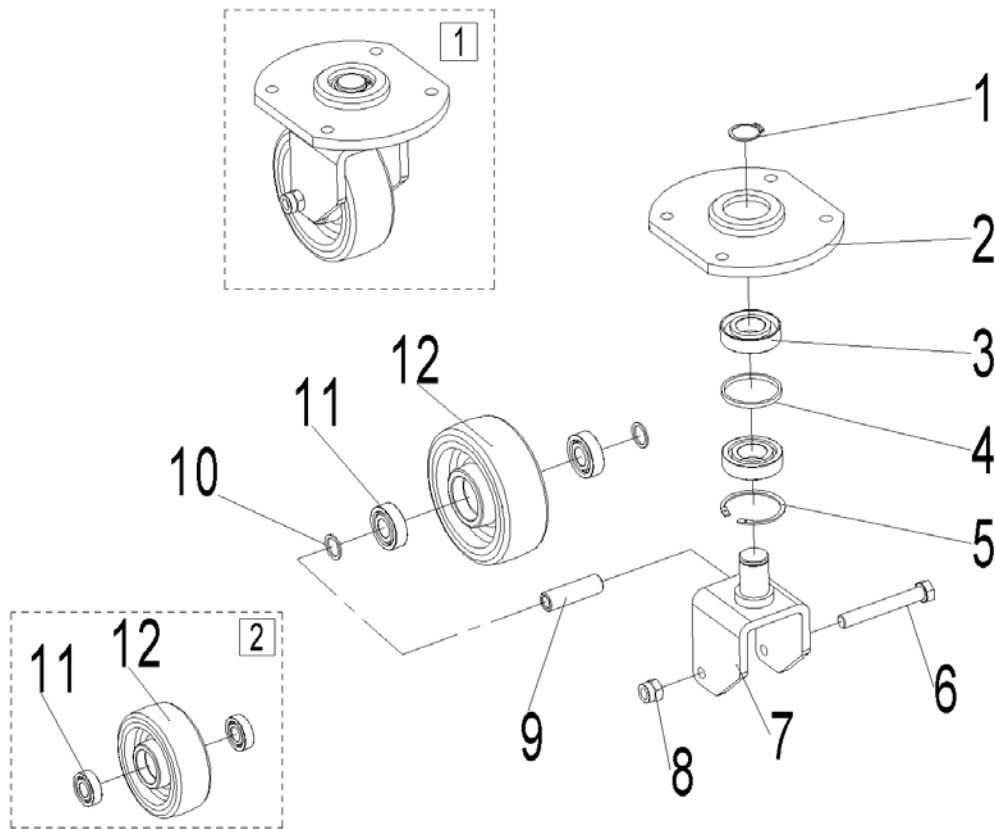

**Fig.11 Steering Wheel Assembly**

No.	Art No.	Description	Qty.	Note
1	0000026008	Circlip	1	30
2	9000015433	Bearing seat	1	
3	0000027013	Bearing	2	7206C/DB
4	2000413001	Bushing	1	
5	0000026010	Circlip	1	62
6	0000023111	Bolt	1	M14x100
7	9000015434	Rear wheel carrier	1	
8	0000024015	Lock nut	1	M14
9	2000413002	Bushing	1	
10	1000525001	Washer	2	
11	0000027001	Bearing	2	6204
12	2210416001	Rear wheel	1	
①	9000015432	Steering wheel assembly	1	
②	9000008896	Wheel set	1	

**Fig.13 Three-stage mast system (full free lift)**

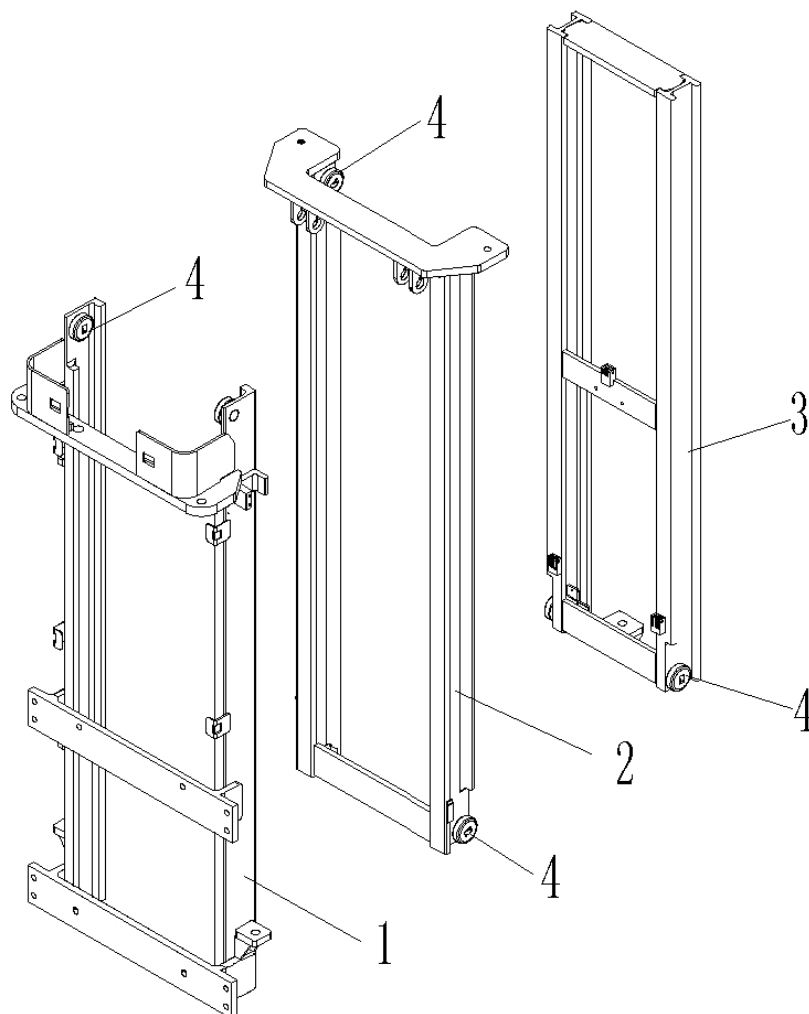

**Fig.12 Three-stage Mast System(full free lift)**

No.	Art No.	Description	Qty.	Note
1	9000015422	Mast	1	(4600)
	9000015446	Mast	1	(4300)
	9000015452	Mast	1	(5300)
	9000015458	Mast	1	(4000)
2	9000015423	Mast	1	(4600)
	9000015447	Mast	1	(4300)
	9000015453	Mast	1	(5300)
	9000015459	Mast	1	(4000)
3	9000015424	Mast	1	(4600)
	9000015448	Mast	1	(4300)
	9000015454	Mast	1	(5300)
	9000015460	Mast	1	(4000)
4	2040511001	Roller	8	1

**Fig.14 Three-stage mast system(standard lift)**

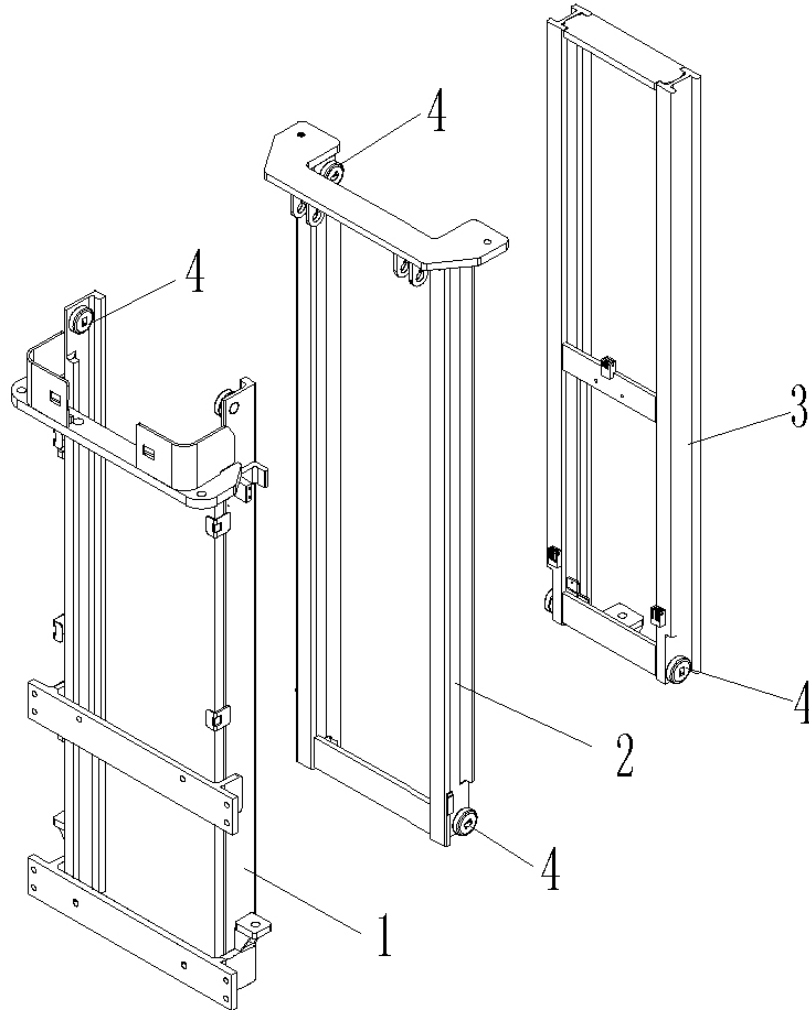

**Fig.13 Three-stage Mast System(standard lift)**

No.	Art No.	Description	Qty.	Note
1	9000015280	Mast	1	(4600)
	9000015292	Mast	1	(4300)
2	9000015281	Mast	1	(4600)
	9000015293	Mast	1	(4300)
3	9000015284	Mast	1	(4600)
	9000015294	Mast	1	(4300)
4	2040511001	Roller	8	1

**Fig.15 Two-stage mast system(full free lift)**

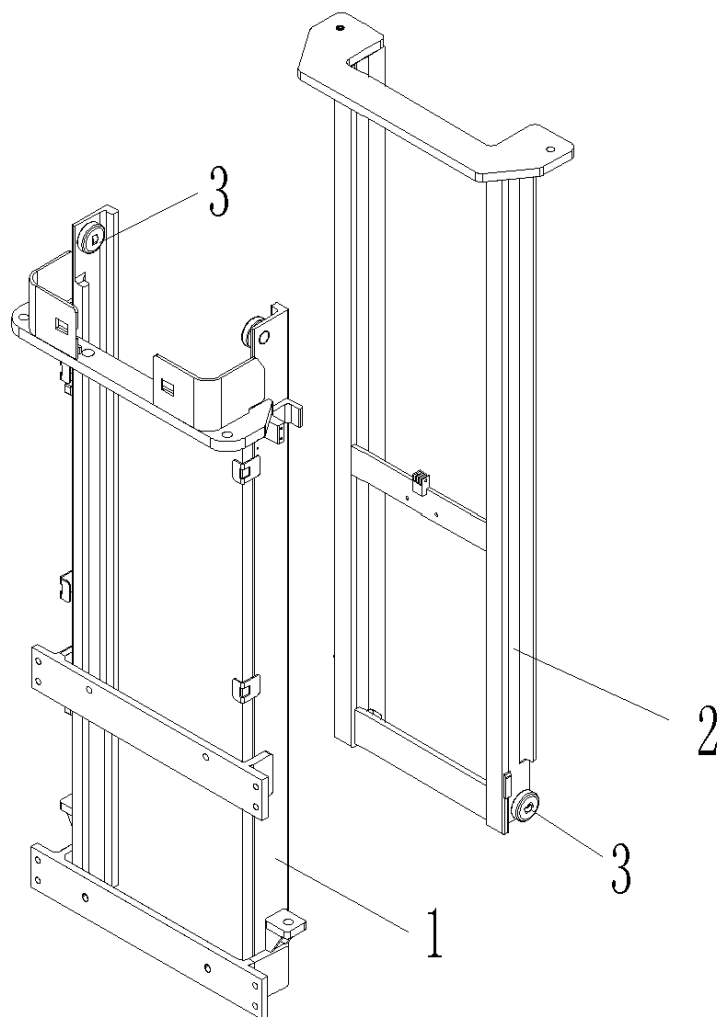

**Fig.14 Two-stage Mast System(full free lift)**

No.	Art No.	Description	Qty.	Note
1	9000015233	Mast	1	(3600)
	9000015248	Mast	1	(3200)
	9000015257	Mast	1	(2900)
2	9000015234	Mast	1	(3600)
	9000015249	Mast	1	(3200)
	9000015258	Mast	1	(2900)
3	2040511001	Roller	4	1

**Fig.16 Two-stage mast system(standard lift)**

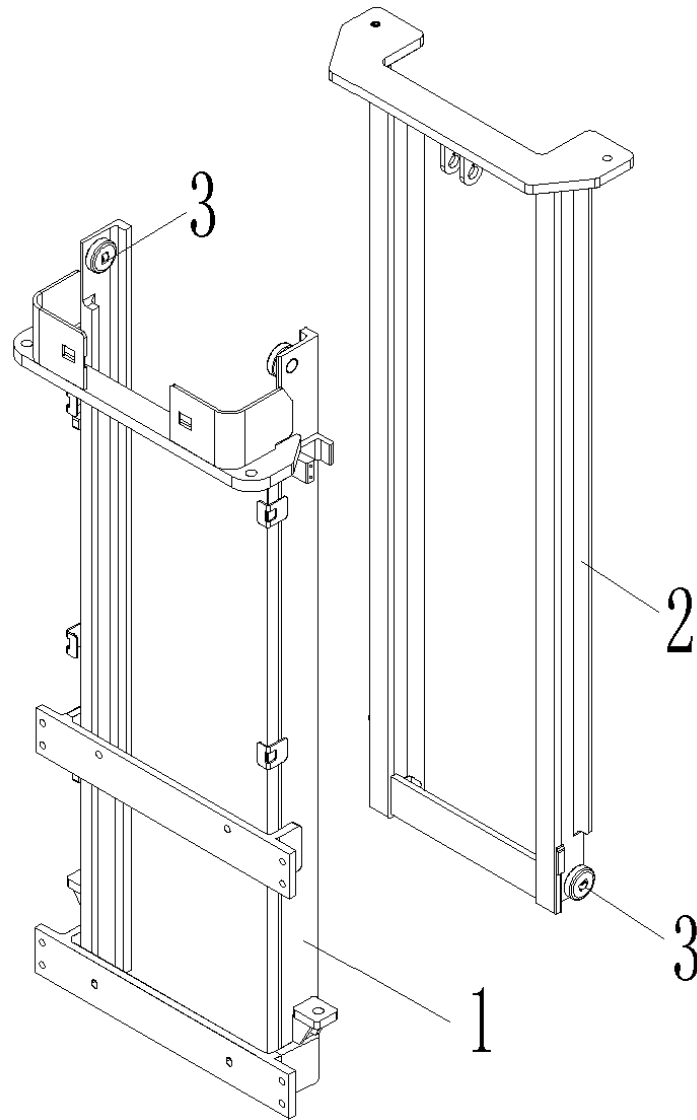

**Fig.15 Two-stage Mast System(standard lift)**

No.	Art No.	Description	Qty.	Note
1	9000015200	Mast	1	(3600)
	9000015209	Mast	1	(3200)
	9000015214	Mast	1	(2900)
2	9000015201	Mast	1	(3600)
	9000015210	Mast	1	(3200)
	9000015215	Mast	1	(2900)
3	2040511001	Roller	4	1

Fig.17 Three-stage mast chain system(full free lift)

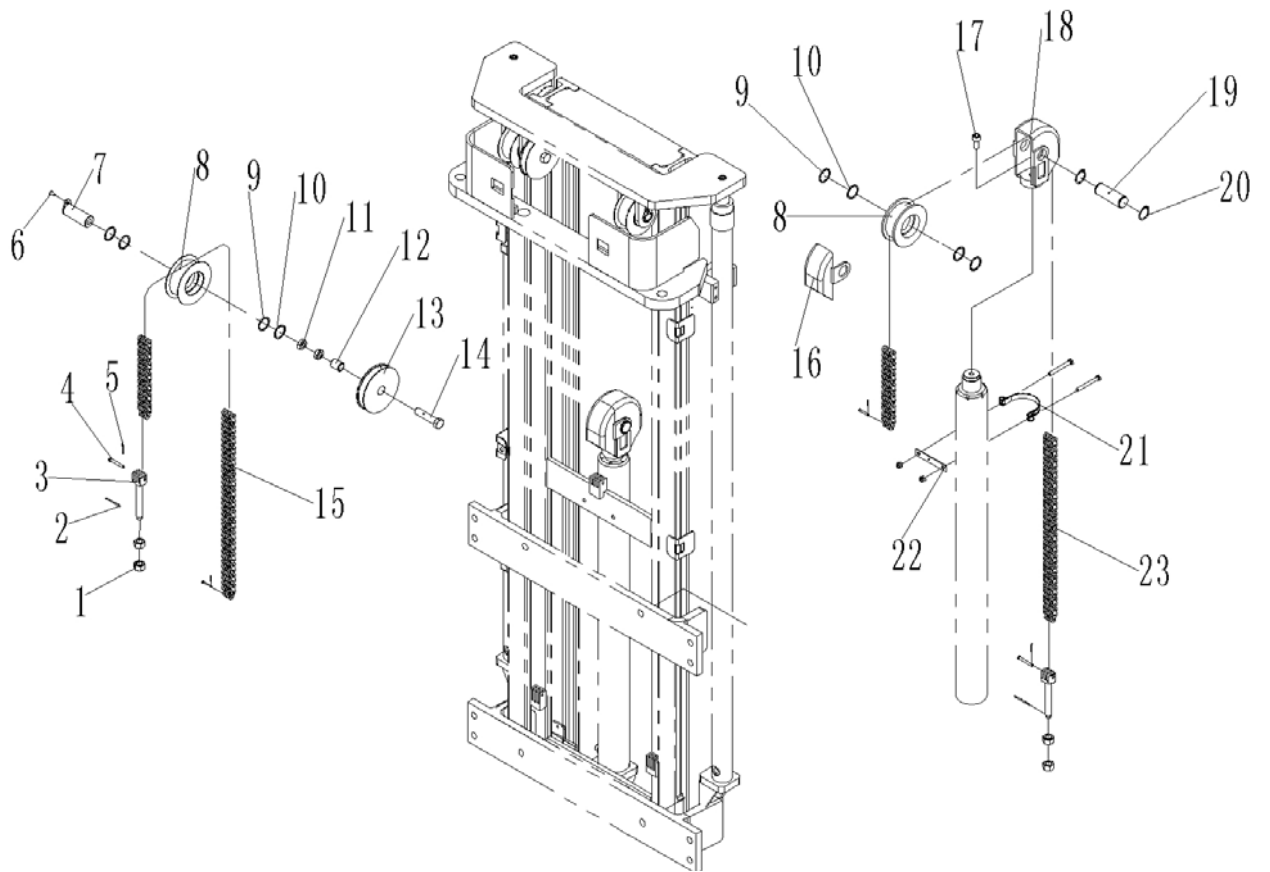
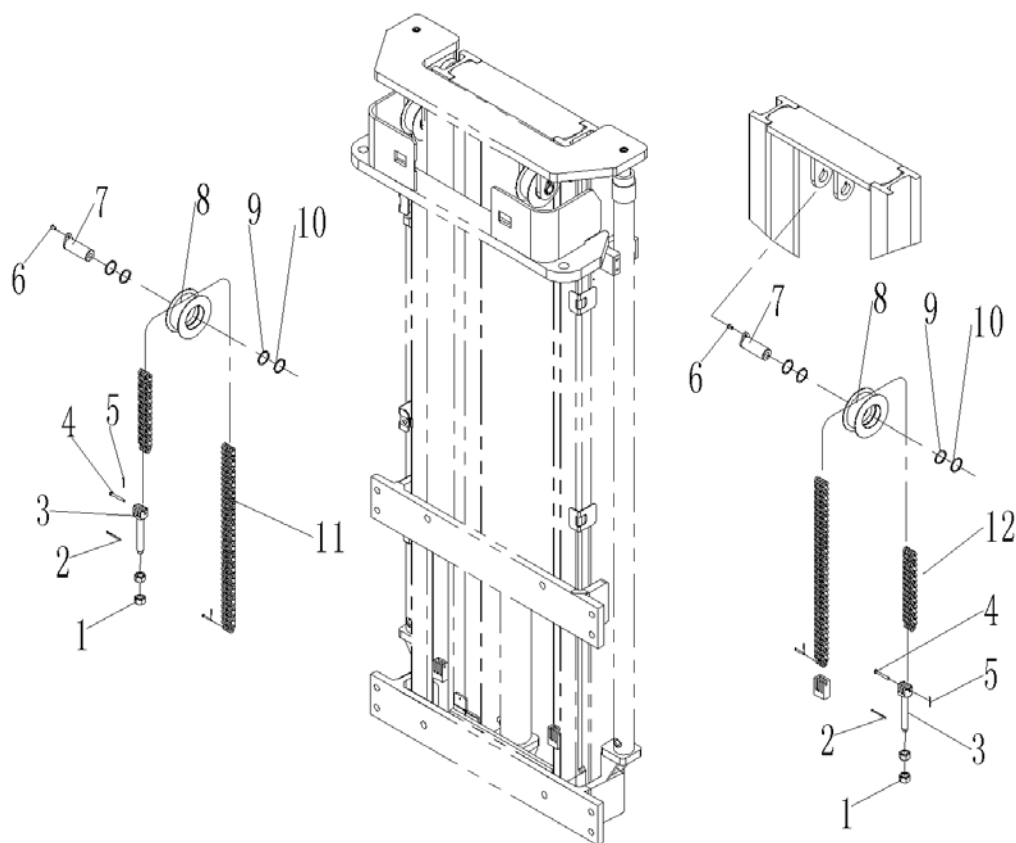

**Fig.16 Three-stage Mast Chain System(full free lift)**

No.	Art No.	Description	Qty.	Note
1	0090000442	Nut	6	M16x1.5
2	0000028011	Split pin	3	3x40
3	9000008260	Bolt	3	
4	0000028030	Short axle	6	6x45
5	0000028010	Split pin	6	2x20
6	0000023091	Screw	2	M6x12
7	9000009130	Chain wheel axle	2	
8	9000015636	Chain wheel for mast	3	
9	2000302002	Adjusting washer	6	(thickness 2)
10	9000015670	Adjusting washer	6	(thickness 4)
11	0000024010	Nut	2	M16
12	9000008245	Bearing bushing	1	
13	9000008246	Pulley	1	
14	0000023123	Bolt	1	M16x70
15	0090000661	Chain LH1066x125	2	4600
	0090000541	Chain LH1066x119	2	4300
	0090000452	Chain LH1066x139	2	5300
	0000029235	Chain LH1066x111	2	4000
16	2230305002	Side cover	1	
17	0000023156	Screw	1	M12x25
18	2230305001	Chain wheel seat	1	
19	2230307001	Chain wheel axle	1	
20	0000026008	Circlip	2	30
21	9000009831	Hoop assembly	1	center distance 96
22	9000015319	Middle cylinder pad	1	
23	0090000483	Chain LH1066x75	1	4600
	0090000539	Chain LH1066x73	1	4300
	0090000830	Chain LH1066x83	1	5300
	0000029067	Chain LH1066x69	1	4000



**Fig.18 Three-stage mast chain system(standard lift)**



**Fig.17 Three-stage mast chain system(standard lift)**

No.	Art No.	Description	Qty.	Note
1	0090000442	Nut	6	M16x1.5
2	0000028011	Split pin	3	3x40
3	9000008260	Bolt	3	
4	0000028030	Short axle	6	6x45
5	0000028010	Split pin	6	2x20
6	0000023091	Screw	3	M6x12
7	9000009130	Chain wheel axle	3	
8	9000015636	Chain wheel for mast	3	
9	2000302002	Adjusting washer	6	(thickness 2)
10	9000015670	Adjusting washer	6	(thickness 4)
11	0090000661	Chain LH1066x125	2	4600
	0090000541	Chain LH1066x119	2	4300
12	0090000541	Chain LH1066x119	1	4600
	0000029235	Chain LH1066x111	1	4300

**Fig.19 Two-stage mast chain system(full free lift)**

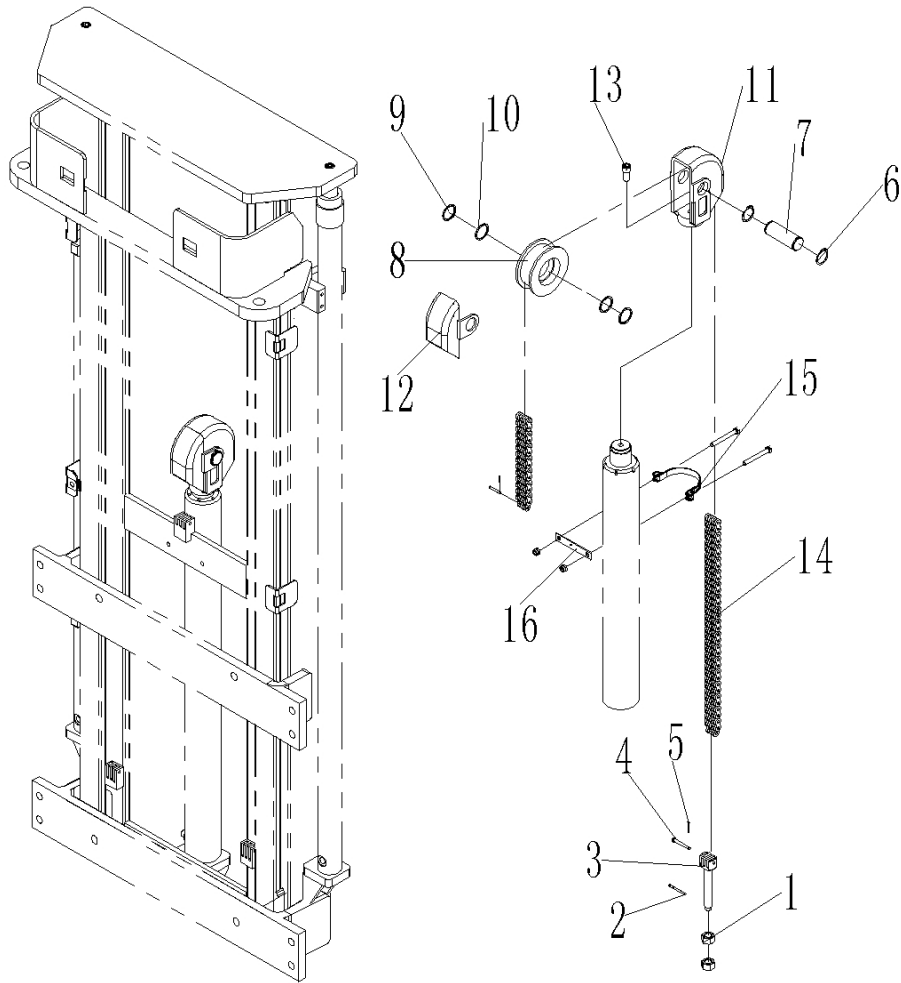

**Fig.18 Two-stage Mast Chain System(full free lift)**

No.	Art No.	Description	Qty.	Note
1	0090000442	Nut	2	M16x1.5
2	0000028011	Split pin	1	3x40
3	9000008260	Bolt	1	
4	0000028030	Short axle	2	6x45
5	0000028010	Split pin	2	2x20
6	0000026008	Circlip	2	30
7	2230307001	Sprocket shaft	1	
8	9000015636	Chain wheel for mast	1	
9	2000302002	Adjusting washer	2	( thickness 2 )
10	9000015670	Adjusting washer	2	( thickness 4 )
11	2230305002	Side cover	1	
12	2230305001	Chain wheel seat	1	
13	0000023156	Screw	1	M12x25
14	0000029056	Chain LH1066x81	1	3600
	0090000483	Chain LH1066x75	1	3200
	0090000482	Chain LH1066x71	1	2900
15	9000009831	Hoop assembly	1	center distance 96
16	9000015319	Middle cylinder pad	1	

**Fig.20 Two-stage mast chain system(standard lift)**

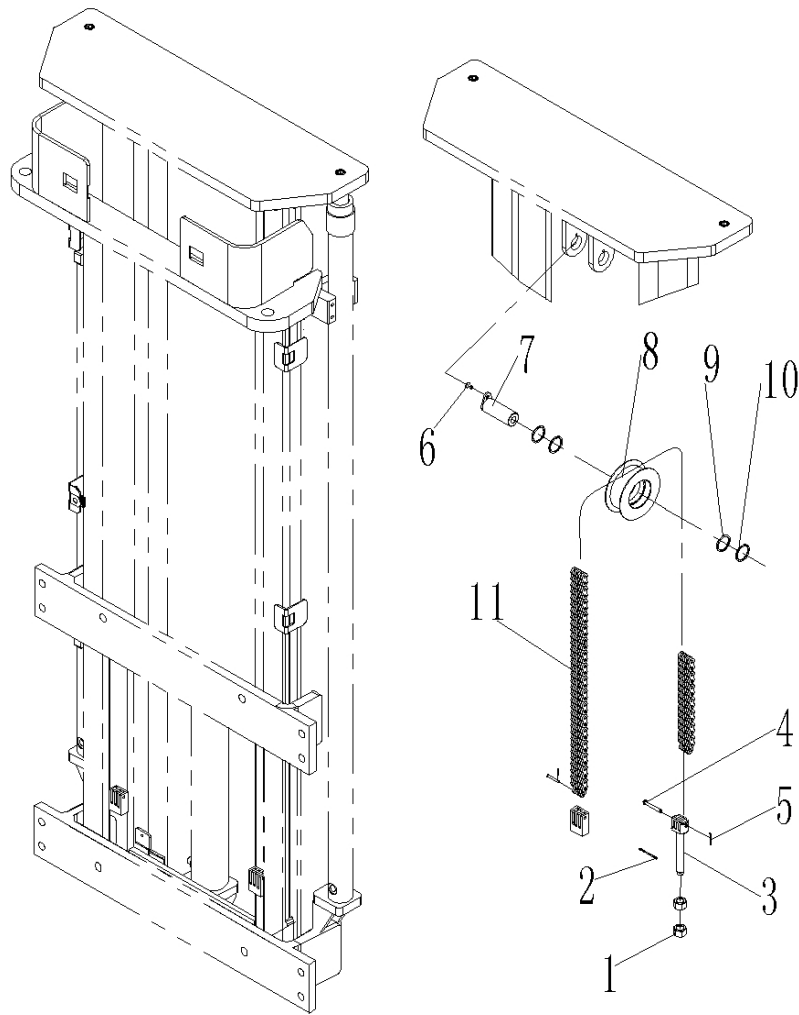

**Fig.19 Two-stage Mast Chain System(standard lift)**

No.	Art No.	Description	Qty.	Note
1	0090000442	Nut	2	M16x1.5
2	0000028011	Split pin	2	3x40
3	9000008260	Bolt	1	
4	0000028030	Short axle	2	6x45
5	0000028010	Split pin	1	2x20
6	0000023091	Screw	1	M6x12
7	9000009130	Chain wheel shaft	1	
8	9000015636	Chain wheel for mast	1	
9	2000302002	Adjusting washer	2	(thickness 2)
10	9000015670	Adjusting washer	2	(thickness 4)
11	0090000661	Chain LH1066x137	1	3600
	0090000661	Chain LH1066x125	1	3200
	0090000435	Chain LH1066x115	1	2900

**Fig.21 Mast and other parts**

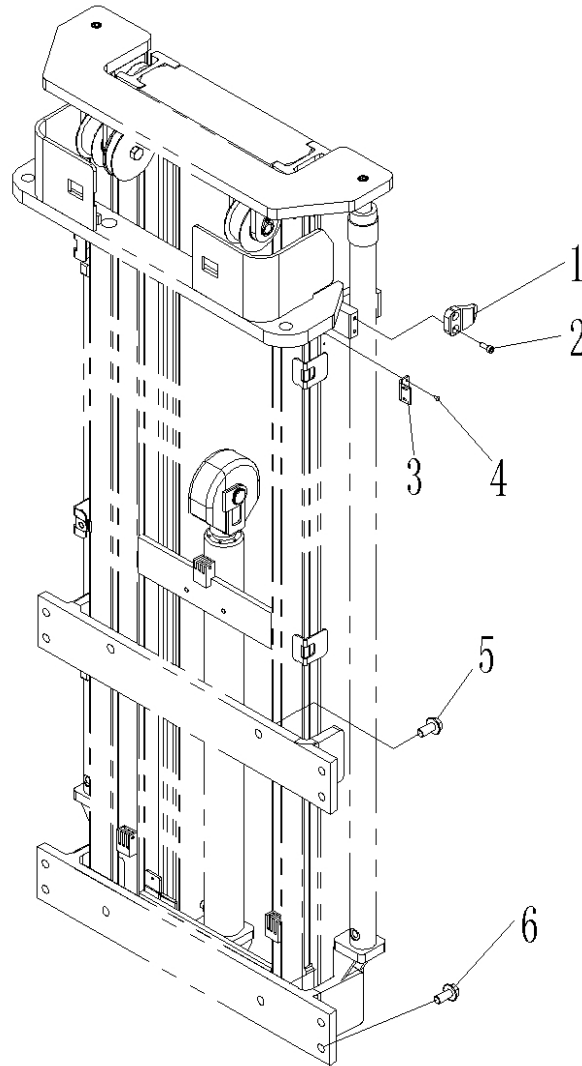

**Fig.20 Mast and other Parts**

No.	Art No.	Description	Qty.	Note
1	3018005004	Cylinder pressing plate	2	
2	0000023044	Screw	4	M8x20
3	9000015321	Limit switch fixing plate	1	
4	1000123003	Screw	2	M4x8
5	0090000658	Bolt	2	M16x35
6	0090000823	Bolt	10	M16x40

Fig.22 Three-stage mast hydraulic system(full free lift)

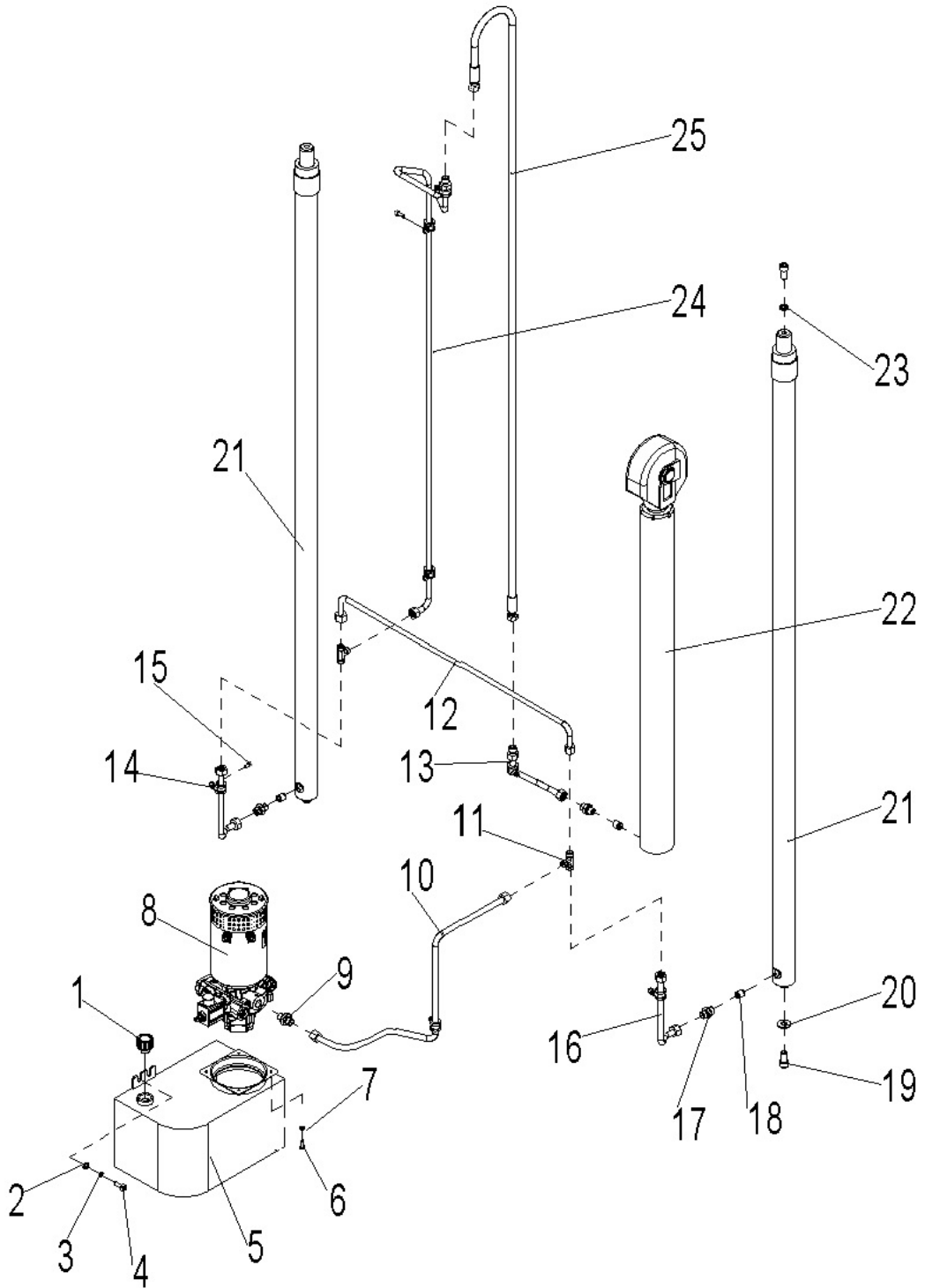
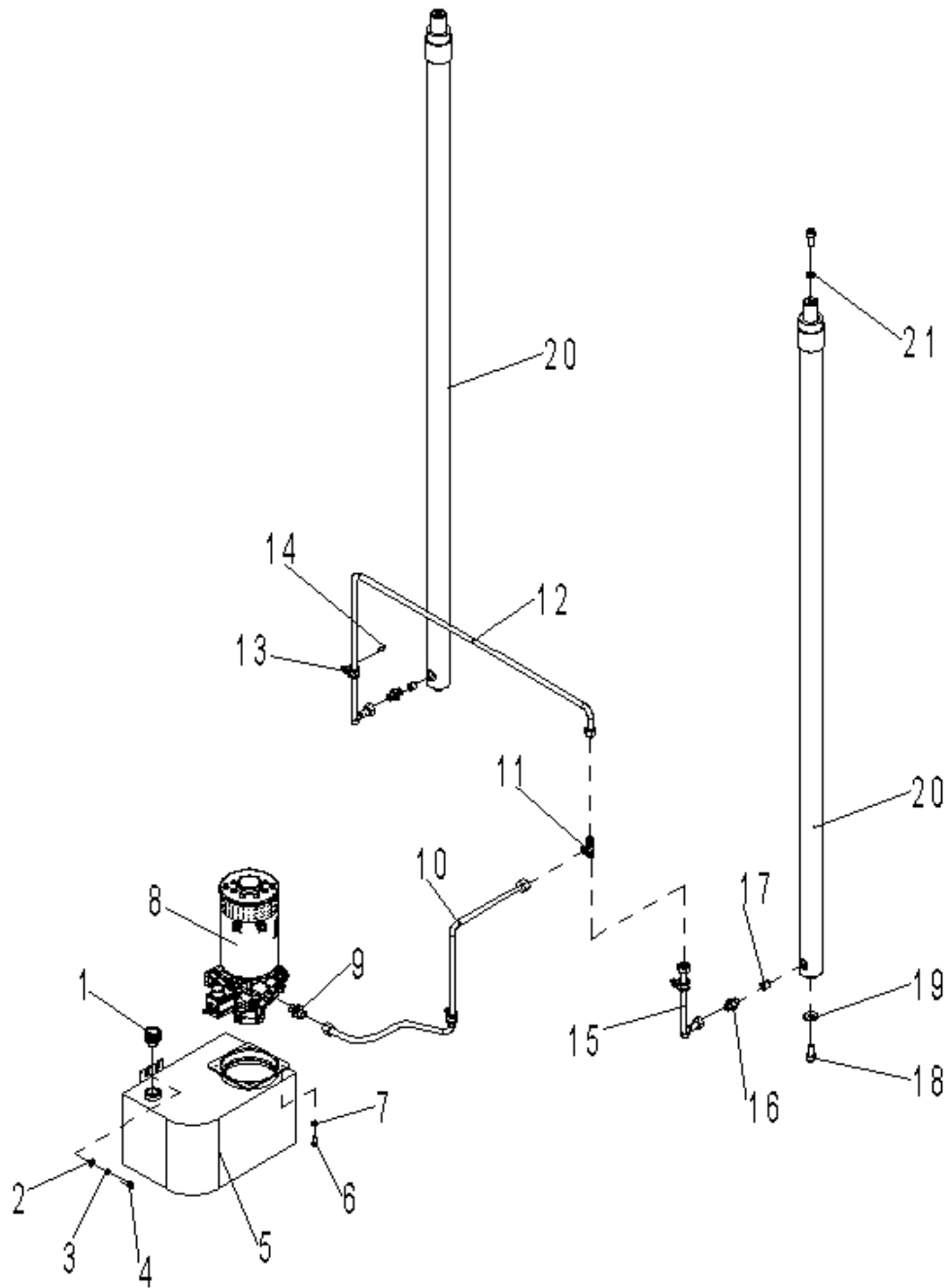

**Fig.21 Three-stage Mast Hydraulic System(full free lift)**

No.	Art No.	Description	Qty.	Note
1	2000303001	Hydraulic oil cylinder cover	1	
2	0000025011	Washer	2	8
3	0000025001	Washer	2	8
4	0000023044	Screw	2	M8x20
5	9000015438	Oil cylinder	1	
6	00900000025	Bolt	4	M6x16
7	0000025011	Washer	4	6
8	9000015649	DC power unit	1	(without oil tank)
9	9000015645	G straight pipe joint	1	
10	9000015646	Special pipe assembly	1	
11	9000007846	Tee coupling	2	
12	9000015375	Connecting steel pipe	1	
13	9000009127	Middle cylinder steel tube A	1	
14	9000008325	YGE pipe clamp	3	
15	0000023604	Screw	3	M6x6
16	9000009113	High pressure steel tube B	2	
17	9000007842	Straight pipe joint	3	
18	2000337001	Safety valve	3	
19	0000023156	Screw	4	M12x25
20	9000015320	Cylinder fixing pad	2	
21	9000015426	Outer cylinder	2	(4600)
	9000015450	Outer cylinder	2	(4300)
	9000015456	Outer cylinder	2	(5300)
	9000015462	Outer cylinder	2	(4000)
22	9000015425	Middle cylinder	1	(4600)
	9000015449	Middle cylinder	1	(4300)
	9000015455	Middle cylinder	1	(5300)
	9000015461	Middle cylinder	1	(4000)
23	0000025024	Washer	2	12
24	9000015330	Middle cylinder steel tube	1	(4600)
	9000015390	Middle cylinder steel tube	1	(4300)
	9000015402	Middle cylinder steel tube	1	(5300)
	9000015414	Middle cylinder steel tube	1	(4000)
25	9000010286	Hydraulic hose assembly	1	4600
	9000010284	Hydraulic hose assembly	1	4300
	9000007817	Hydraulic hose assembly	1	5300
	9000015679	Hydraulic hose assembly	1	4000



Fig.23 Three-stage mast hydraulic system(standard lift)



**Fig.22 Three-stage Mast Hydraulic System(standard lift)**

No.	Art No.	Description	Qty.	Note
1	2000303001	Hydraulic oil cylinder cover	1	
2	0000025011	Washer	2	8
3	0000025001	Washer	2	8
4	0000023044	Screw	2	M8x20
5	9000015438	Oil cylinder	1	
6	00900000025	Bolt	4	M6x16
7	0000025011	Washer	4	6
8	9000015649	DC power unit	1	(without oil tank)
9	9000015645	G straight pipe joint	1	
10	9000015646	Special pipe assembly	1	
11	9000007846	Tee coupling	2	
12	9000015672	Connecting steel pipe	1	
13	9000008325	YGE pipe clamp	3	
14	0000023604	Screw	3	M6x6
15	9000009113	High pressure steel tube B	1	
16	9000007842	Straight pipe joint	2	
17	2000337001	Safety valve	2	
18	0000023156	Screw	4	M12x25
19	9000015320	Cylinder fixing pad	2	
20	9000015285	Outer cylinder	2	4600
	9000015295	Outer cylinder	2	4300
21	0000025024	Washer	2	12

Fig.24 Two-stage mast hydraulic system(full free lift)

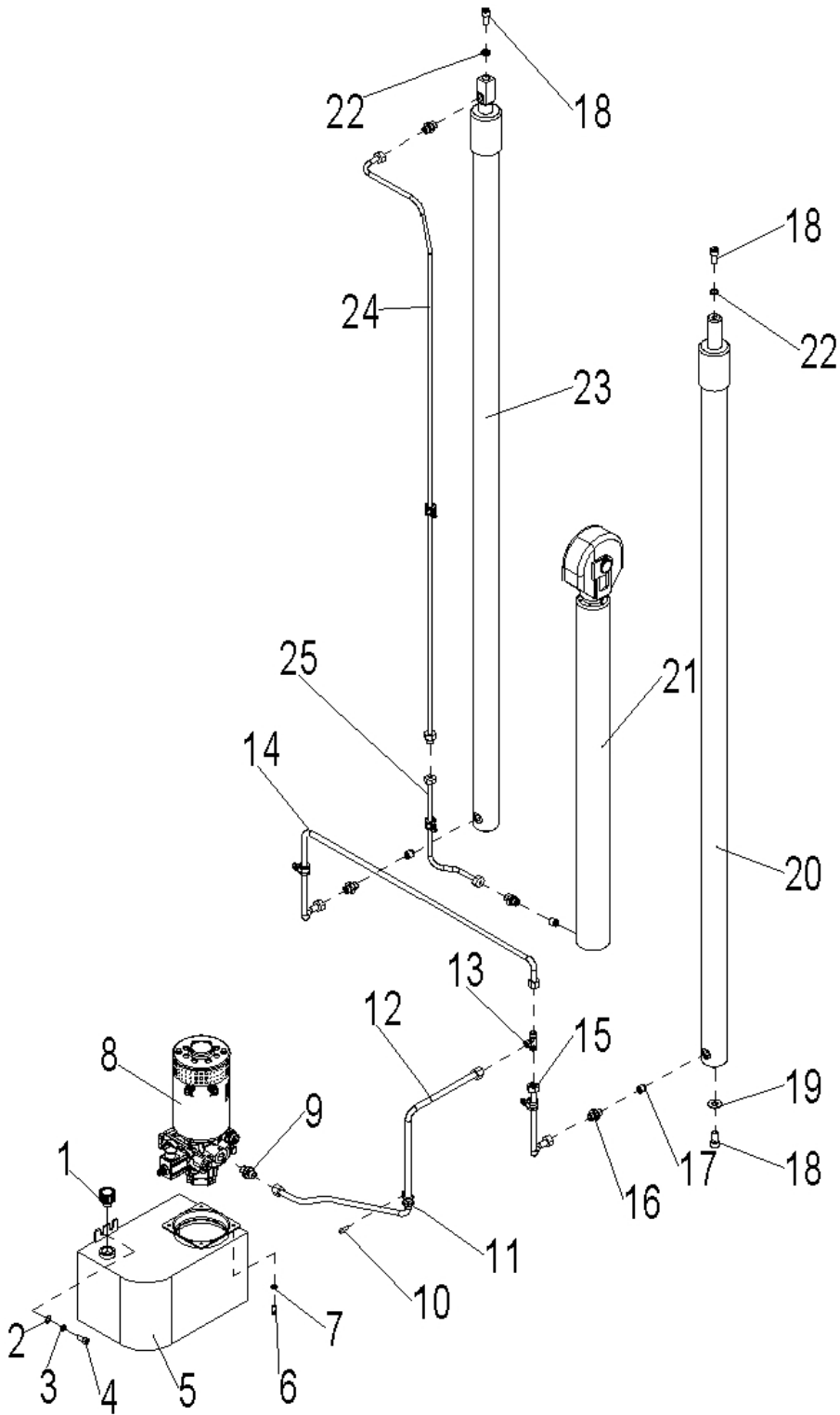

**Fig.23 Two-stage Mast Hydraulic System(full free lift)**

No.	Art No.	Description	Qty.	Note
1	2000303001	Hydraulic cylinder cover	1	
2	0000025011	Washer	2	8
3	0000025001	Washer	2	8
4	0000023044	Screw	2	M8x20
5	9000015438	Oil cylinder	1	
6	00900000025	Bolt	4	M6x16
7	0000025011	Washer	4	6
8	9000015649	DC hydraulic power unit	1	(without tank)
9	9000015645	G straight pipe joint	1	
10	9000008325	YGE pipe clamp	3	
11	0000023604	Screw	3	M6x6
12	9000015646	Special pipe assembly	1	
13	9000007846	Tee coupling	2	
14	9000015193	Connecting steel pipe	1	
15	9000015194	Side steel pipe	1	
16	9000007842	Straight pipe joint	2	
17	2000337001	Safety valve	2	
18	0000023156	Screw	4	M12x25
19	9000015320	Cylinder fixing pad	2	
20	9000015240	Right outer cylinder	1	(3600)
	9000015254	Right outer cylinder	1	(3200)
	9000015265	Right outer cylinder	1	(2900)
21	9000015235	Middle cylinder	1	(3600)
	9000015250	Middle cylinder	1	(3200)
	9000015259	Middle cylinder	1	(2900)
22	0000025024	Washer	2	12
23	9000015237	Left outer cylinder	1	(3600)
	9000015252	Left outer cylinder	1	(3200)
	9000015262	Left outer cylinder	1	(2900)
24	9000015243	Middle cylinder steel pipe 1	1	(3600)
	9000015255	Middle cylinder steel pipe 1	1	(3200)
	9000015267	Middle cylinder steel pipe 1	1	(2900)
25	9000015242	Middle cylinder steel pipe 2	1	

Fig.25 Two-stage mast hydraulic system(standard lift)

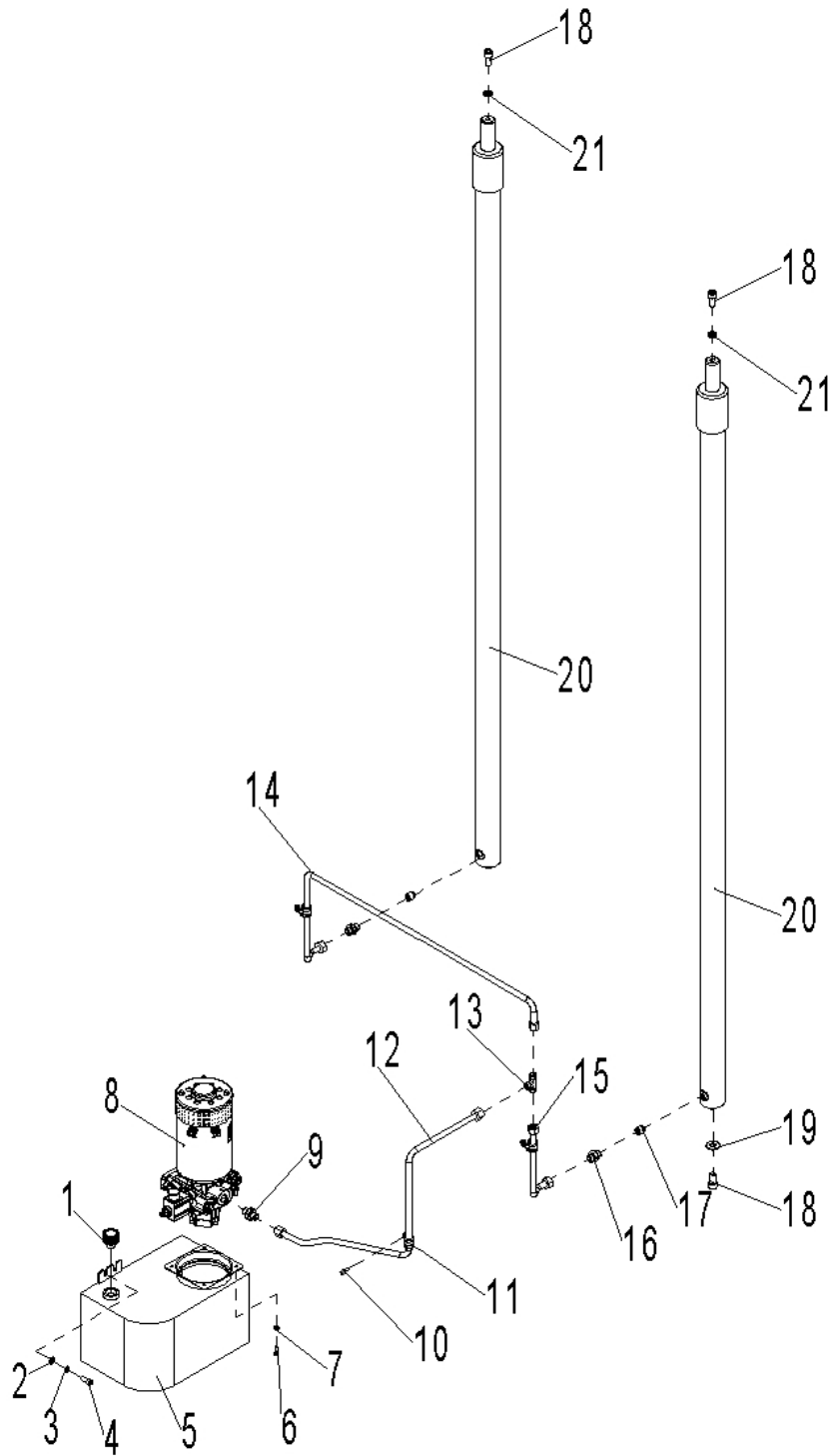

**Fig.24 Two-stage Mast Hydraulic System(standard lift)**

No.	Art No.	Description	Qty.	Note
1	2000303001	Hydraulic oil cylinder cover	1	
2	0000025011	Washer	2	8
3	0000025001	Washer	2	8
4	0000023044	Screw	2	M8x20
5	9000015438	Oil cylinder	1	
6	00900000025	Bolt	4	M6x16
7	0000025011	Washer	4	6
8	9000015649	DC power unit	1	(without oil tank)
9	9000015645	G straight pipe joint	1	
10	9000008325	YGE pipe clamp	3	
11	0000023604	Screw	3	M6x6
12	9000015646	Special pipe assembly	1	
13	9000007846	Tee coupling	2	
14	9000015193	Connecting steel pipe	1	
15	9000015194	Side steel pipe	1	
16	9000007842	Straight pipe joint	2	
17	2000337001	Safety valve	2	
18	0000023156	Screw	4	M12x25
19	9000015320	Cylinder fixing pad	2	
20	9000015202	Outer cylinder	2	(3600)
	9000015211	Outer cylinder	2	(3200)
	9000015216	Outer cylinder	2	(2900)
21	0000025024	Washer	2	12

Fig.26 Three-stage mast outer cylinder assembly(full free lift)

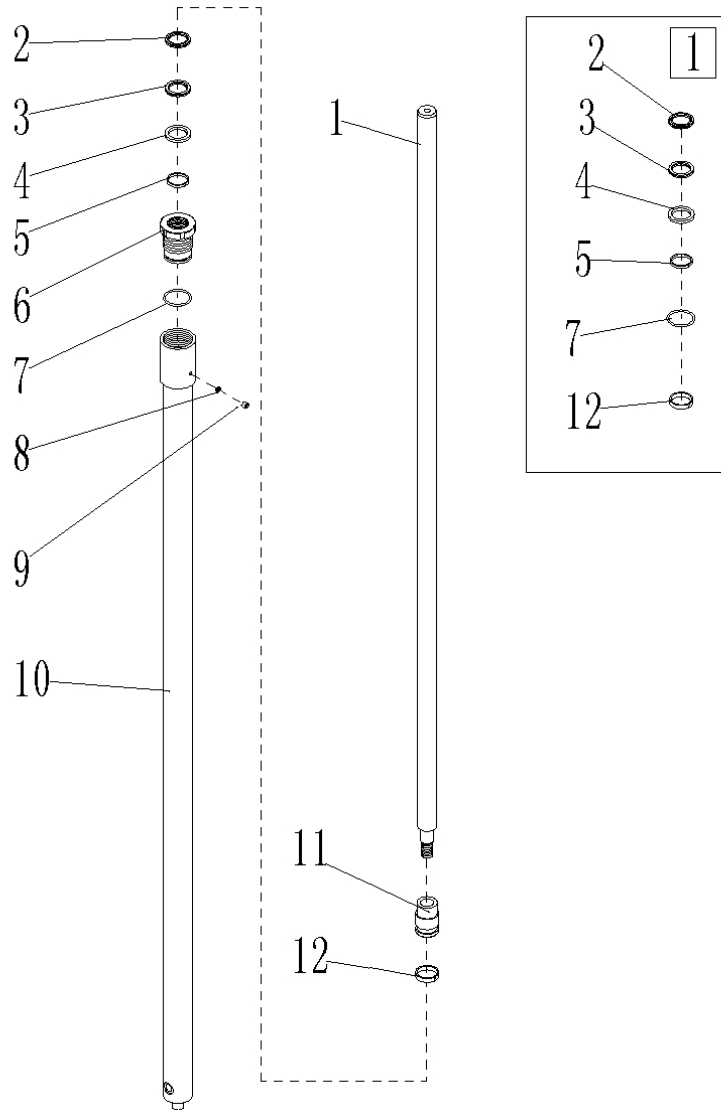
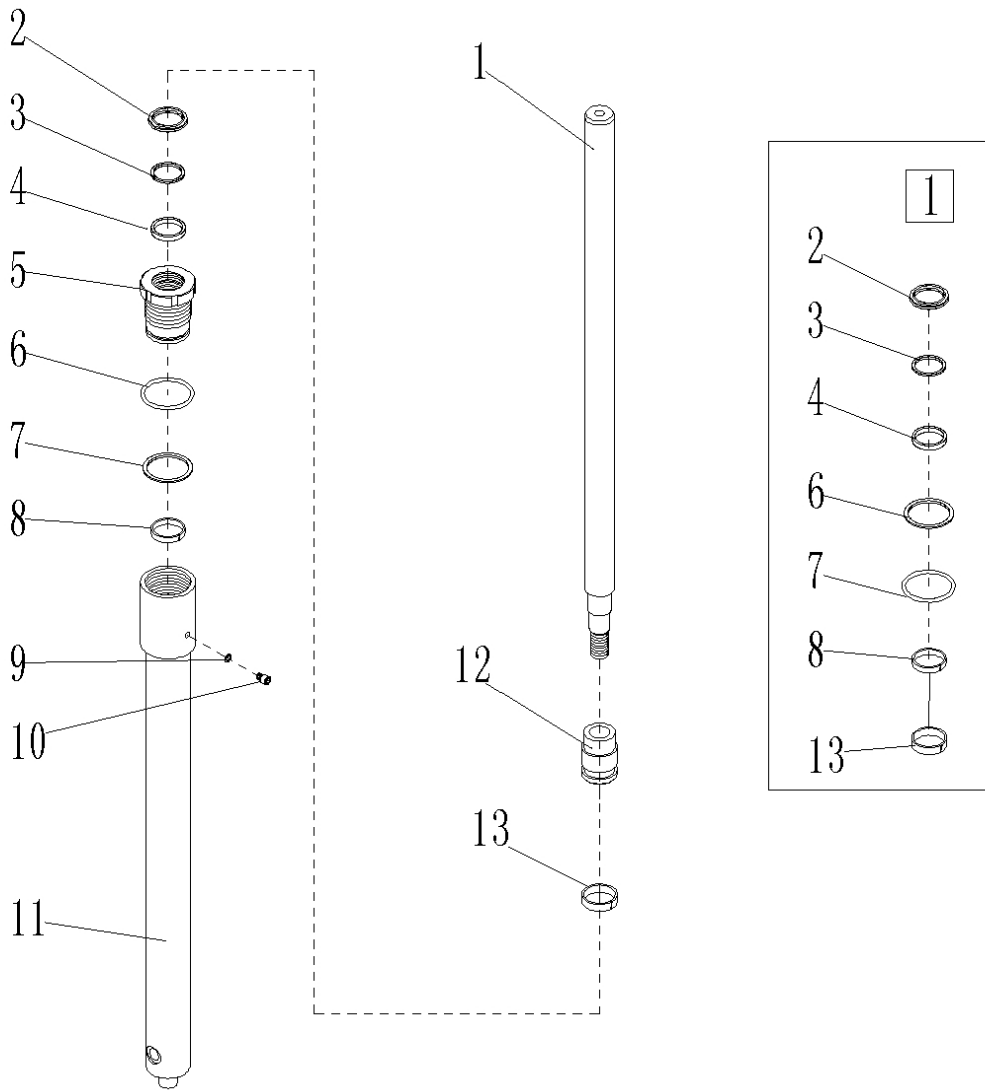

**Fig.25 Three-stage Mast outer Cylinder Assembly(full free lift)**

No.	Art No.	Description	Qty.	Note
1	9000015326	Piston rod	1	4600
	9000015388	Piston rod	1	4300
	9000015400	Piston rod	1	5300
	9000015412	Piston rod	1	4000
2	9000015656	Dust ring	1	38x46x5/6.5
3	9000015657	Seal ring for axle	1	38x48x6
4	9000015658	Seal ring	1	38x48.7x4.2
5	9000015659	Supporting ring for shaft	1	38x42x10
6	9000015327	Cylinder cover	1	
7	9000015660	O ring	1	49.4x3.1
8	0000022026	Combined seal washer	1	8
9	0000023415	Screw	1	M8x10
10	9000015328	Cylinder barrel	1	4600
	9000015389	Cylinder barrel	1	4300
	9000015401	Cylinder barrel	1	5300
	9000015413	Cylinder barrel	1	4000
11	9000015329	Piston	1	
12	9000015661	Supporting ring for hole	1	40x45x10
①	9000015673	Outer cylinder seal assembly	1	



**Fig.27 Three-stage mast middle cylinder assembly(full free lift)**



**Fig.26 Three-stage Mast middle Cylinder Assembly(full free lift)**

No.	Art No.	Description	Qty.	Note
1	9000015323	Piston rod	1	4600
	9000015386	Piston rod	1	4300
	9000015398	Piston rod	1	5300
	9000015410	Piston rod	1	4000
2	9000015662	Dust ring	1	56x64x5/6.5
3	9000015663	Stop collar	1	56x66x2
4	9000010181	Seal ring for axle	1	56x66x10/11
5	9000015322	End cover	1	
6	9000015664	O ring	1	64.4x3.1
7	9000015665	Stop collar	1	65x70x1.25
8	9000015666	Supporting ring for axle	1	56x60x9.7
9	0000022026	Combined sealing washer	1	8
10	0000023415	Screw	1	M8x10
11	9000015324	Cylinder barrel	1	4600
	9000015387	Cylinder barrel	1	4300
	9000015399	Cylinder barrel	1	5300
	9000015411	Cylinder barrel	1	4000
12	9000015325	Piston	1	
13	9000015667	Supporting ring for hole	1	58x63x9.7
⌈	9000015674	Middle cylinder seal assembly	1	

Fig.28 Three-stage mast outer cylinder assembly(standard lift)

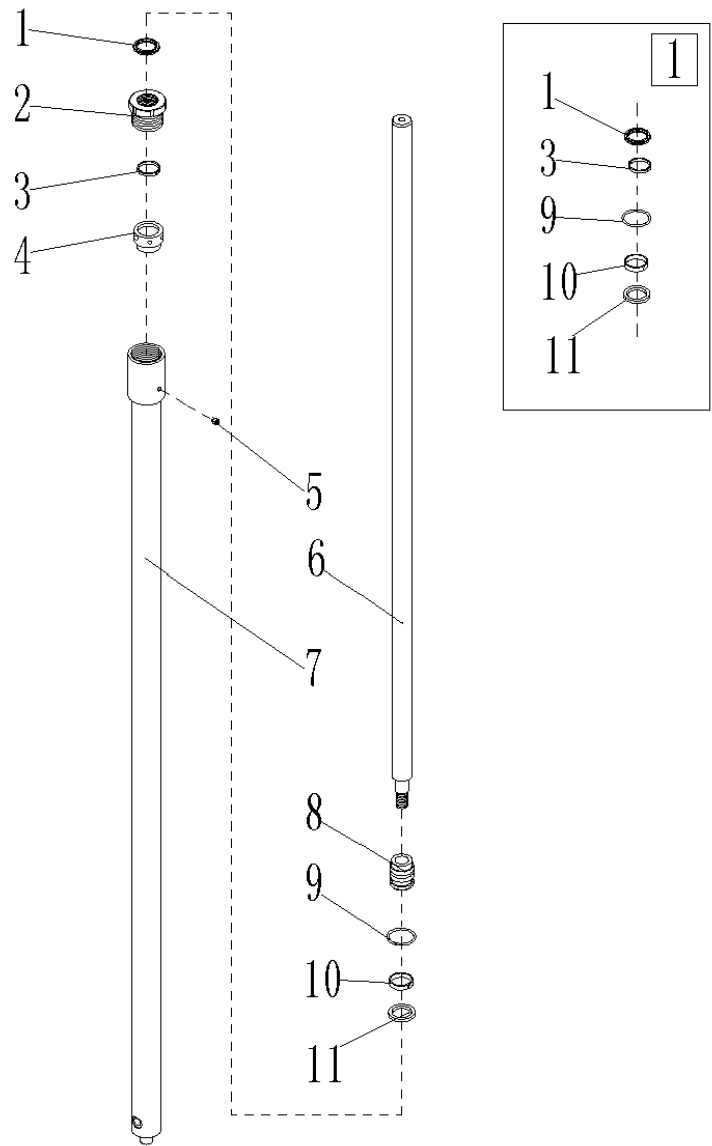

**Fig.27 Three-stage Mast outer Cylinder Assembly(standard lift)**

No.	Art No.	Description	Qty.	Note
1	9000009926	Dust ring	1	40X48X5/6.5
2	9000009183	Blind nut	1	
3	9000015668	Supporting ring for axle	1	40X44X15
4	9000009184	Spacer bush	1	
5	0090000827	Screw		Rc1/8
6	9000015271	Piston rod	1	4600
	9000015274	Piston rod	1	4300
7	9000015286	Cylinder barrel	1	4600
	9000015296	Cylinder barrel	1	4300
8	9000015272	Piston	1	
9	0000022029	O type rubber seal ring	1	50x3.1
10	9000009182	Supporting ring for hole	1	46X50X15
11	9000009178	Seal ring	1	40X50X6/7
□	9000015675	Outer cylinder seal assembly	1	

Fig.29 Two-stage mast outer cylinder assembly(full free lift)

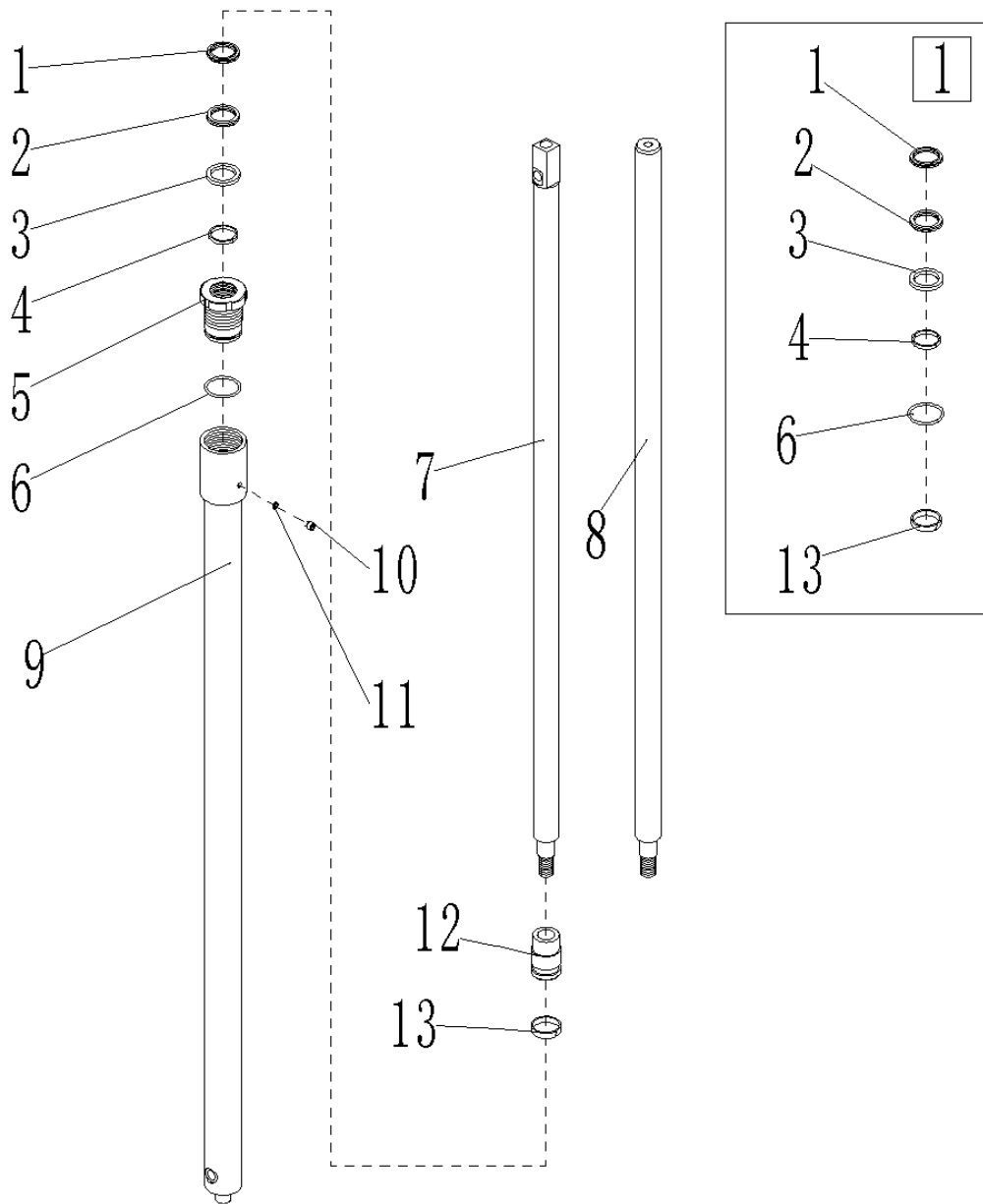

**Fig.28 Two-stage Mast outer Cylinder Assembly(full free lift)**

No.	Art No.	Description	Qty.	Note
1	9000015669	Dust ring	1	28x36x4.5/6
2	9000009708	Seal ring for axle	1	28x35.5x5/5.7
3	9000009710	Seal ring	1	28x38.7x4.2
4	9000009711	Supporting ring for axle	1	28x32x10
5	9000015238	Cylinder cover	1	
6	9000015660	O ring	1	49.4x3.1
7	9000015224	Piston rod	1	3600 left cylinder
	9000015227	Piston rod	1	3200 left cylinder
	9000015263	Piston rod	1	2900 left cylinder
8	9000015241	Piston rod	1	3600 right cylinder
	9000015228	Piston rod	1	3200 right cylinder
	9000015266	Piston rod	1	2900 right cylinder
9	9000015239	Cylinder barrel	1	3600
	9000015253	Cylinder barrel	1	3200
	9000015264	Cylinder barrel	1	2900
10	0000022026	Combined sealing washer	1	8
11	0000023415	Screw	1	M8x10
12	9000015225	Piston	1	
13	9000015661	Supporting ring for hole	1	40x45x10
□	9000015676	Outer cylinder seal assembly	1	

**Fig.30 Two-stage mast middle cylinder assembly(full free lift)**

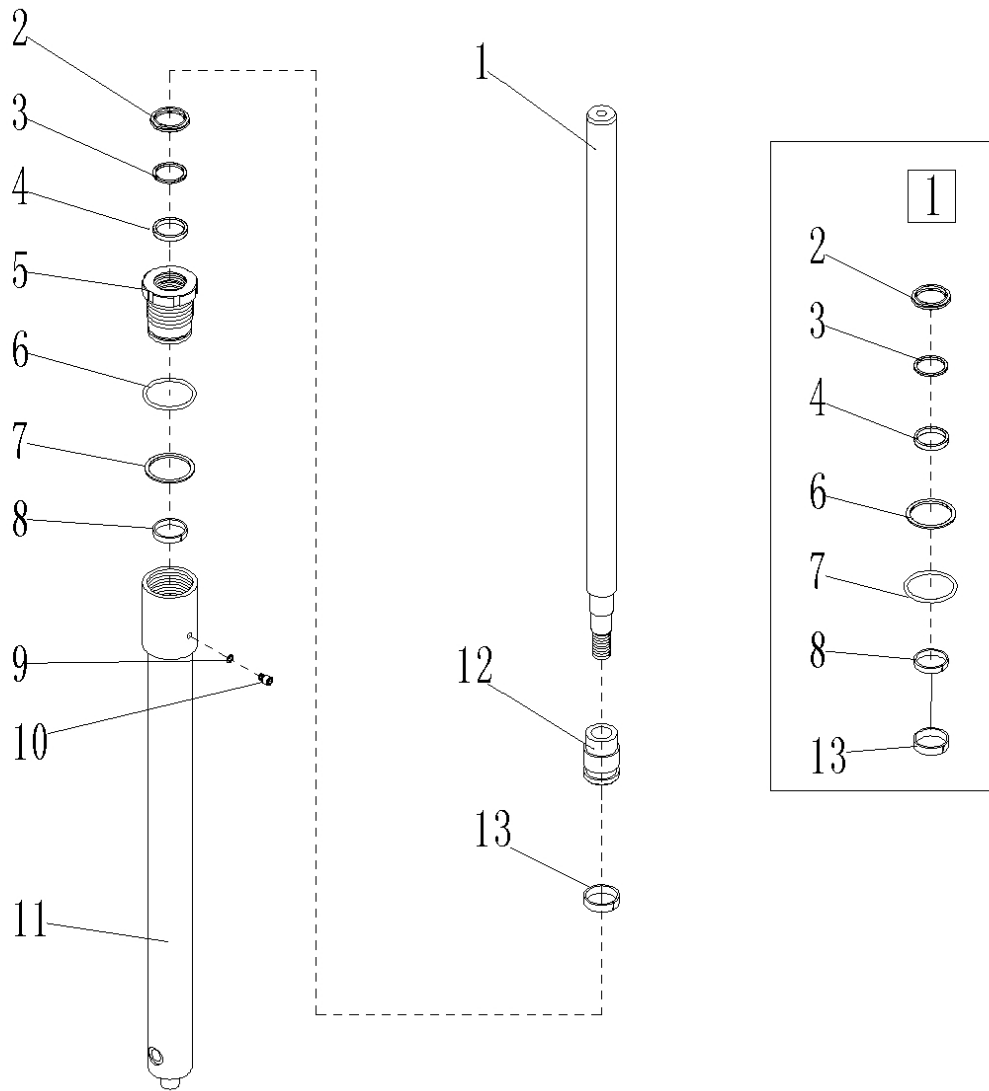
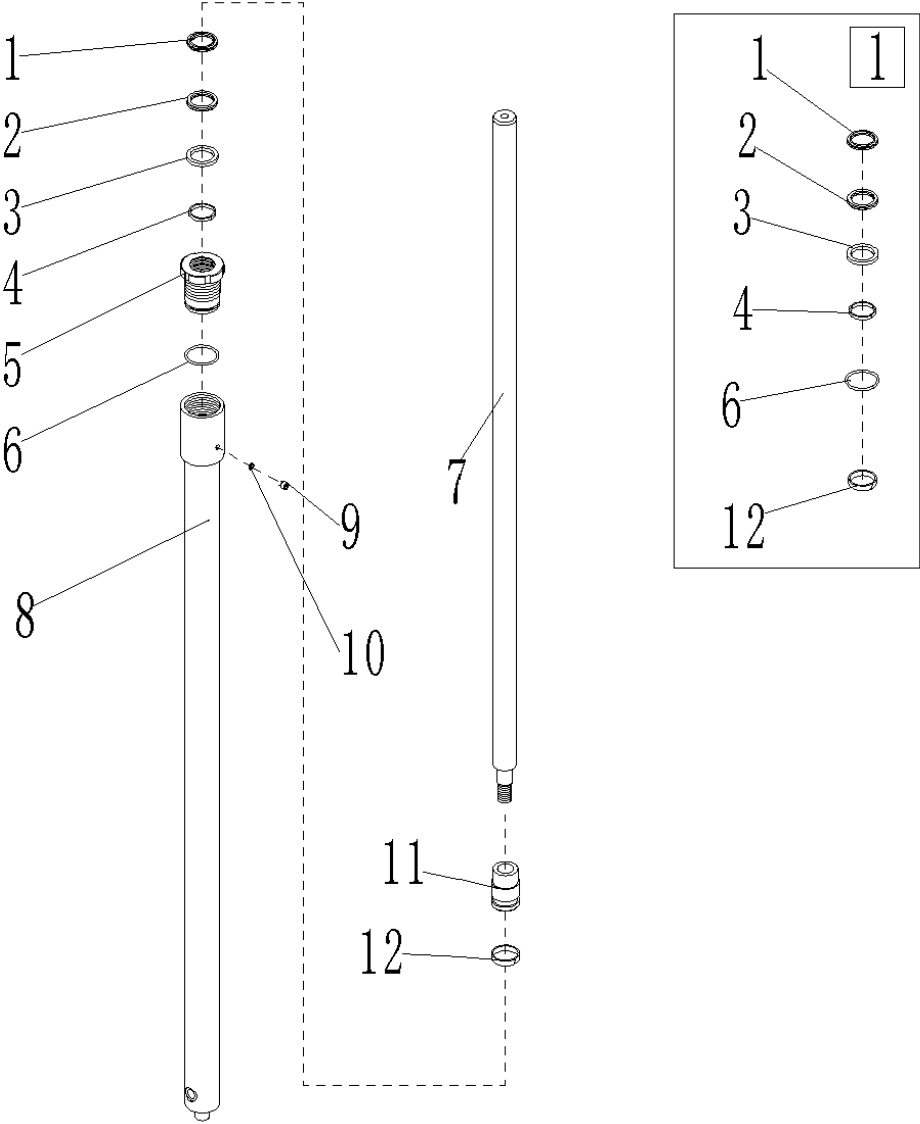

**Fig.29 Two-stage Mast middle Cylinder Assembly(full free lift)**

No.	Art No.	Description	Qty.	Note
1	9000015223	Piston rod	1	3600
	9000015226	Piston rod	1	3200
	9000015260	Piston rod	1	2900
2	9000015662	Dust ring	1	56x64x5/6.5
3	9000015663	Stop collar	1	56x66x2
4	9000010181	Seal ring for axle	1	56x66x10/11
5	9000015322	End cap	1	
6	9000015664	O ring	1	64.4x3.1
7	9000015665	Stop collar	1	65x70x1.25
8	9000015666	Supporting ring for axle	1	56x60x9.7
9	0000022026	Combined sealing washer	1	8
10	0000023415	Screw	1	M8x10
11	9000015236	Cylinder barrel	1	3600
	9000015251	Cylinder barrel	1	3200
	9000015261	Cylinder barrel	1	2900
12	9000015325	Piston	1	
13	9000015667	Supporting ring for hole	1	58x63x9.7
□	9000015677	Middle cylinder seal assembly	1	



Fig.31 Two-stage mast outer cylinder assembly(standard lift)



**Fig.30 Two-stage Mast outer cylinder Assembly(standard lift)**

No.	Art No.	Description	Qty.	Note
1	9000009926	Dust ring	1	40x48x5/6.5
2	9000009170	Seal ring for axle	1	40x50x6/7
3	9000015671	Seal ring	1	40x50.7x4.2
4	9000009927	Supporting ring for axle	1	40x44x10
5	9000015181	Cylinder cover	1	
6	9000015660	O ring	1	49.4x3.1
7	9000015180	Piston rod	1	3600
	9000015178	Piston rod	1	3200
	9000015179	Piston rod	1	2900
8	9000015203	Cylinder barrel	1	3600
	9000015212	Cylinder barrel	1	3200
	9000015217	Cylinder barrel	1	2900
9	0000023415	Screw	1	M8x10
10	0000022026	Combined sealing washer	1	8
11	9000015225	Piston	1	
12	9000015661	Supporting ring for hole		40x45x10
□	9000015678	Outer cylinder seal assembly	1	

**Fig.32 Drive system assembly**

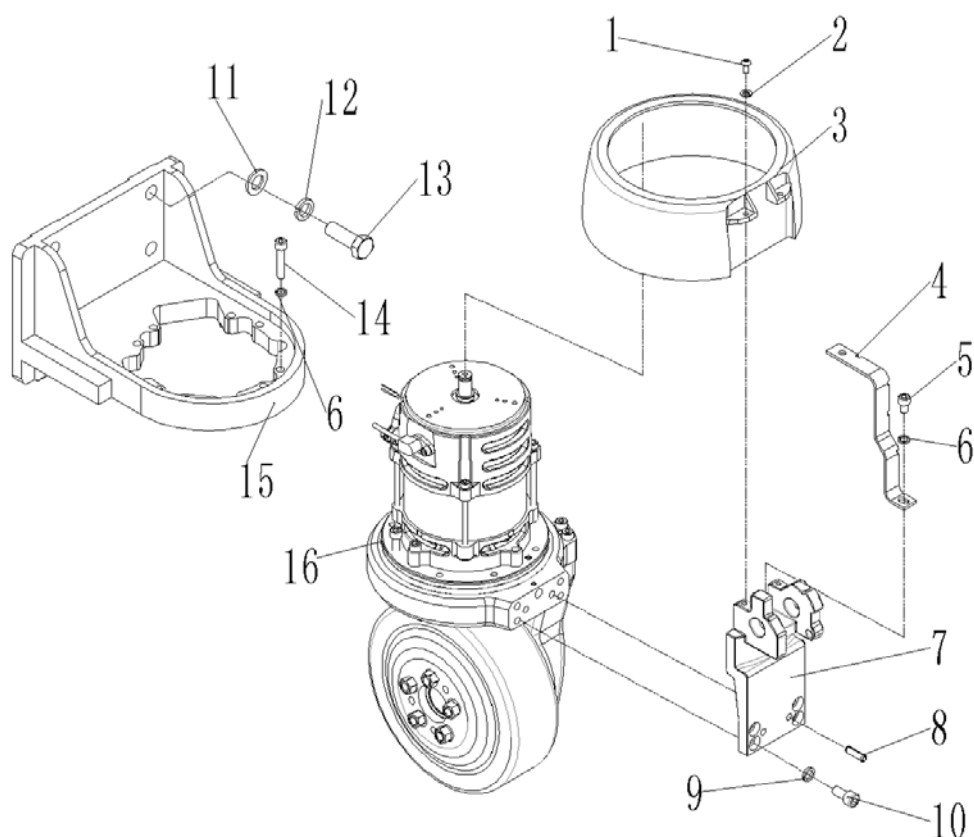

**Fig.31 Drive System Assembly**

No.	Art No.	Description	Qty.	Note
1	0000023045	Screw	2	M6x12
2	0000023055	Washer	2	6
3	9000015376	Driving wheel cover	1	
4	9000015378	Cable holder	1	
5	0000023089	Screw	1	M8x12
6	0000025001	Washer	5	8
7	9000011355	Handle seat	1	
8	0000028116	Elastic dowel pin	2	8x26
9	0000023006	Washer	4	10
10	0000023034	Screw	4	M10x20
11	0000025029	Washer	4	16
12	0000025055	Washer	4	16
13	0000023583	Bolt	4	M16x45
14	0000023077	Screw	4	M8x40
15	9000015377	Driving wheel seat	1	
16	9000010249	AC vertical drive assembly	1	

Fig.33 Load wheel assembly

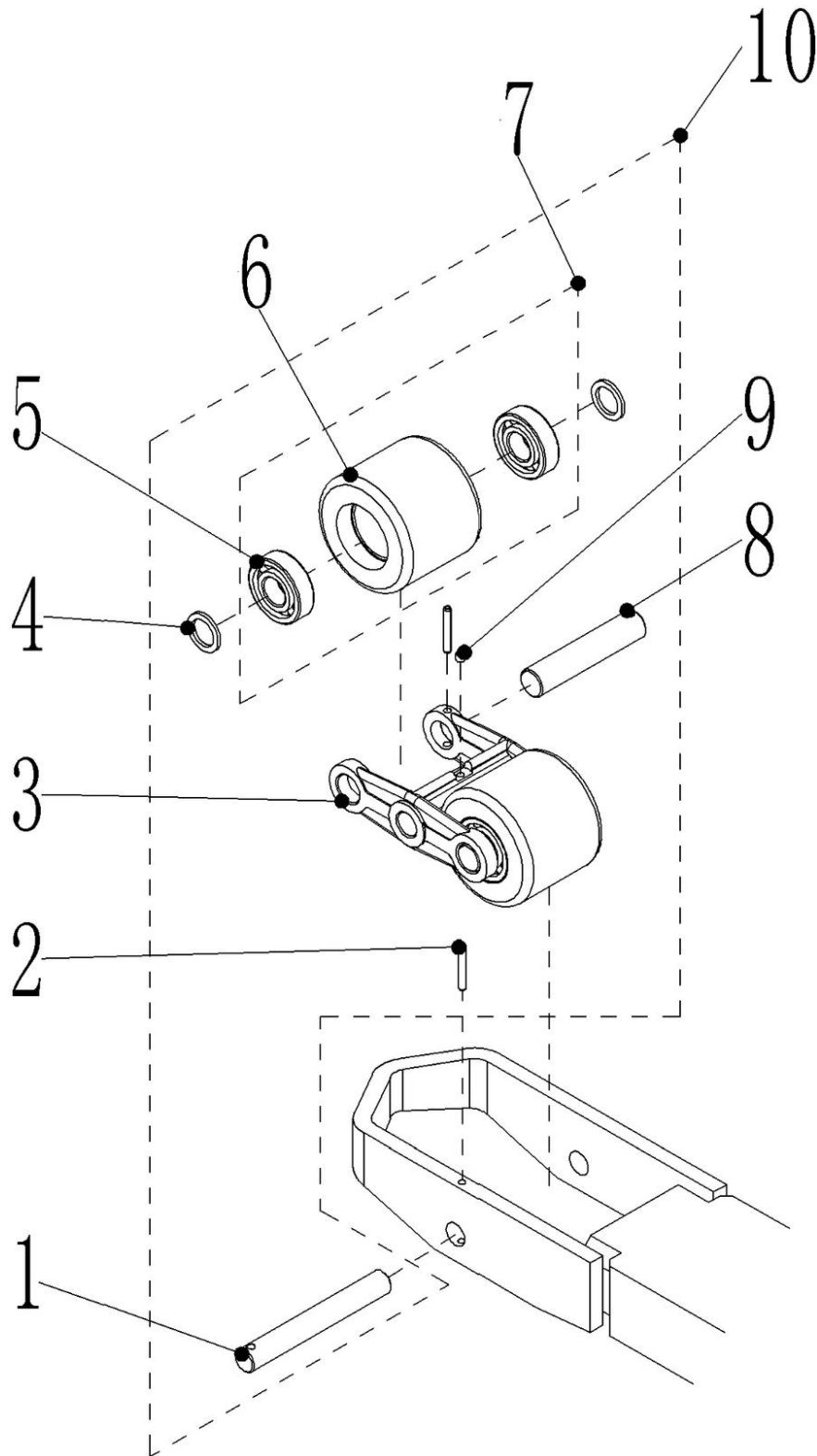

**Fig.32 Load Wheel Assembly**

No.	Art No.	Description	Qty.	Note
1	9000012092	Connecting shaft	2	
2	0000028009	Elastic dowel pin	6	5x35
3	9000012093	Double wheel carrier	2	
4	9000010718	Adjusting washer	8	(thickness 2.5)
5	0000027001	Bearing	8	6204
6	1000507011	Load wheel	4	Ø84X70
7	9000010727	Wheels fittings	4	
8	9000012094	Small wheel shaft	4	
9	0000030001	Grease cup	1	6
10	9000010728	Load wheel assembly	2	

**Fig.34 Handle assembly**

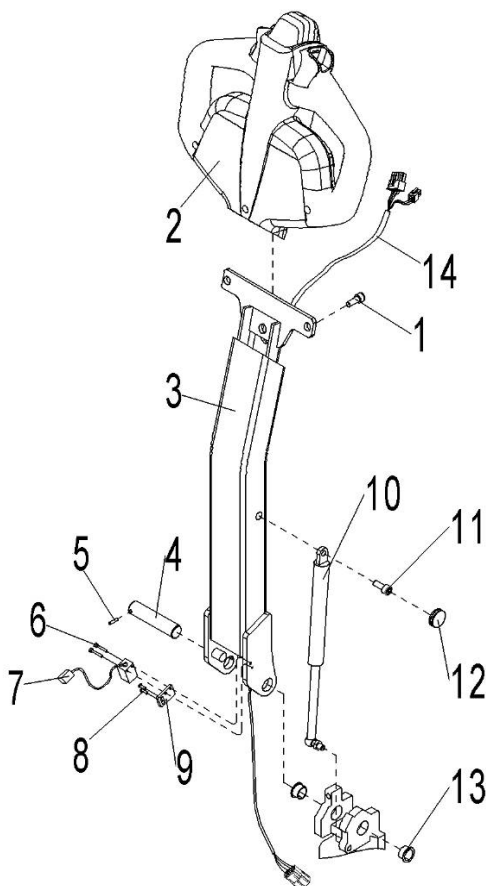

**Fig.33 Handle Assembly**

No.	Art No.	Description	Qty.	Note
1	0000023047	Screw	2	M8x25
2	1100100001	Canbus control handle C	1	94300-90
3	9000010693	Hander bar	1	
4	9000010694	Spindle	1	
5	0000028024	Elastic dowel pin	1	4x16
6	0000023075	Screw	2	M3x20
7	9000008329	9 Interlock switch	1	
8	0000023056	Screw	2	M4x12
9	9000010695	Switch baseplate	1	
10	9000011289	Air spring	1	
11	0000023044	Screw	1	M8x20
12	9000010696	Envelope	1	
13	0000013002	bushing	2	20x22x12
14	9000010635	Handle control harness	1	

**Fig.35 Pump system**

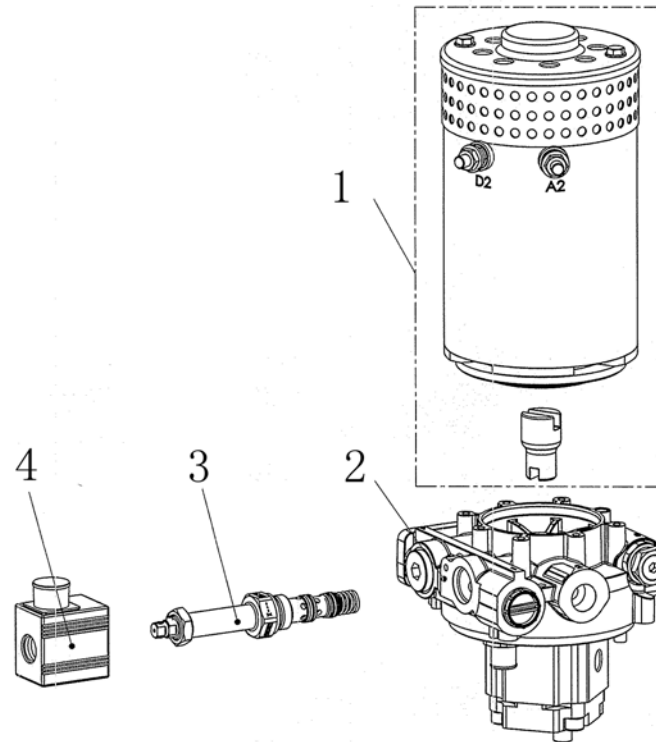

**Fig.34 Pump System**

No.	Art No.	Description	Qty.	Note
1	9000015637	Motor	1	3.2KW
2	9000015638	Centre valve	1	
3	9000015639	Solenoid valve core	1	
4	9000015640	Coil	1	

**Fig.36 Main circuit harness**

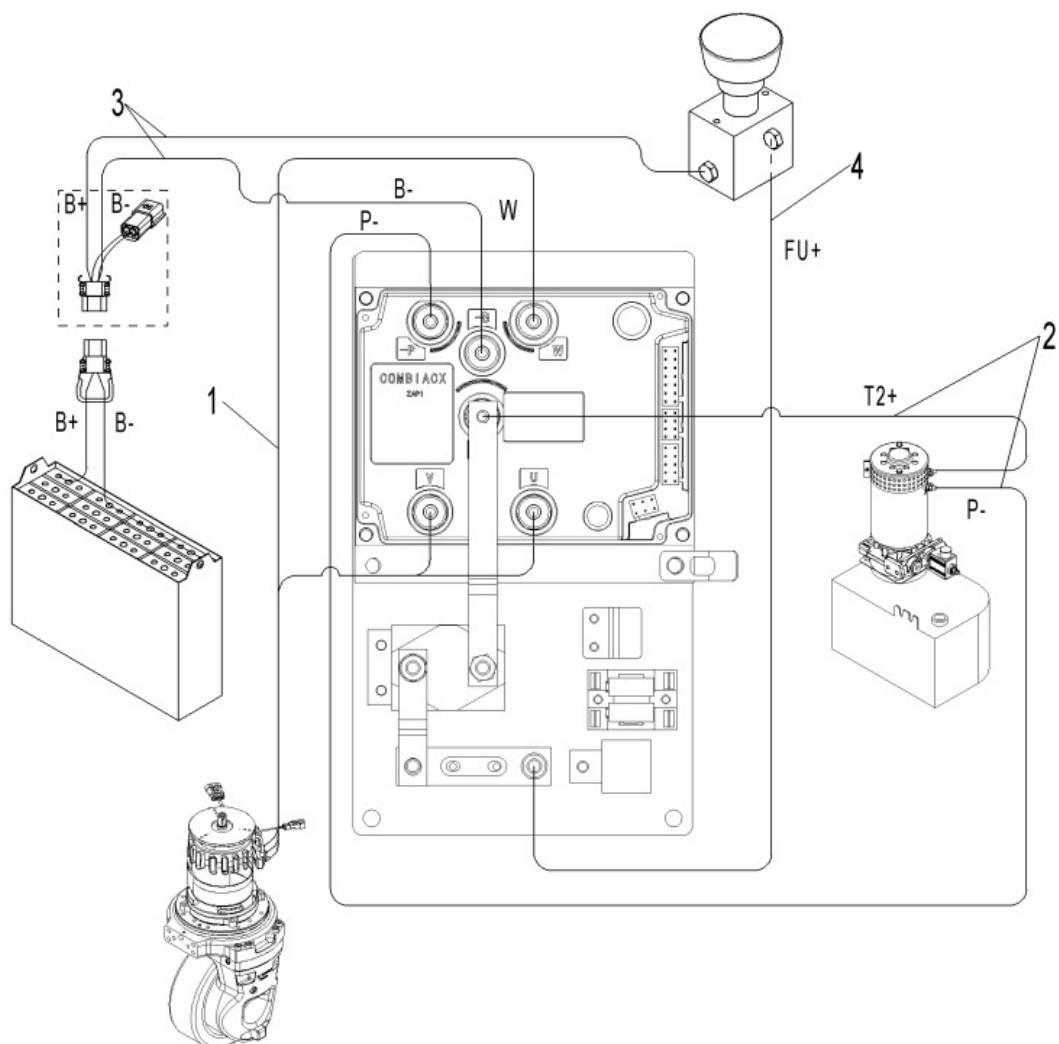
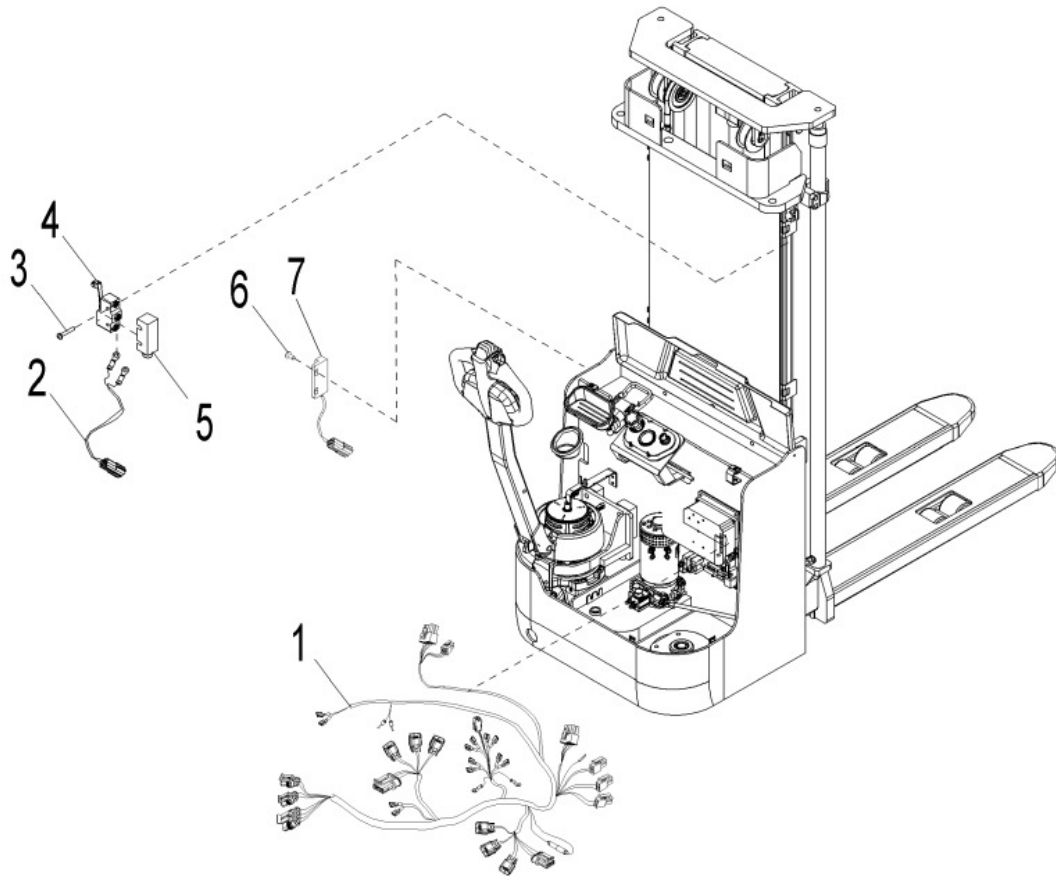

**Fig.35 Main circuit harness**

No.	Art No.	Description	Qty.	Note
1	9000010652	Drive motor harness	1	
2	9000010653	Pump motor harness	1	
3	9000010654	Power harness	1	
4	9000010655	Harness	1	FU+



**Fig.37 Electrical general part**



**Fig.36 Electrical general Part**

No.	Art No.	Description	Qty.	Note
1	9000010649	Main control harness	1	
2	9000008360	Limit control harness	1	
3	0000023033	Screw	2	M4×25
4	2040634001	Micro switch	1	XZ-15GW22-B
5	2040603002	Micro switch protective cover	1	
6	0000023216	Screw	3	M3×8
7	9000008332	Magnet switch	1	HWK23

**Fig.38 Controller assembly**

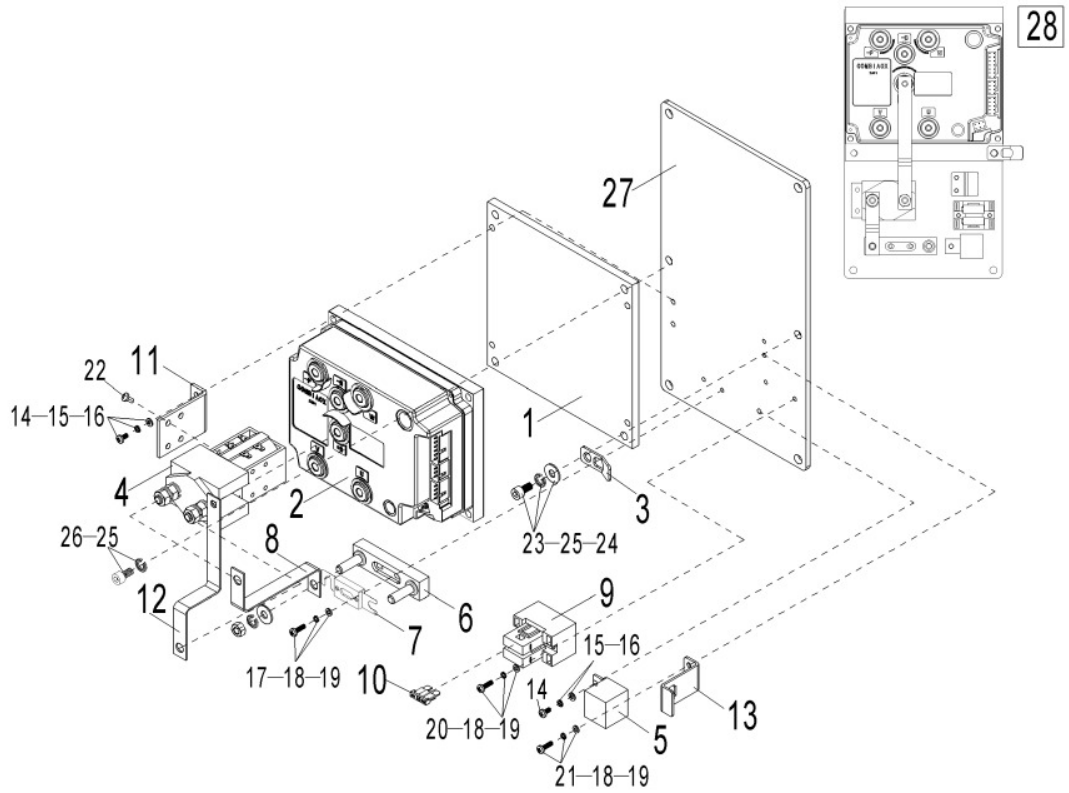

**Fig.37 Controller Assembly**

No.	Art No.	Description	Qty.	Note
1	9000010659	Aluminium plate	1	
2	9000016047	Controller	1	COMBIACX24V/240A+270A
3	9000009791	Line hanging board	3	
4	2390434003	Contactor	1	SW180B-4 DC24V
5	1000434041	Relay	1	ACR01F-F-1AD DC24V
6	1000434007	Fuse seat	1	SY Y
7	9000008635	Fuse	1	350A
8	9000010657	Copper bar	1	
9	9000008586	Fuse seat	1	BD-2X10A-1
10	1000434040	Plug fuse	2	10A
11	9000000002	Contactor holder	1	
12	9000010656	Copper bar	1	
13	9000007679	Programmer plug-in holder	1	
14	0000023516	Screw	3	M5x10
15	0000025015	Washer	3	5
16	0000025014	Washer	3	5
17	0000023211	Screw	6	M4x16
18	0000025018	Washer	6	4
19	0000025019	Washer	6	4
20	0000023019	Screw	2	M4x30
21	0000023307	Screw	6	M4x10
22	0090000395	Screw	2	M5x8
23	0000023166	Screw	1	M8x20
24	0000025005	Washer	1	8
25	0000025001	Washer	2	8
26	0000023089	Screw	2	M8x16
27	9000015362	Controller fixing plate	1	
28	9000010658	Controller assembly	1	

**Fig.39 Load backrest**

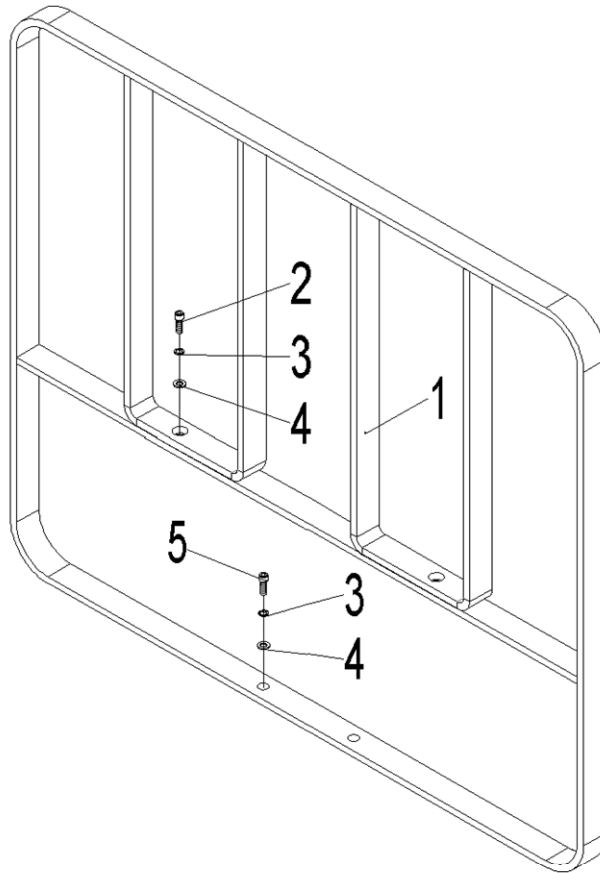

**Fig.38 Load Backrest**

No.	Art No.	Description	Qty.	Note
1	9000008259	Load backrest	1	
2	0000023088	Screw	2	M10×25
3	0000025002	Washer	4	10
4	0000023006	Washer	4	10
5	0000023029	Screw	2	M10×35

**Fig.40 Load backrest (straddle)**

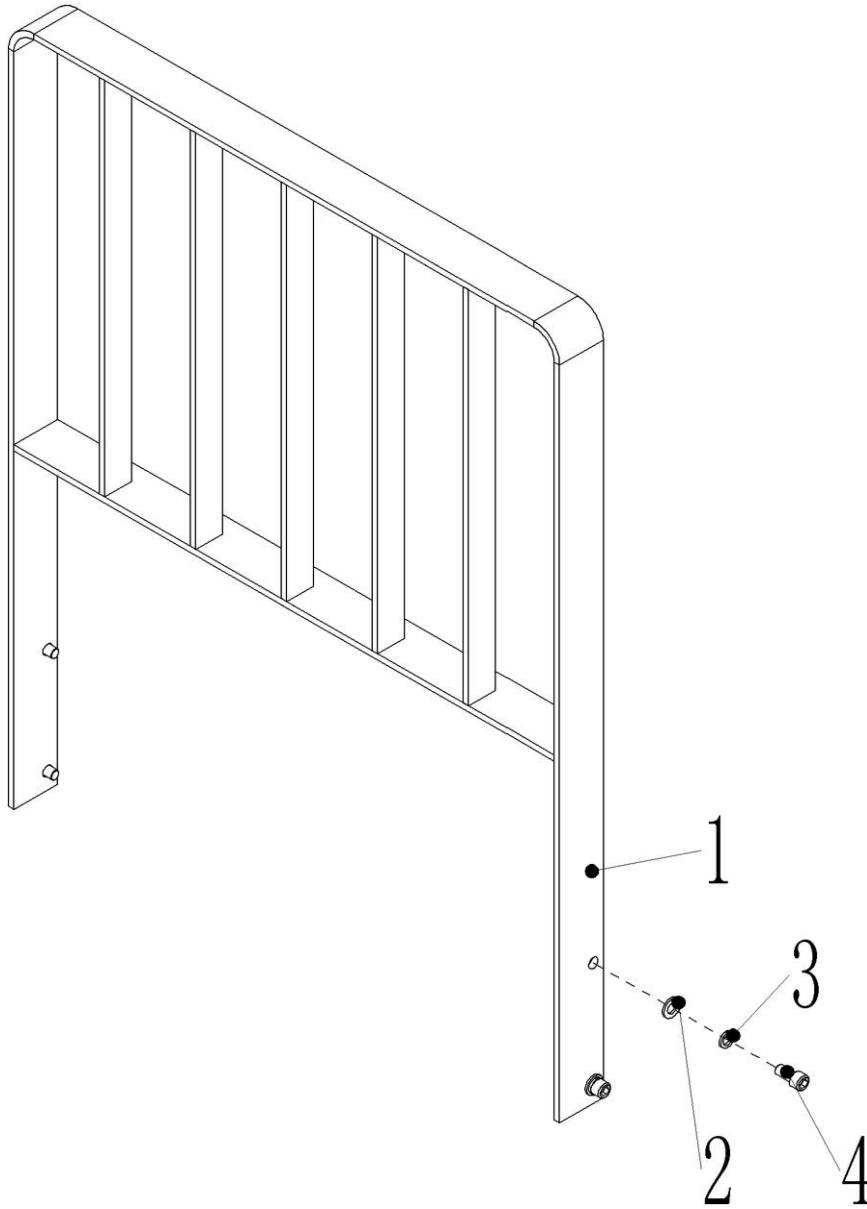

**Fig.39 Load backrest (straddle)**

No.	Art No.	Description	Qty.	Note
1	9000016305	Load backrest	1	
2	0000025024	Spring washer	4	12
3	0000025032	Washer	4	12
4	0000023156	Screw	4	M12x25

### Easy worn parts list

No.	Art No.	Description	Qty.	Fig./Position	Note
1	0000027013	Bearing	2	Fig.12/3	Steering wheel
2	0000027001	Bearing	2	Fig.12/11 Fig.33/5	Steering wheel Load roller assembly
3	2210416001	Rear wheel	1	Fig.12/12	Steering wheel assembly
4	9000015656	Dust ring	1	Fig.26/2	Three-stage Mast outer Cylinder Assembly(full free lift)
5	9000015657	Seal ring	1	Fig.26/3	
6	9000015658	Seal ring	1	Fig.26/4	
7	9000015660	O ring	3	Fig.26/7 Fig.29/6 Fig.31/6	Three-stage Mast outer Cylinder Assembly(full free lift) Two-stage Mast outer Cylinder Assembly(full free lift) Two-stage Mast outer cylinder Assembly(standard lift)
8	9000015661	Supporting ring	3	Fig.26/12 Fig.29/13 Fig.31/12	Three-stage Mast outer Cylinder Assembly(full free lift) Two-stage Mast outer Cylinder Assembly(full free lift) Two-stage Mast outer cylinder Assembly(standard lift)
9	9000015673	Outer cylinder seal assembly	1	Fig.26/11	Three-stage Mast outer Cylinder Assembly(full free lift)
10	9000015662	Dust ring	1	Fig.27/2 Fig.30/2	Three-stage Mast middle Cylinder Assembly(full free lift) Two-stage Mast middle Cylinder Assembly(full free lift)
11	9000015663	Circlip	1	Fig.27/3 Fig.30/3	Three-stage Mast middle Cylinder Assembly(full free lift) Two-stage Mast middle Cylinder Assembly(full free lift)
12	9000010181	Seal ring	2	Fig.27/4 Fig.30/4	Three-stage Mast middle Cylinder Assembly(full free lift) Two-stage Mast middle Cylinder Assembly(full free lift)
13	9000015664	O ring	1	Fig.27/6 Fig.30/6	Three-stage Mast middle Cylinder Assembly(full free lift) Two-stage Mast middle Cylinder Assembly(full free lift)
14	9000015665	Circlip	1	Fig.27/7	Three-stage Mast middle

				Fig.30/7	Cylinder Assembly(full free lift) Two-stage Mast middle Cylinder Assembly(full free lift)
15	9000015666	Supporting ring	1	Fig.27/8 Fig.30/8	Three-stage Mast middle Cylinder Assembly(full free lift) Two-stage Mast middle Cylinder Assembly(full free lift)
16	9000015667	Supporting ring	1	Fig.27/13 Fig.30/8	Three-stage Mast middle Cylinder Assembly(full free lift) Two-stage Mast middle Cylinder Assembly(full free lift)
17	9000015674	Middle cylinder seal assembly	1	Fig.27/11	Three-stage Mast middle Cylinder Assembly(full free lift)
18	9000009926	Dust ring	2	Fig.28/1 Fig.31/1	Three-stage Mast outer Cylinder Assembly(standard lift) Two-stage Mast outer cylinder Assembly(standard lift)
19	9000015668	Supporting ring	1	Fig.28/3	Three-stage Mast outer Cylinder Assembly(standard lift)
20	0000022029	O ring	1	Fig.28/9	
21	9000009182	Supporting ring	1	Fig.28/10	
22	9000009178	Seal ring	1	Fig.28/11	
23	9000015675	Outer cylinder seal assembly	1	Fig.28/11	
24	9000015669	Dust ring	1	Fig.29/1	Two-stage Mast outer Cylinder Assembly(full free lift)
25	9000009708	Seal ring	1	Fig.29/2	
26	9000009710	Seal ring	1	Fig.29/3	
27	9000009711	Supporting ring	1	Fig.29/4	
28	9000015660	O ring	1	Fig.29/6	
29	9000015676	Outer cylinder seal assembly	1	Fig.29/11	
30	9000015677	Middle cylinder seal assembly	1	Fig.30/11	Two-stage Mast middle Cylinder Assembly(full free lift)
31	9000009170	Seal ring	1	Fig.31/2	Two-stage Mast outer cylinder Assembly(standard lift)
32	9000015671	Seal ring	1	Fig.31/3	
33	9000009927	Supporting ring	1	Fig.31/4	
34	9000015678	Outer cylinder seal assembly	1	Fig.31/11	
35	1000507011	Load roller	4	Fig.33/6	Load roller assembly
36	9000010728	Load roller assembly	2	Fig.33/10	
37	9000008329	Inter lock switch	1	Fig.34/7	Handle assembly
38	9000011289	Air spring	1	Fig.34/10	

39	2040634001	Micro switch	1	Fig.37/4	Electrical general Part
40	9000008332	Magnet switch	2	Fig.37/7	
41	9000008635	Fuse	1	Fig.38/7	Controller assembly
42	1000434040	Fuse	1	Fig.38/10	