

# SPAREPARTS LIST

## Electric Stacker PS26TSL

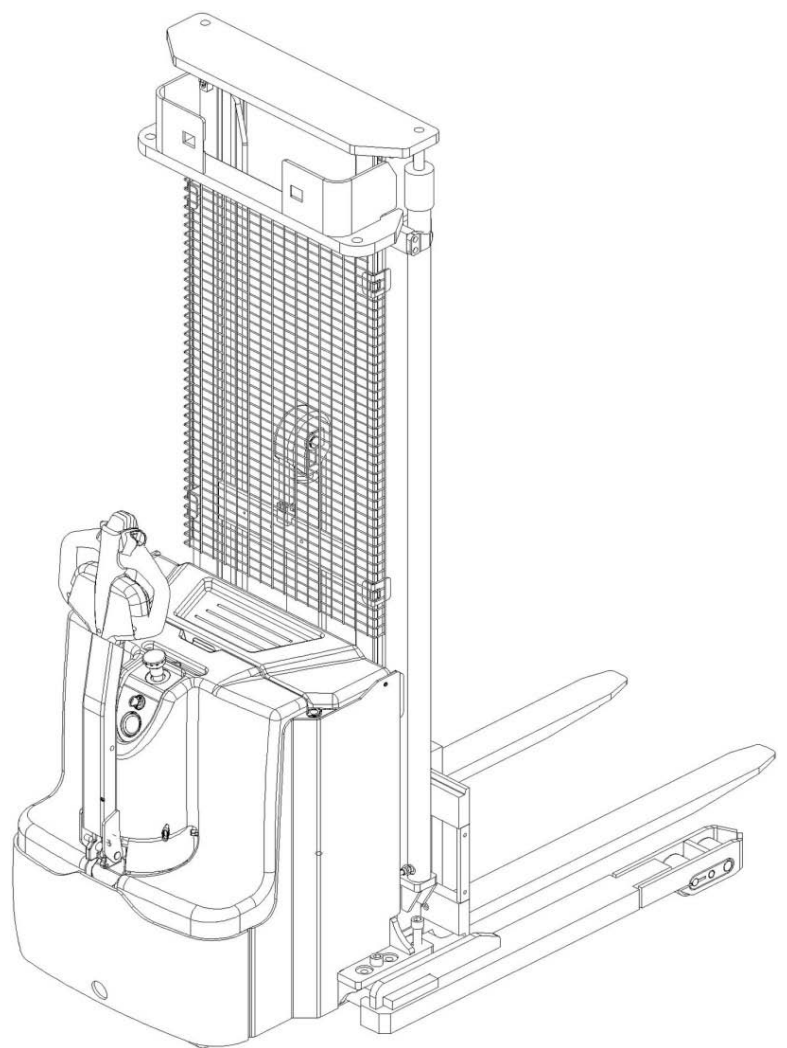

Version 04/2019

From truck identification number:

PS26TSL-BPT-002-EN

# Catalogue

Fig.1 Label (For EU) .....	1
Fig.2 Label (For US) .....	2
Fig. 3 Fork carriage .....	3
Fig. 4 Chassis assembly .....	4
Fig. 5 Power supply (built-in charger) .....	6
Fig. 6 Instrument components.....	8
Fig. 7 Battery cover assembly .....	9
Fig. 8 Support wheel components .....	10
Fig. 9 Two-stage mast system (full free lift).....	12
Fig. 10 Two-stage mast system (standard lift).....	13
Fig. 11 Two-stage mast chain system (full free lift).....	14
Fig. 12 Two-stage mast chain system (standard lift) .....	16
Fig. 13 Mast and other parts.....	18
Fig. 14 Two-stage mast hydraulic system (full free lift) .....	20
Fig. 15 Two-stage mast hydraulic system (standard lift).....	22
Fig. 16 Two-stage mast outer cylinder assembly (full free lift) .....	24
Fig. 17 Two-stage mast middle cylinder assembly (full free lift) .....	26
Fig. 18 Two-stage mast outer cylinder assembly (standard lift).....	28
Fig. 19 Drive system assembly .....	30
Fig. 20 Driving assembly .....	32
Fig. 21 Load wheel assembly .....	34
Fig. 22 Tiller assembly .....	35
Fig. 23 Pump system .....	36
Fig. 24 Main circuit wiring harness .....	37
Fig.25 Electrical parts .....	38
Fig. 26 Controller components (COMBIACX) .....	40
Fig. 27 Load backrest .....	42
Easy worn part list.....	43

**Fig.1 Label (For EU)**

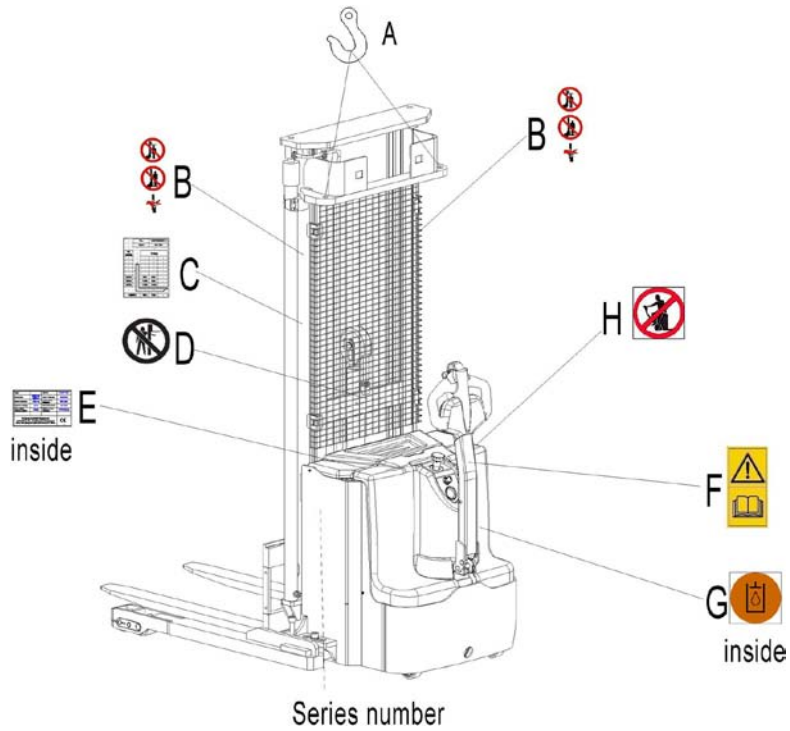

**Fig.1 Label (For EU)**

No.	Art No.	Description	Qty.	Note
A	941200300001	Crane hook label	2	
B	941200100004	Warning decal: Do not step under or on the forks	2	
C	534547520000	Residual lift capacity sticker	1	
D	941200100006	Never reach through	1	
E	534547020001	CE label	1	
F	941200300002	Sticker to read and follow these instructions	1	
G	941200300003	Filling sticker	1	
H	941200300018	'No passengers' decal	1	

**Fig.2 Label (For US)**

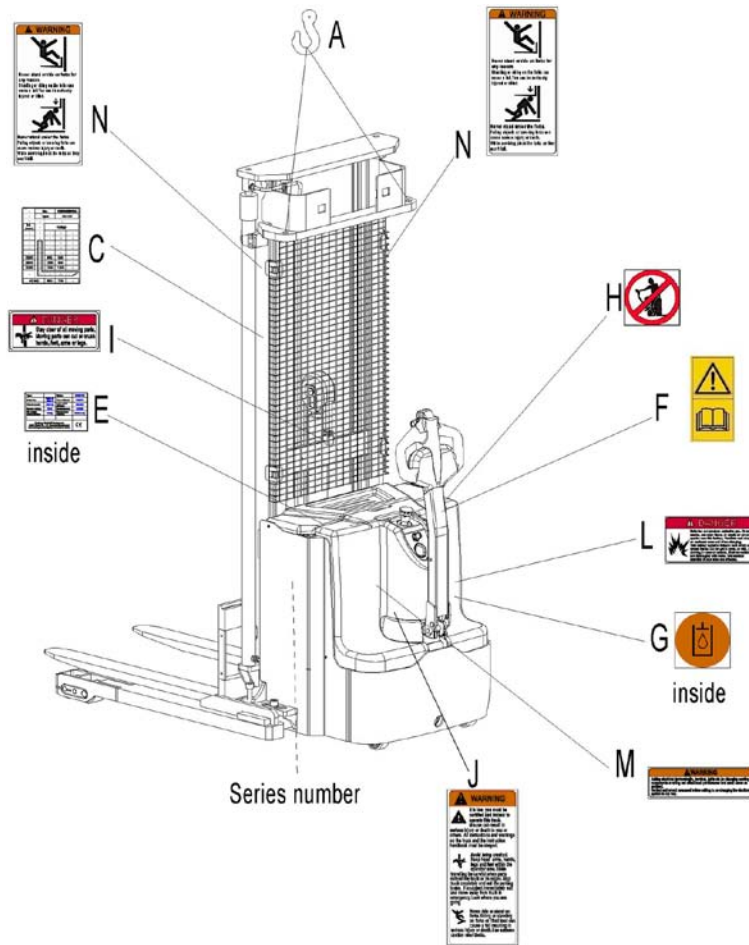

**Fig.2 Label (For US)**

No.	Art No.	Description	Qty.	Note
A	941200300001	Crane hook label	2	
C	534547520000	Residual lift capacity sticker	1	
E	534547020001	CE label	1	
F	941200300002	Sticker to read and follow these instructions	1	
G	941200300003	Filling sticker	1	
H	941200300018	Warning label	1	
I	941200100014	Warning label	1	
J	941200100009	Warning label	1	
L	941200100013	Warning label	1	
M	941200100010	Warning label	1	
N	941200100016	Warning label	1	

**Fig. 3 Fork carriage**

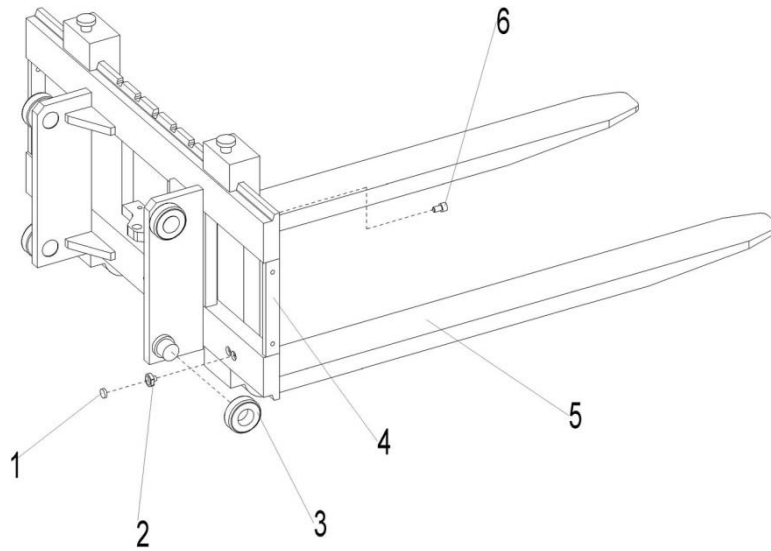

**Fig. 3 Fork carriage**

No.	Art No.	Description	Qty.	Note
1	940600100001	Magnetic steel	1	Φ 18x5
2	940600200001	Magnetic steel base	1	
3	940200300001	Compound roller	4	
4	534538010000	Fork carriage holder welding	1	Two stage full free mast
	534538010001	Fork carriage holder welding	1	Two stage standard mast
5	940100100004	Hook II A type fork	2	
6	910200200074	Screw	3	M10x16

**Fig. 4 Chassis assembly**

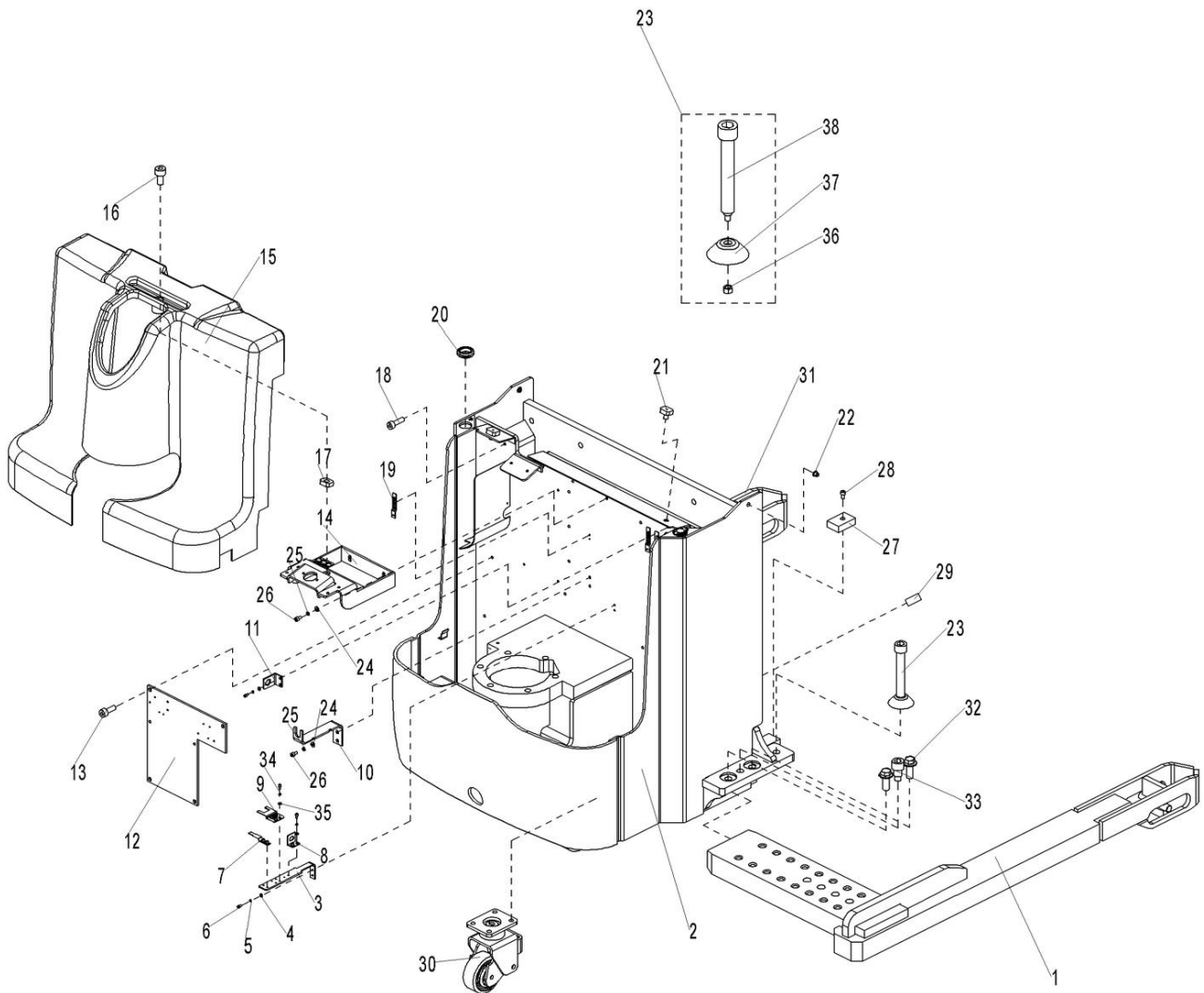
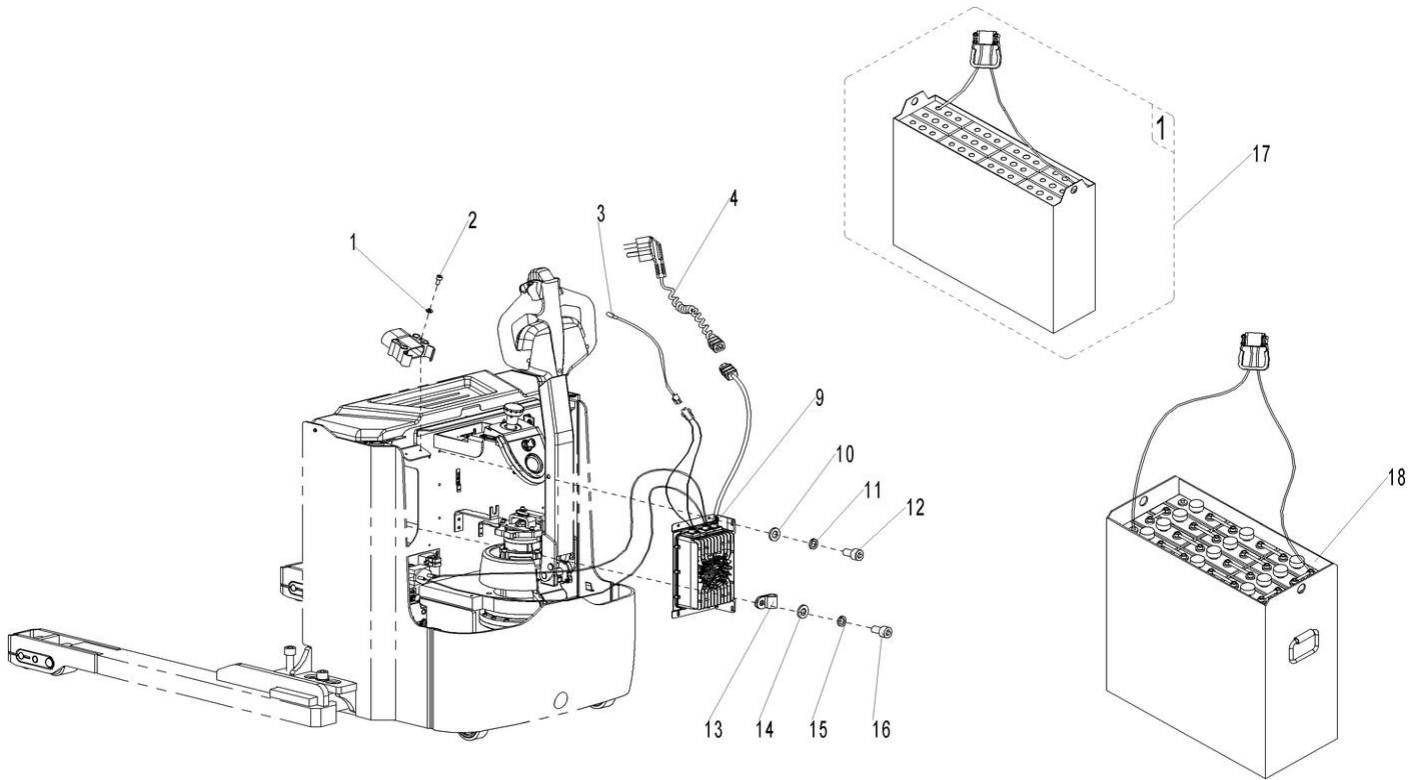

**Fig. 4 Chassis assembly**

No.	Art No.	Description	Qty.	Note
1	534521510002	Leg welding (Right )	1	
2	534521510000	Chassis welding	1	
3	534521520010	Mounting plate (Plug)	1	
4	910400100004	Flat washer	3	5
5	910400500004	Spring washer	3	5
6	910200200022	Screw	2	M5x12
7	921300300010	Connector base	1	
8	921300300003	Connector Fixing frame 4pins	1	
9	921300300015	Connector base	1	
10	534721520025	Fixing frame	1	
11	921300300002	Connector fixing frame 2 pins	1	
12	534821520029	Mounting plate	1	

13	910200200053	Screw	4	M8x12
14	534521510001	Mounting plate welding	1	
15	505021520003	Protective cover (Electrical box)	1	
16	941100100006	Screw	1	M10x45
17	940400400003	Floating nut	1	M10-t(3-5)
18	910200200058	Screw	2	M8x25
19	921300300005	Connector 2 pins base	6	
20	505621520036	Protective bushing	1	
21	505938520016	Damping pad	2	
22	534721520023	Sleeve	2	
23	532621510013	Supporting components	2	
24	910400100006	Flat washer	4	8
25	910400500006	Spring washer	4	8
26	910200200055	Screw	4	M8x16
27	534721520024	Damping pad	2	60x40x18
28	910200300017	Screw	2	M6x12
29	910200800042	Screw	6	M16x40
30	505616510000	Support roller assembly	2	
31	534521510003	Leg welding (Left)	1	
32	910100800006	Bolt	12	M16x40
33	532621520047	Position pin	2	
34	910400500003	Spring washer	2	4
35	910400100003	Flat washer	2	4
36	910300500004	Nut	2	M8
37	532621520030	Supporting base	2	
38	532621520029	Screw	2	

**Fig. 5 Power supply (built-in charger)**



**Fig. 5 Power supply (built-in charger)**

No.	Art No.	Description	Qty.	Note
1	910400100005	Flat washer	2	6
2	910200200039	Screw	2	M6x30
3	922000100020	Light -750	1	
4	921500200031	Spring cord	1	US
	921500200008	Spring cord	1	Asia
	921500200005	Spring cord	1	EU
	921500200003	Spring cord	1	AUS
	921500200004	Spring cord	1	ENG
5	921000100045	Charger	1	WT24V25A
6	910400100005	Flat washer	4	6
7	910400500005	Spring washer	4	6
8	910200200033	Screw	4	M6x12
9	921300200001	Cable fixing part UC-1	4	



10	910400100003	Flat washer	4	4
11	910400500003	Spring washer	4	4
12	910200500034	Screw	4	M4x8
13	534437010000	Traction battery 24V-2PZB180	1	Weld type
14	534437010001	Traction battery 24V-2PZB180	1	Bolt type

**Fig. 6 Instrument components**

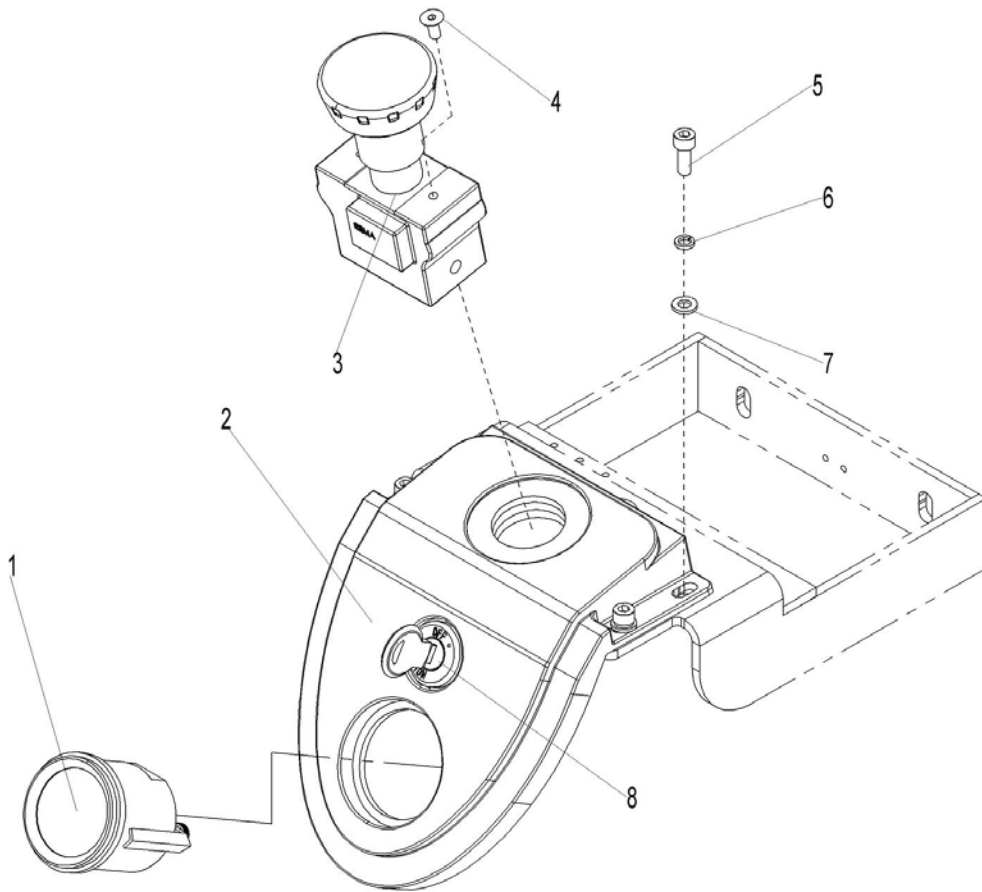

**Fig. 6 Instrument components**

No.	Art No.	Description	Qty.	Note
1	921100100012	Instrument	1	MDI-CAN-12V
2	504410020001	Protective cover (Instrument)	1	
3	920200100001	Emergency button	1	ZDK32-350
4	910200400011	Screw	2	M5x12
5	910200200035	Screw	4	M6x16
6	910400500005	Spring washer	4	6
7	910400100005	Flat washer	4	6
8	505634010000	Key switch	1	

**Fig. 7 Battery cover assembly**

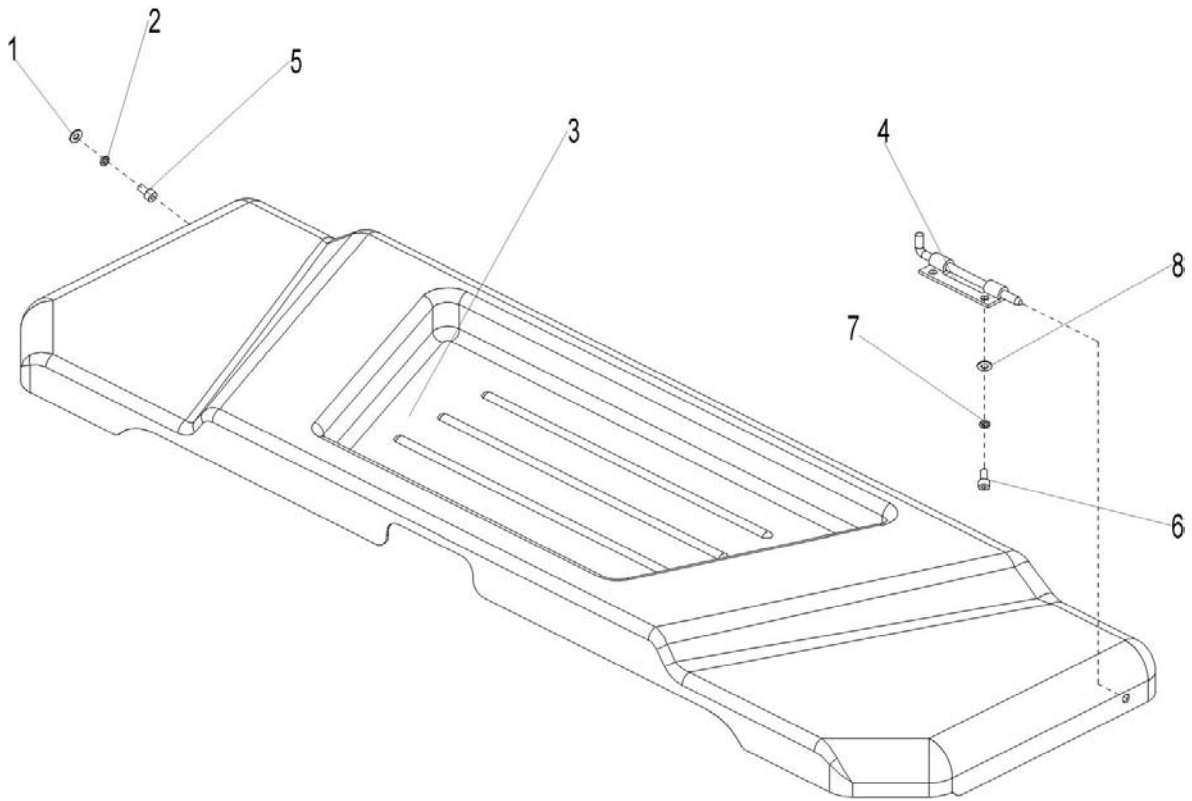

**Fig. 7 Battery cover assembly**

No.	Art No.	Description	Qty.	Note
1	910400100004	Flat washer	3	5
2	910400500004	Spring washer	3	5
3	534821010000	Battery cover welding	1	
4	940800900001	Pin	1	CL037
5	910200200024	Screw	1	M5x20
6	910200200013	Screw	2	M4x10
7	910400500003	Spring washer	2	4
8	910400100003	Flat washer	2	4

Fig. 8 Support wheel components

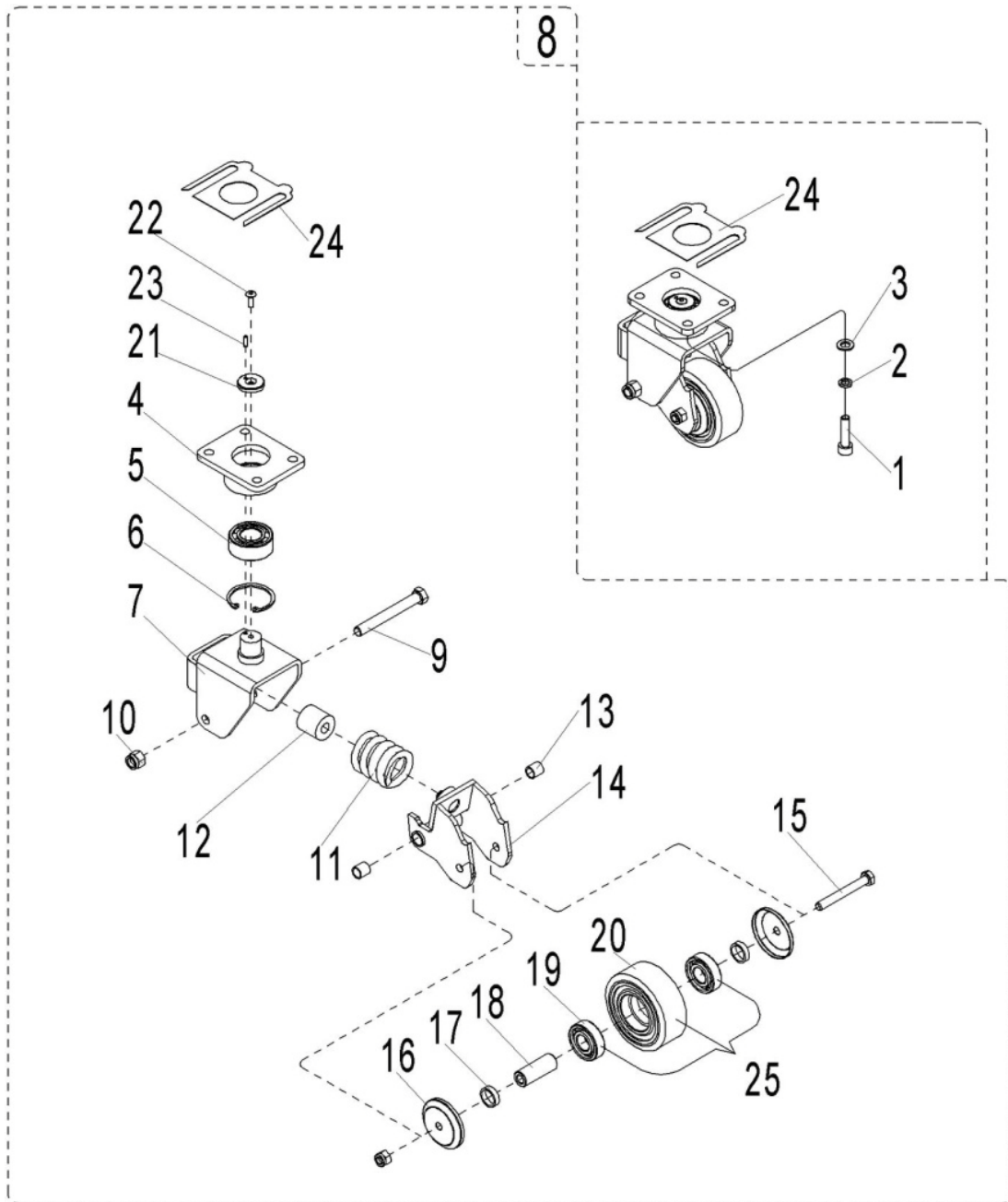

**Fig. 8 Support wheel components**

No.	Art No.	Description	Qty.	Note
1	910200200076	Screw	8	M10x25
2	910400500007	Spring washer	8	10
3	910400100007	Flat washer	8	10
4	505616510002	Connecting plate	2	
5	910700500002	Bearing	2	3205A-2RS
6	910401400016	Circlip	2	52
7	505616510001	Wheel frame welding	2	
8	505616510000	Support roller assembly	2	
9	941100200002	Bolt	2	M12x100
10	910300500006	Nut	2	M12
11	940400500007	Spring	2	Φ43XΦ9x62
12	505616520000	PU spring	2	
13	940500100002	Bushing	4	
14	505616510003	Rotate arm	2	
15	910100100038	Bolt	2	M10x80
16	505616520011	Dust cover	4	
17	505616520012	Circlip	4	
18	505616520013	Sleeve	2	
19	910700200019	Bearing	4	6204-2RS
20	940300300018	Roller	2	
21	505616520007	Circlip	2	
22	941100300001	Screw	2	M6x14
23	910600100004	Cylindrical pin	2	4x14
24	505616520014	Adjusting washer	Several	t=0.5~2.5
25	505698510000	Wheel set components	2	

**Fig. 9 Two-stage mast system (full free lift)**

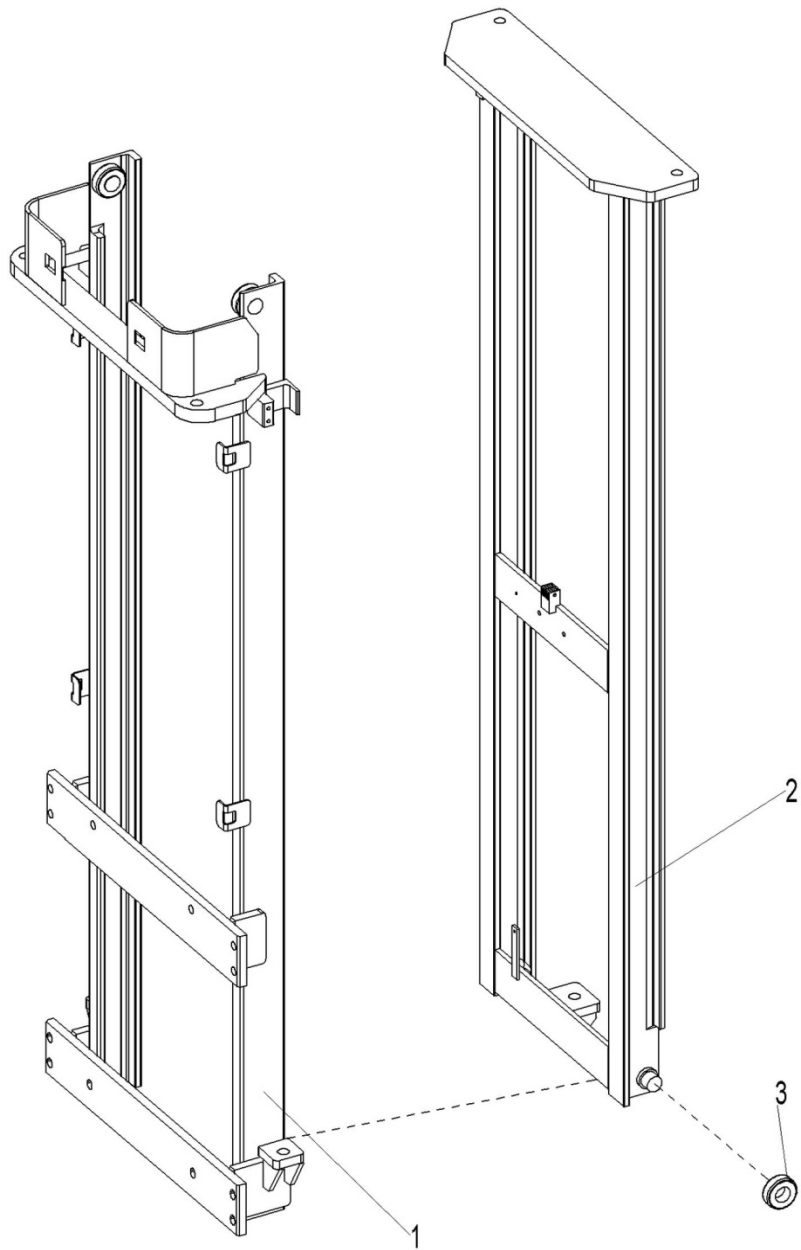

**Fig. 9 Two-stage mast system (full free lift)**

No.	Art No.	Description	Qty.	Note
1	534443510000	Outer mast	1	142
	534443510002	Outer mast	1	126
	534443510004	Outer mast	1	114
2	534443510001	Inner mast	1	142
	534443510003	Inner mast	1	126
	534443510005	Inner mast	1	114
3	940200300001	Compound roller	1	

**Fig. 10 Two-stage mast system (standard lift)**

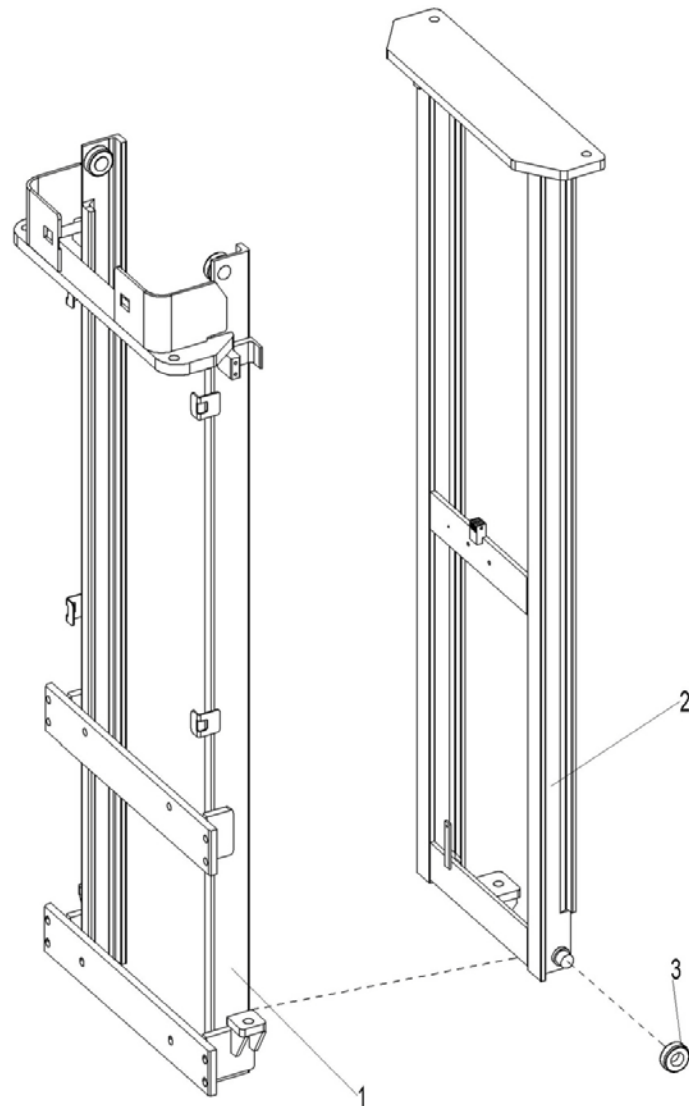

**Fig. 10 Two-stage mast system (standard lift)**

No.	Art No.	Description	Qty.	Note
1	534444010009	Outer mast	1	142
	534444010011	Outer mast	1	126
	534444010013	Outer mast	1	114
2	534444010010	Inner mast	1	142
	534444010012	Inner mast	1	126
	534444010014	Inner mast	1	114
4	940200300001	Compound roller	4	

**Fig. 11 Two-stage mast chain system (full free lift)**

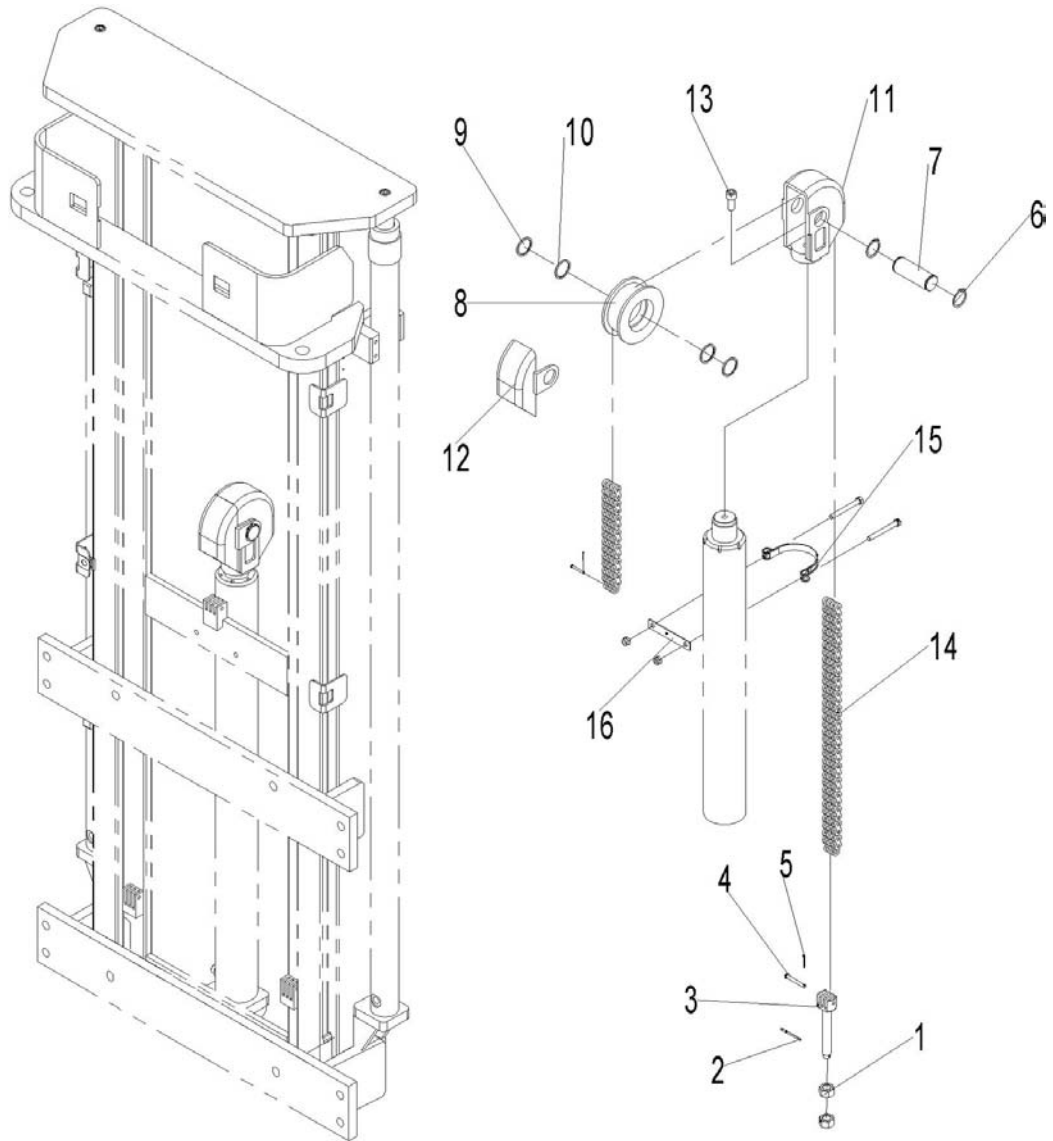
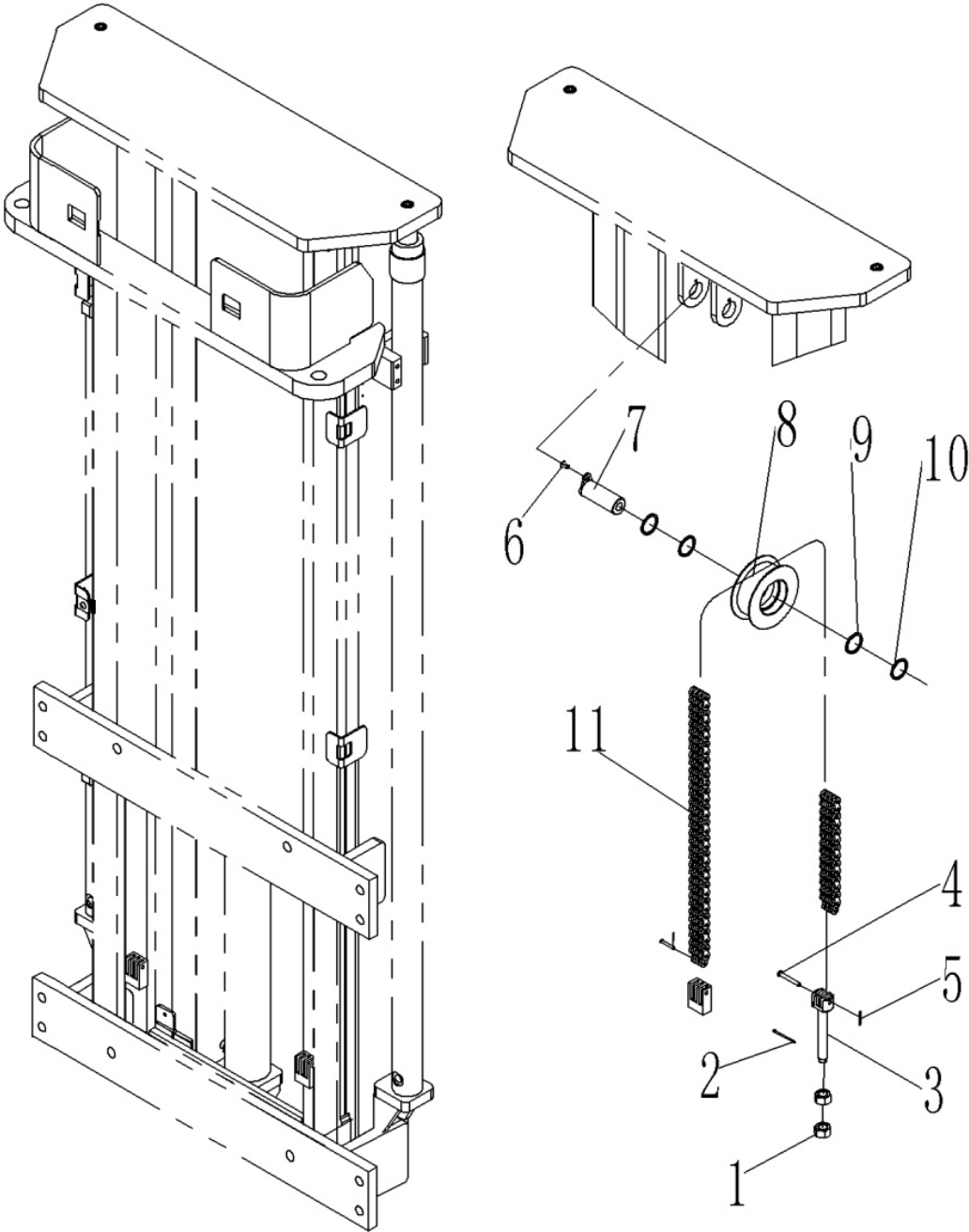



**Fig. 11 Two-stage mast chain system (full free lift)**

No.	Art No.	Description	Qty.	Note
1	910300200008	Nut	2	M16x1.5
2	910600600032	Split pin	1	3.2x40
3	941300100008	Chain bolt	1	M16x1.5x130
4	941100800006	Short axle	2	B6x45
5	910600600015	Split pin	2	2x20
6	910401300016	Circlip	2	30
7	532644520037	Wheel axle	1	
8	940200500010	Chain pulley bearing	1	
9	940600500008	Washer	2	
10	940600500009	Washer	2	
11	532644520035	Chain pulley base	1	
12	532644520036	Side cover	1	
13	910200200097	Screw	1	M12x25
14	532644510079	Chain LH1066-89	1	142
	534744510024	Chain LH1066-83	1	126
	251044510096	Chain LH1066-77	1	114
15	940800600002	Hoop components	1	中心距 96
16	534744520014	Washer (Middle cylinder )	1	

**Fig. 12 Two-stage mast chain system (standard lift)**



**Fig. 12 Two-stage mast chain system (standard lift)**

No.	Art No.	Description	Qty.	Note
1	910300200008	Nut	2	M16x1.5
2	910600600032	Split pin	2	3.2x40
3	941300100008	Chain Bolt	1	M16x1.5x130
4	941100800006	Short axle	2	B6x45
5	910600600015	Split pin	1	2x20
6	910200400016	Screw	1	M6x12
7	533544510006	Axle with plate	1	
8	940200500010	Chain pulley bearing	1	
9	940600500008	Washer	2	Thickness 2
10	940600500009	Washer	2	Thickness 4
11	534444010025	Chain LH1046-139	1	142
	534444010026	Chain LH1046-127	1	126
	534444010024	Chain LH1046-117	1	114

Fig. 13 Mast and other parts

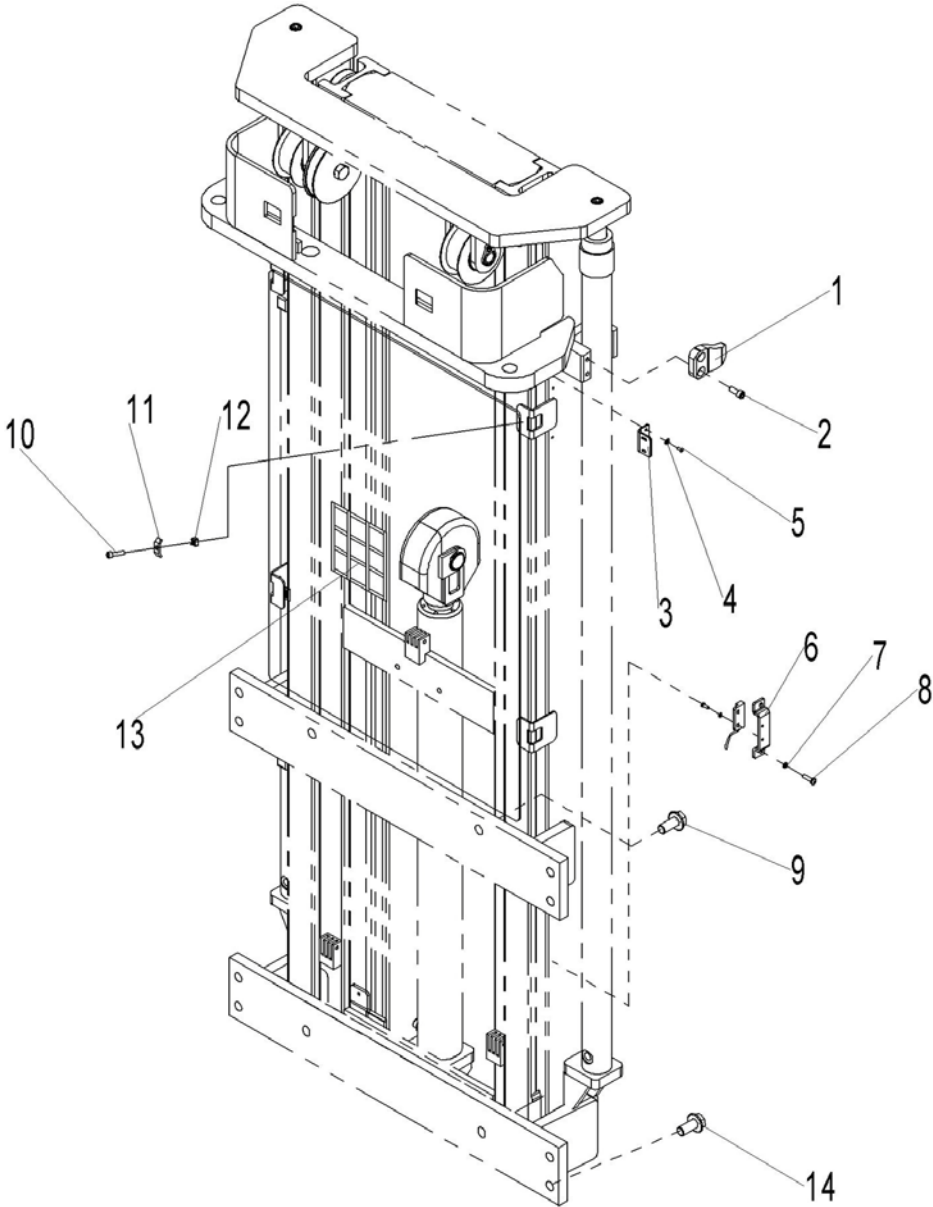

**Fig. 13 Mast and other parts**

No.	Art No.	Description	Qty.	Note
1	275044020076	Metal plate	2	
2	910200200057	Screw	4	M8x20
3	534744520036	Fixing plate	1	
4	910400100003	Flat washer	2	4
5	910200300005	Screw	2	M4x8
6	534744520059	Protective cover	2	
7	910400500003	Spring washer	4	4
8	910200200014	Screw	4	M4x12
9	910100800005	Bolt	4	M16x35
10	910200200038	Screw	4 or 6	M6x25
11	320443020321	Metal plate	4 or 6	
12	940801500001	Nut	4 or 6	M6
13	534444020020	Protective mesh	1	142
	534444020021	Protective mesh	1	126
	534444020022	Protective mesh	1	114
14	910100800006	Bolt	8	M16x40

**Fig. 14 Two-stage mast hydraulic system (full free lift)**

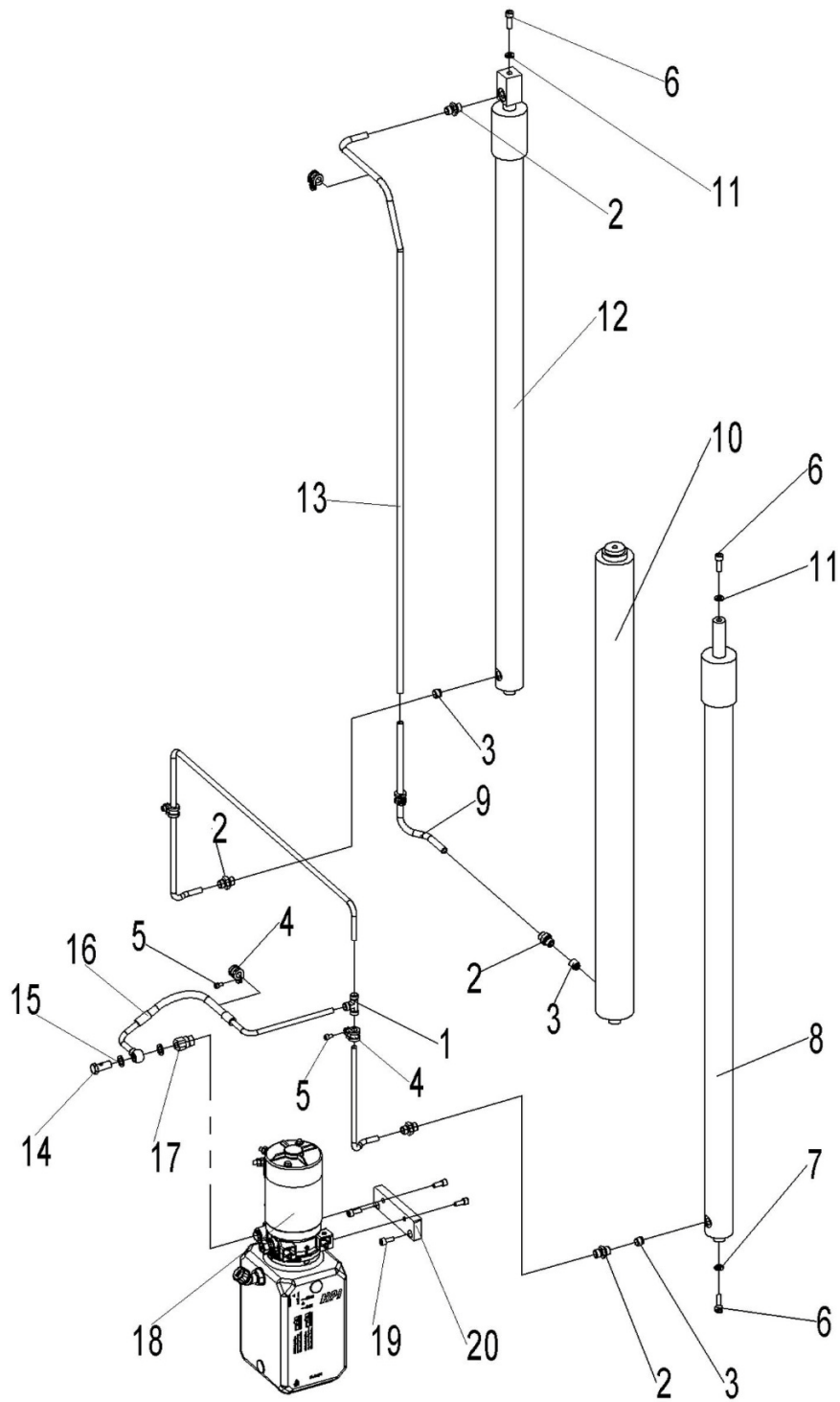

**Fig. 14 Two-stage mast hydraulic system (full free lift)**

No.	Art No.	Description	Qty.	Note
1	950400900002	Joint	1	M16x1.5
2	950400400003	Joint	3	M16x1.5
3	950600300001	Safety valve	3	M16x1.5
4	951000100001	Clamp YGE rubber	5	12
5	910200200032	Screw	5	M6x10
6	910200200097	Screw	4	M12x25
7	534744520015	Washer	2	
8	534743510012	Cylinder (R)	1	142
	534743510013	Cylinder (R)	1	126
	534743510014	Cylinder (R)	1	114
9	534743510018	Hydraulic pipe welding	1	
10	534743510009	Cylinder (M)	1	142
	534743510010	Cylinder (M)	1	126
	534743510011	Cylinder (M)	1	114
11	910400500008	Spring washer	2	12
12	534743510006	Cylinder (L)	1	142
	534743510007	Cylinder (L)	1	126
	534743510008	Cylinder (L)	1	114
13	534743510015	Hydraulic pipe welding	1	142
	534743510016	Hydraulic pipe welding	1	126
	534743510017	Hydraulic pipe welding	1	114
14	911300300001	Hinge bolt	1	G1/4x28.5
15	910800900003	Washer	2	14
16	534524010000	Hydraulic hose assembly	1	
17	950401200003	Joint	1	G3/8-G1/4
18	950900100014	Hydraulic power unit	1	24V1.5KW2.0cc
19	910200200057	Screw	4	M8x20
20	534524020000	Mounting plate	1	

**Fig. 15 Two-stage mast hydraulic system (standard lift)**

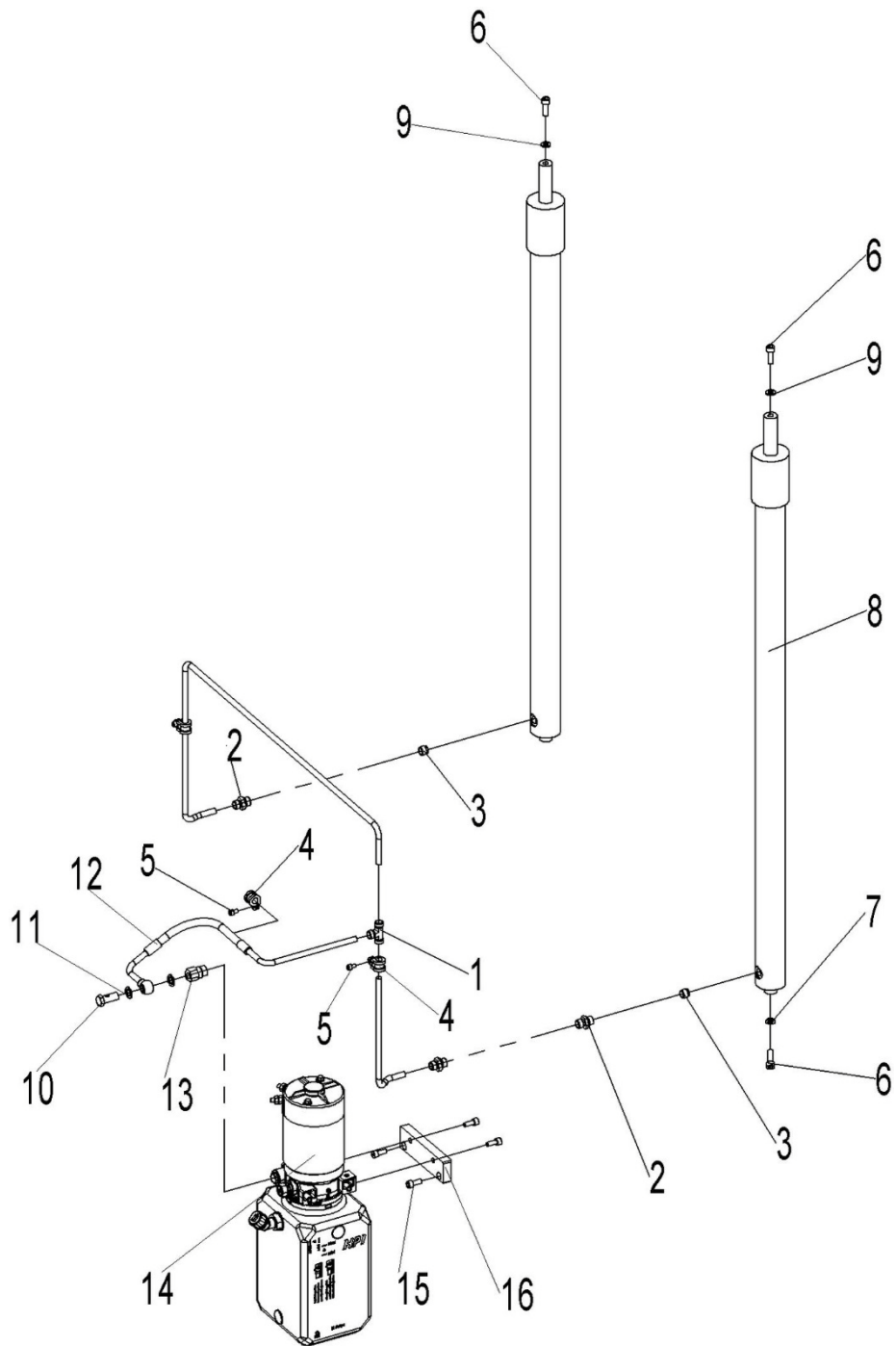
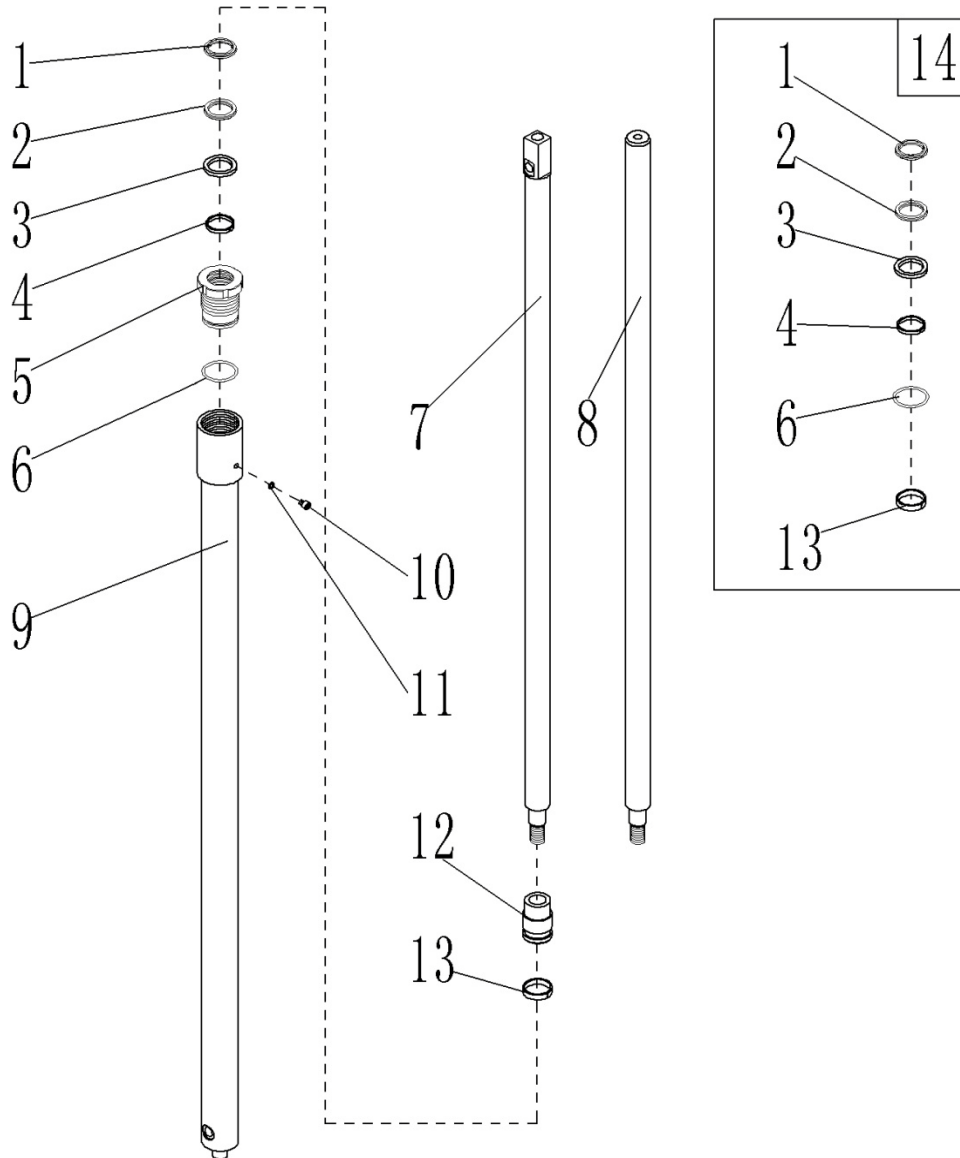



**Fig. 15 Two-stage mast hydraulic system (standard lift)**

No.	Art No.	Description	Qty.	Note
1	950400900002	Joint	1	M16x1.5
2	950400400003	Joint	3	M16x1.5
3	950600300001	Safety valve	3	M16x1.5
4	951000100001	Clamp YGE rubber	3	12
5	910200200032	Screw	3	M6x10
6	910200200097	Screw	4	M12x25
7	534744520015	Washer	2	
8	534444010006	Cylinder	2	142
	534444010007	Cylinder	2	126
	534444010008	Cylinder	2	114
9	910400500008	Spring washer	2	12
10	911300300001	Hinge Bolt	1	G1/4x28.5
11	910800900003	Washer	2	14
12	534524010000	Hydraulic hose assembly	1	
13	950401200003	Joint	1	G3/8-G1/4
14	950900100014	Hydraulic power unit	1	24V1.5KW2.0cc
15	910200200057	Screw	4	M8x20
16	534524020000	Mounting plate	1	

**Fig. 16 Two-stage mast outer cylinder assembly (full free lift)**

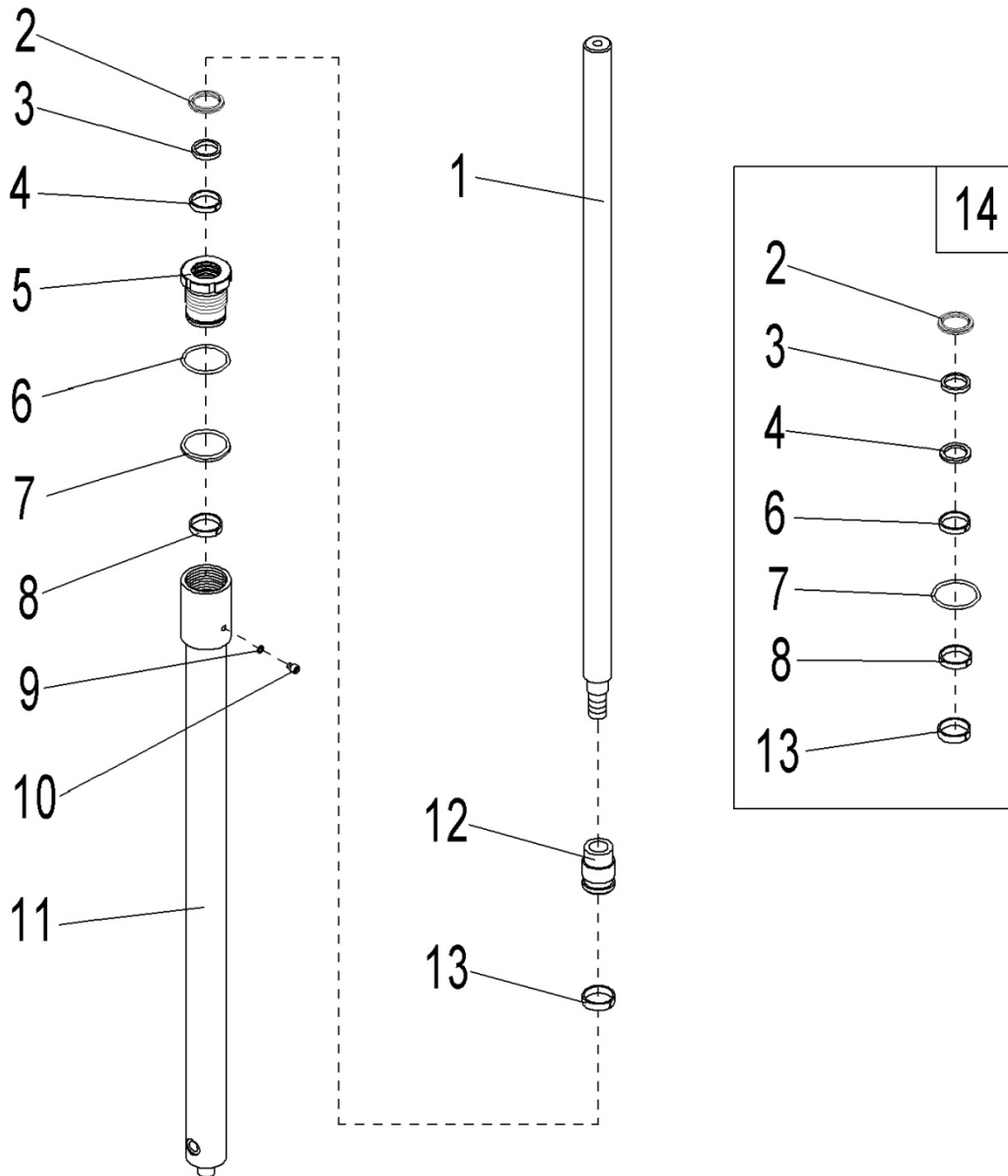

**Fig. 16 Two-stage mast outer cylinder assembly (full free lift)**

No.	Art No.	Description	Qty.	Note
1	534798520027	Dust ring	1	
2	534798520028	Seal ring	1	
3	534798520029	Sealing	1	
4	534798520030	Supporting ring	1	

5	534798520031	Cap	1	
6	910800100093	O ring	1	
7	534798520032	Piston rod	1	142 Left cylinder
	534798520033	Piston rod	1	126 Left cylinder
	534798520034	Piston rod	1	114 Left cylinder
8	534798520035	Piston rod	1	142 Right cylinder
	534798520036	Piston rod	1	126 Right cylinder
	534798520037	Piston rod	1	114 Right cylinder
9	534798520038	Cylinder tube	1	142
	534798520039	Cylinder tube	1	126
	534798520040	Cylinder tube	1	114
10	910800900010	Washer	1	8
11	910200200051	Screw	1	M8x10
12	534798520041	Piston	1	
13	533298520004	Supporting ring	1	
14	534798510002	Sealing components	1	

**Fig. 17 Two-stage mast middle cylinder assembly (full free lift)**



**Fig. 17 Two-stage mast middle cylinder assembly (full free lift)**

No.	Art No.	Description	Qty.	Note
1	534798520059	Piston rod	1	142
	534798520060	Piston rod	1	126
	534798520061	Piston rod	1	114
2	534798520042	Dust ring	1	
3	534798520063	Circlip	1	
4	534798520064	Seal ring	1	
5	534798520065	End cap	1	
6	534498520021	O ring	1	
7	534798520066	Circlip	1	
8	534798520067	Supporting ring	1	
9	910800900010	Washer	1	8
10	910200200051	Screw	1	M8x10
11	534798520068	Cylinder tube	1	142
	534798520069	Cylinder tube	1	126
	534798520070	Cylinder tube	1	114
12	534798520071	Piston	1	
13	534798520072	Supporting ring	1	
14	534798510003	Sealing components	1	

**Fig. 18 Two-stage mast outer cylinder assembly (standard lift)**

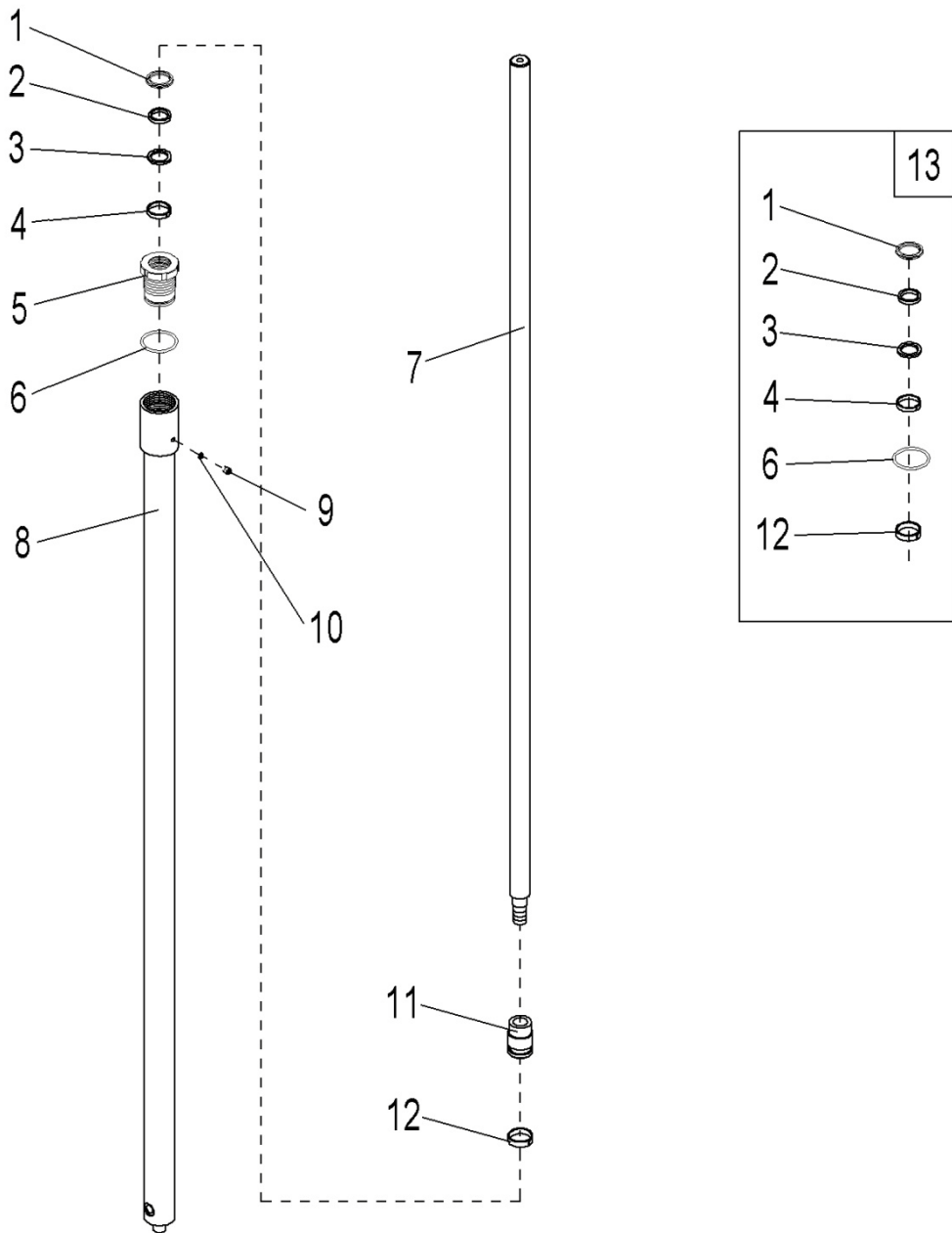

**Fig. 18 Two-stage mast outer cylinder assembly (standard lift)**

No.	Art No.	Description	Qty.	Note
1	910800400002	Dust ring	1	
2	535398520002	Seal ring	1	
3	535098520017	Sealing	1	
4	535398520003	Supporting ring	1	
5	534798520046	Cap	1	
6	910800100093	O ring	1	
7	534798520047	Piston rod	1	142
	534798520048	Piston rod	1	126
	534798520049	Piston rod	1	114
8	534798520050	Cylinder tube	1	142
	534798520051	Cylinder tube	1	126
	534798520052	Cylinder tube	1	114
9	910200200051	Screw	1	M8x10
10	910800900010	Washer	1	8
11	534798520041	Piston	1	
12	533298520004	Supporting ring	1	
13	534798510005	Sealing components	1	

**Fig. 19 Drive system assembly**

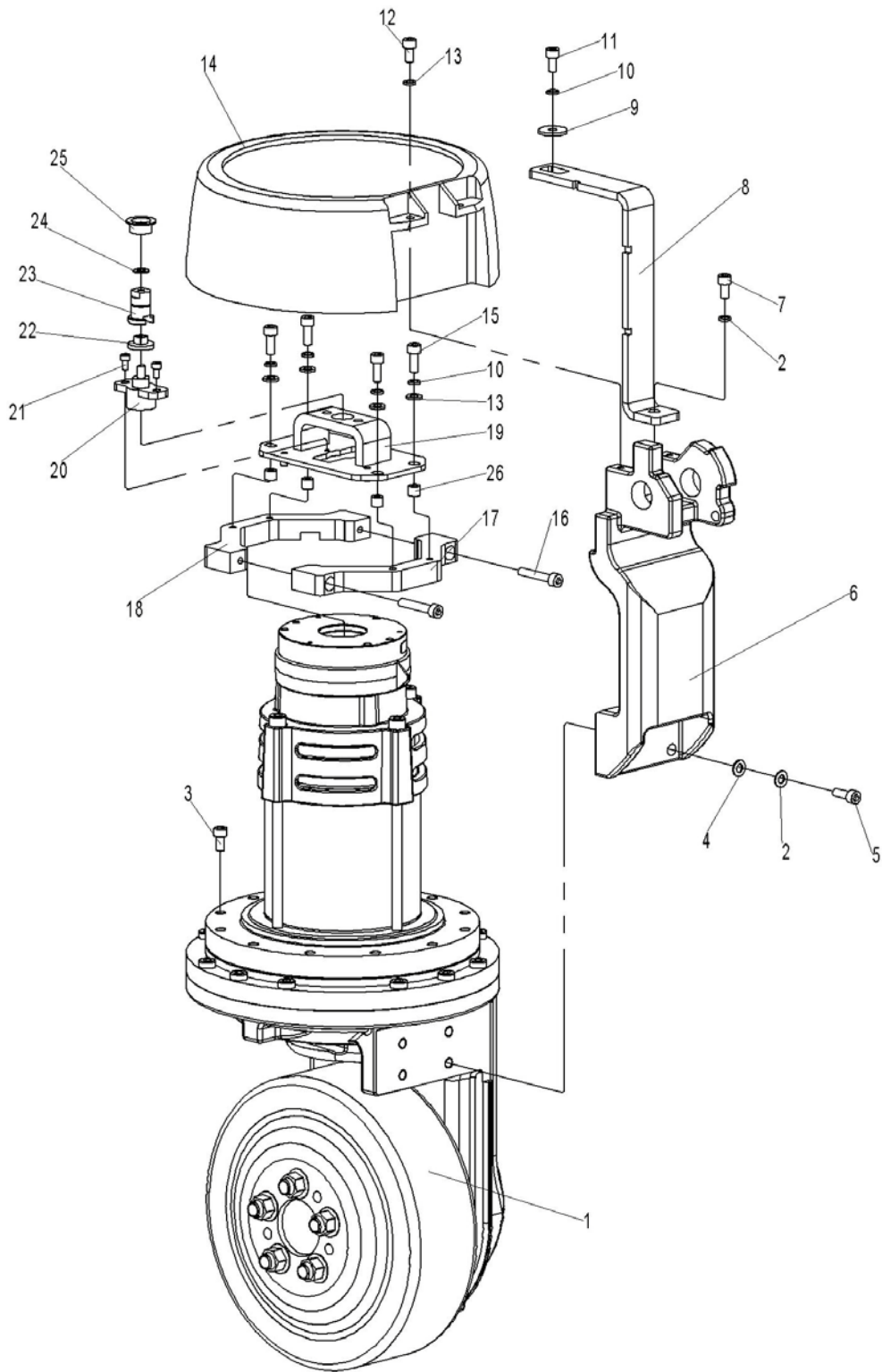
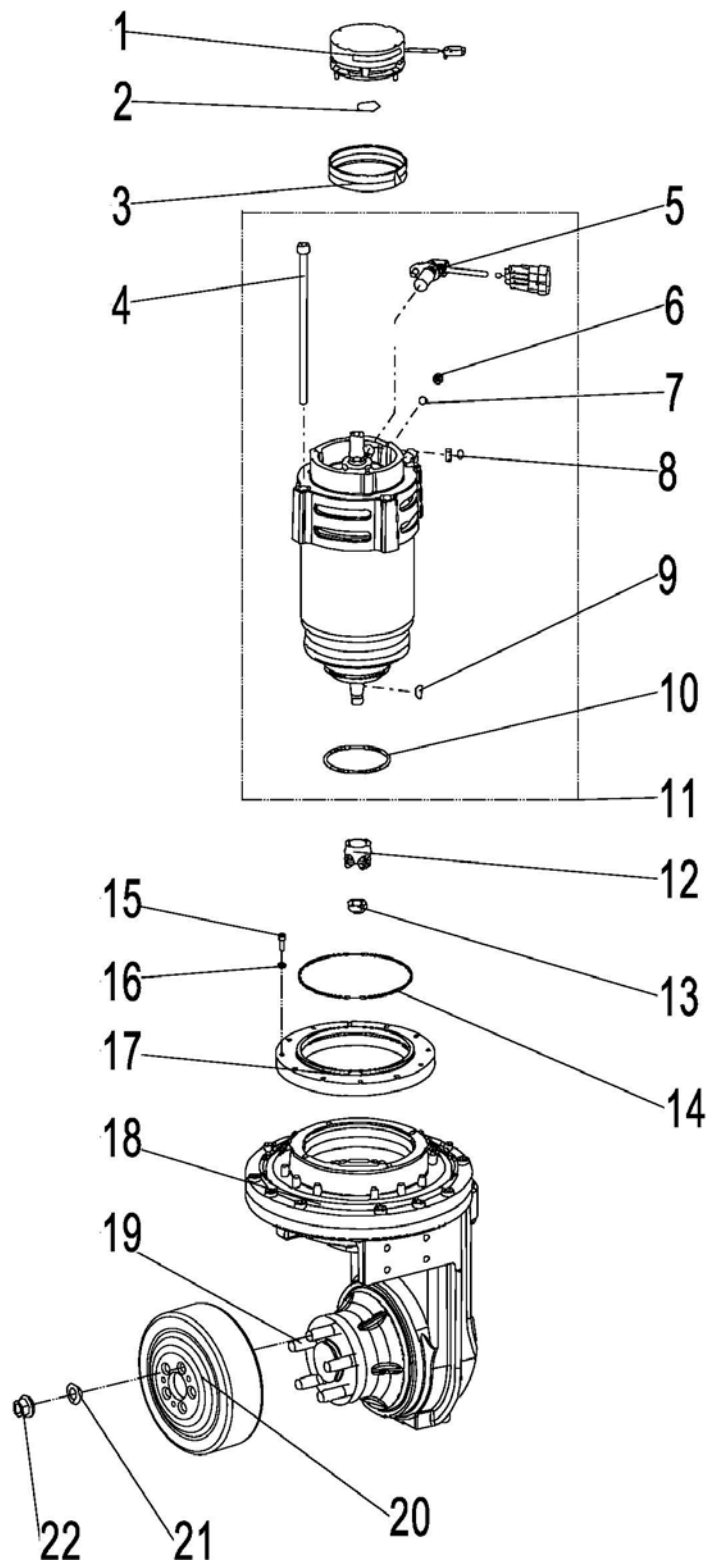



**Fig. 19 Drive system assembly**

No.	Art No.	Description	Qty.	Note
1	940900400004	Driving assembly	1	
2	910400500006	Spring washer	5	8
3	910200200061	Screw	6	M8x40
4	910400100006	Flat washer	4	8
5	910200200058	Screw	4	M8x25
6	534813520000	Tiller base	1	
7	910200200055	Screw	1	M8x16
8	534813520006	Connecting rod	1	
9	534813520008	Washer	1	Thickness 2
10	910400500005	Spring washer	5	6
11	910200200033	Screw	1	M6x12
12	910200300017	Screw	2	M6x12
13	910400100005	Flat washer	6	6
14	534713520003	Protective cover	1	
15	910200200038	Screw	4	M6x25
16	910200200041	Screw	2	M6x40
17	534813520003	Fixing plate	1	
18	534813520002	Fixing plate	1	
19	534813510001	Mounting base welding	1	
20	921800200006	Potentiometer	1	
21	910200200012	Screw	2	M4x8
22	505631520003	Connecting block	1	
23	534813520001	Fixing axle	1	
24	910401300006	Circlip	1	15
25	940500200001	Bushing	1	
26	534813520010	spacer bush	4	

Fig. 20 Driving assembly



**Fig. 20 Driving assembly**

No.	Art No.	Description	Qty.	Note
1	535998510001	Brake	1	
2	535998520000	Circlip	1	15
3	535998520001	Spacer	1	
4	535998520002	Screw	4	M8x175
5	535998510002	Sensor	1	
6	535998520003	Nut	1	M6x8
7	535998520004	Safety components	1	
8	535998520005	Flat key	1	5x5x14
9	535998520006	Semi-circle key	1	
10	535998520007	O ring	1	
11	535998510003	Motor	1	
12	535998520014	Gear	1	
13	535998520008	Nut	1	
14	535998520009	O ring	1	146x3
15	910200200060	Screw	9	M8x35
16	910400500006	Spring washer	9	8
17	535998520010	Mounting plate	1	
18	535998510004	Mounting box assembly	1	
19	535998520011	Stud	5	
20	940300400005	Roller	1	Φ 230x70
21	535998520012	Spring washer	5	
22	535998520013	Nut	5	

**Fig. 21 Load wheel assembly**

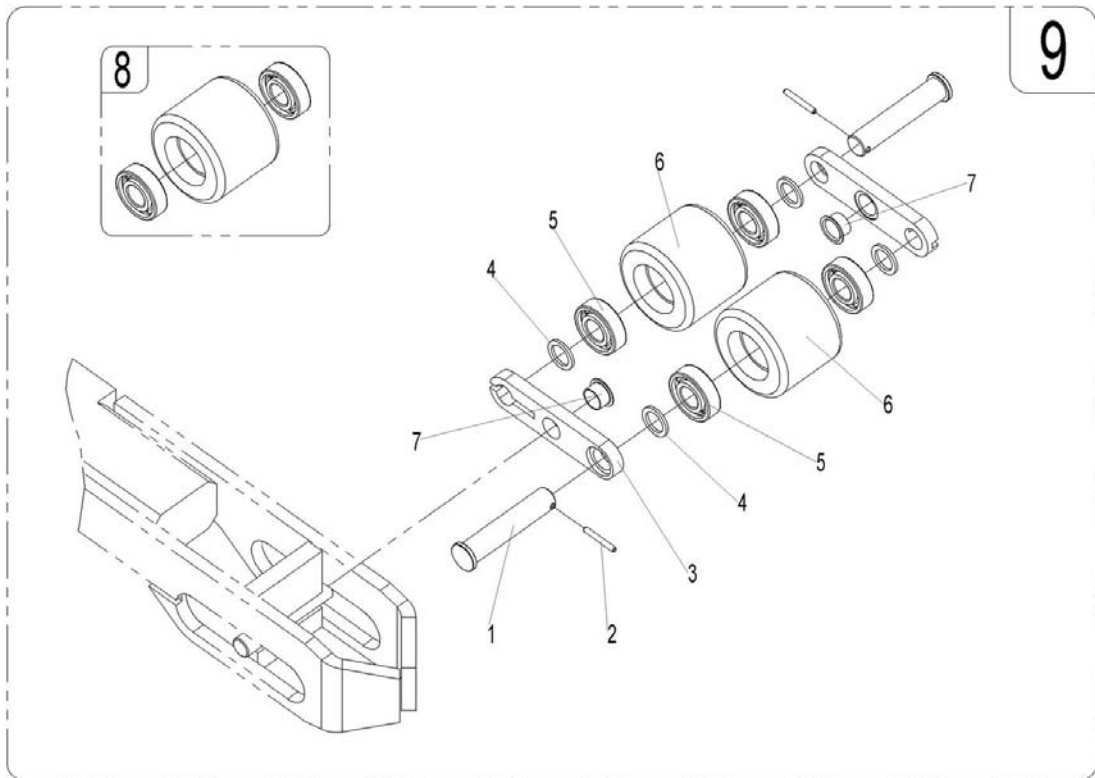

**Fig. 21 Load wheel assembly**

No.	Art No.	Description	Qty.	Note
1	534717020001	Short axle	2	
2	910600400017	Cylindrical pin	2	4x35
3	534717020002	Connecting plate	2	
4	940600500004	Washer	4	
5	910700200019	Bearing	4	6204-2RS
6	940300300009	Roller	2	
7	940500200003	Bushing	2	
8	532998510001	Wheel set components	4	
9	534717001001	Load roller assembly	2	

**Fig. 22 Tiller assembly**

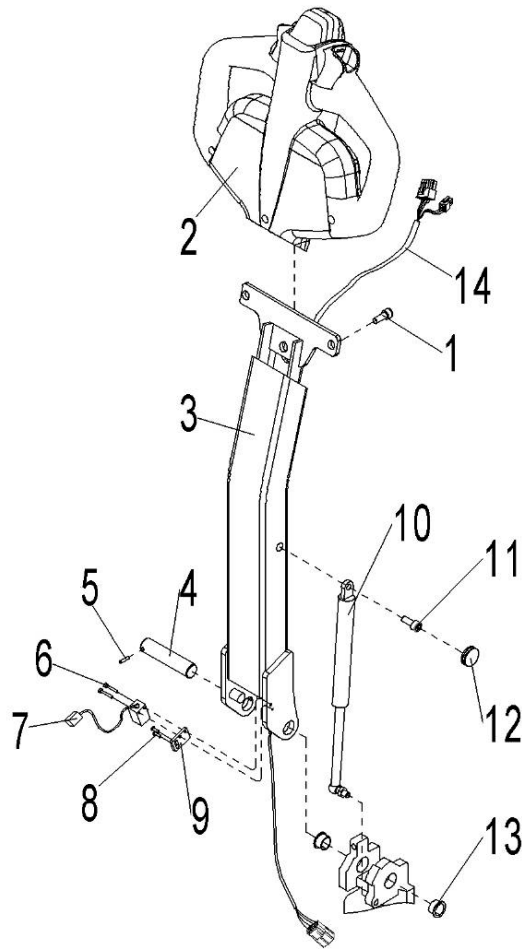

**Fig. 22 Tiller assembly**

No.	Art No.	Description	Qty.	Note
1	910200200058	Screw	2	M8x25
2	922100100001	Tiller 94300-90(REMA)	1	
3	504411010001	Tiller arm	1	
4	504411020011	Rotate axle	1	
5	910600400009	Cylindrical pin	1	4x14
6	910200200005	Screw	2	M3x20
7	505633510002	Proximity switch	1	
8	910200200014	Screw	2	M4x12
9	504411020009	Base plate	1	
10	940400100011	Air spring	1	
11	910200200057	Screw	1	M8x20
12	502311020009	Sleeve	1	
13	940500200005	Bushing	2	20x22x12
14	534833010001	Tiller control wiring harness	1	

**Fig. 23 Pump system**

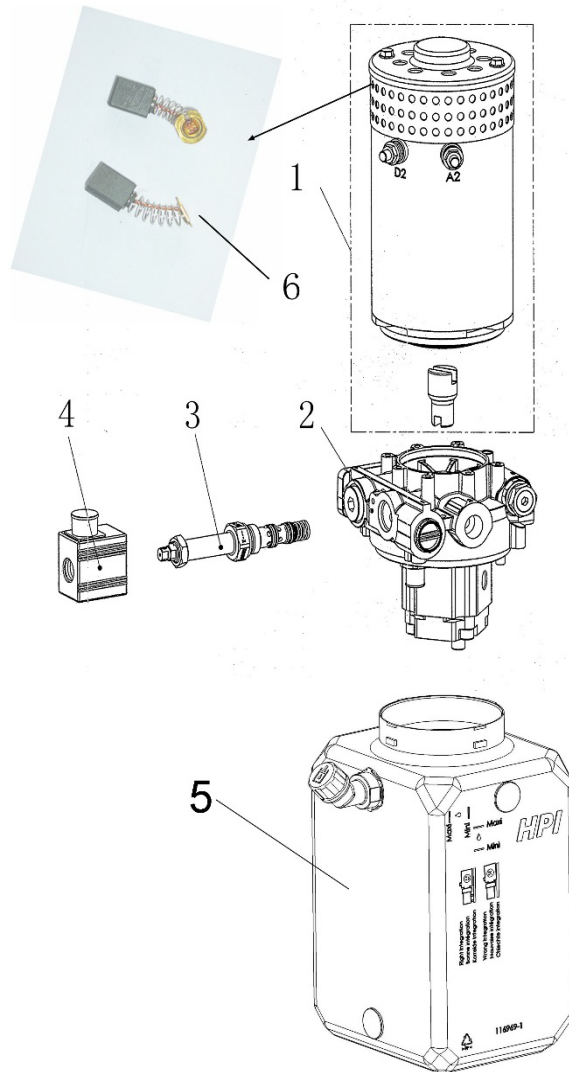

**Fig. 23 Pump system**

No.	Art No.	Description	Qty.	Note
1	534498510003	Motor	1	1.5KW
2	534498510004	Centre valve block	1	
3	534498510005	Electromagnetic valve pins	1	
4	534498510006	Coil	1	
5	534498510007	Oil tank	1	
6	534498510008	Carbon brush	1	

**Fig. 24 Main circuit wiring harness**

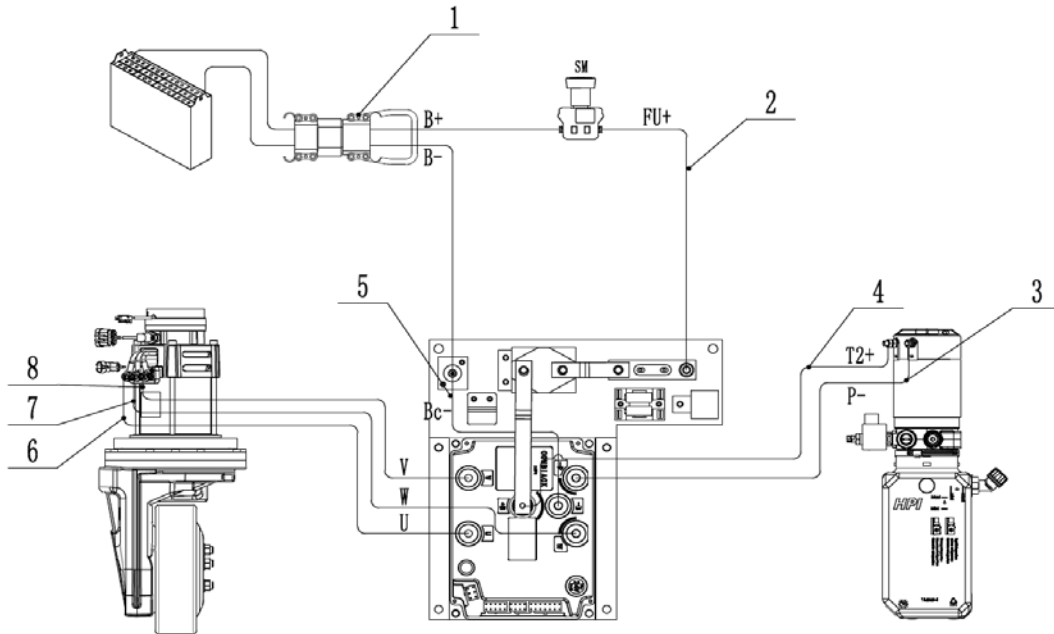

**Fig. 24 Main circuit wiring harness (manual steering)**

No.	Art No.	Description	Qty.	Note
1	534833010008	Main power supply wiring harness	1	
2	534833010009	Cable	1	FU+
3	534533010006	Cable	1	P-
4	534533010007	Cable	1	T2+
5	534833010013	Cable	1	BC-
6	534833010003	Cable	1	U
7	534833010005	Cable	1	W
8	534833010004	Cable	1	V

**Fig. 25 Electrical parts**

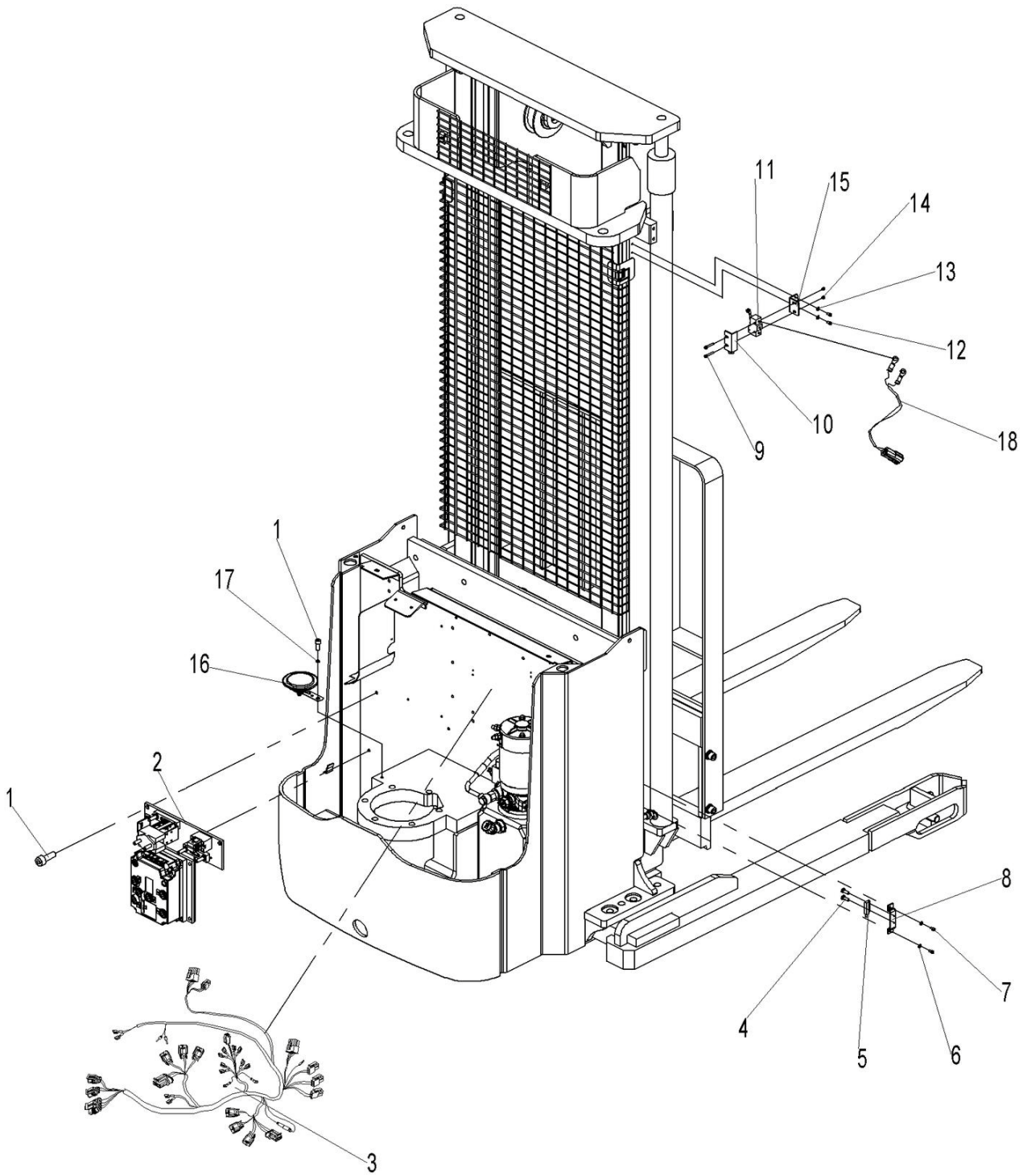
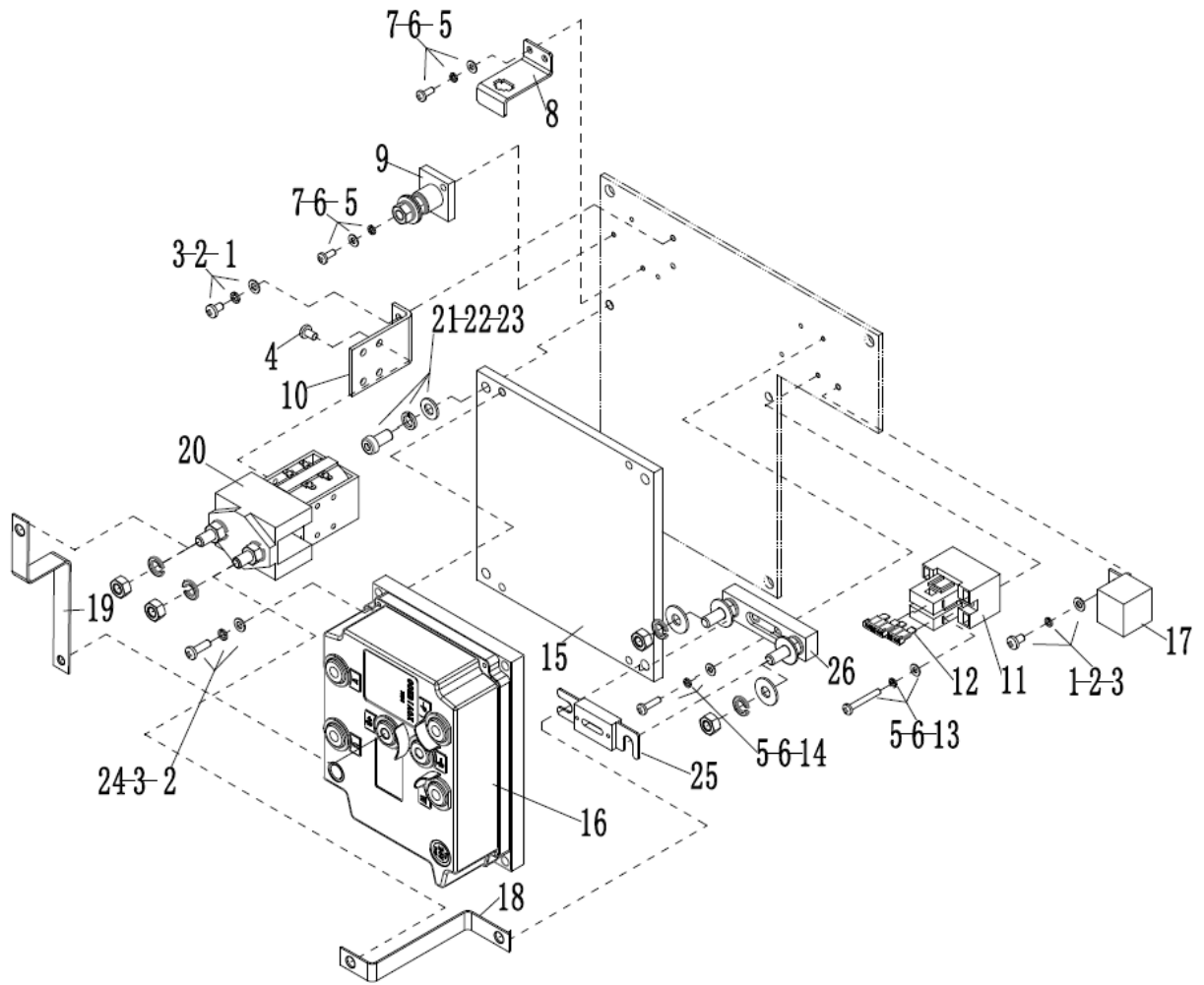



**Fig. 25 Electrical parts**

No.	Art No.	Description	Qty.	Note
1	910200200053	Screw	5	M8x12
2	534833501000	Electrical parts assembly (COMBIACX)	1	
3	534533010000	Main control wiring harness (COMBIACX regular)	1	
4	910200500010	Screw	2	M3x8
5	534833510003	Magnetic switch	1	HWK23
6	910400500003	Spring washer	2	4
7	910200200014	Screw	2	M4x12
8	534744520059	Protective cover	1	
9	910200400006	Screw	2	M4x25
10	920200300008	Micro switch protective cover	1	
11	920200300001	Micro switch	1	XZ-15GW22-B
12	910200300005	Screw	2	M4x8
13	910400100003	Flat washer	2	4
14	910300500001	Nut	2	M4
15	534744520036	Fixing plate	1	
16	920500100001	Horn	1	
17	910400500006	Spring washer	1	8
18	534833510002	Limit control wiring harness (2150mm)	1	142
	534733010015	Limit control wiring harness (1950mm)	1	126
	534833510001	Limit control wiring harness (1850mm)	1	114

**Fig. 26 Controller components (COMBIACX)**

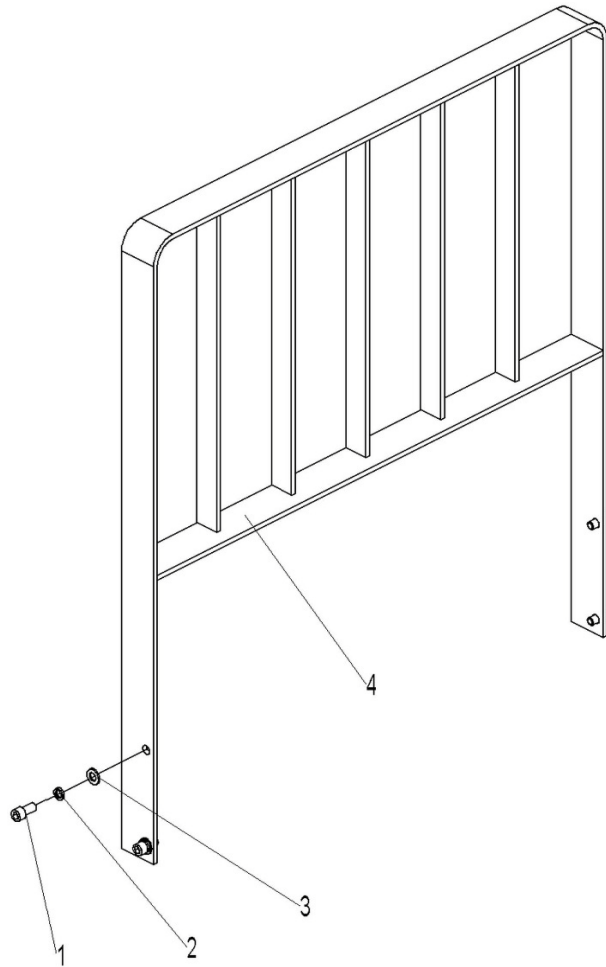

**Fig. 26 Controller components (COMBIACX)**

No.	Art No.	Description	Qty.	Note
1	910200500037	Screw	3	M5x10
2	910400500004	Spring washer	7	5
3	910400100004	Flat washer	7	5
4	910200500036	Screw	2	M5x8
5	910400100003	Flat washer	8	4
6	910400500003	Spring washer	8	4
7	910200500021	Screw	8	4
8	921300300001	Fixing frame	1	
9	920100400001	Fuse base	1	M8
10	921300400004	Main contactor fixing part	1	180
11	920100400005	Fuse base	1	2x10A

12	920100200002	Fuse	2	10A
13	910200500028	Screw	2	M4x30
14	910200500024	Screw	2	M4x16
15	534733020000	Aluminium plate	1	COMBIACX
16	921400100048	Controller	1	24-240+270A
17	920800100001	Relay	1	DC24V
18	534733020002	Copper bar	1	
19	534733020001	Copper bar	1	
20	920700100002	Contactoer	1	DC24V-SW180
21	910400100006	Flat washer	2	8
22	910400500006	Spring washer	2	8
23	910200200055	Screw	2	M8x16
24	910200200023	Screw	4	M5x16
25	920100100013	Fuse	1	350A
26	920100400002	Fuse base	1	SYV

**Fig. 27 Load backrest**



**Fig. 27 Load backrest**

No.	Art No.	Description	Qty.	Note
1	534840510000	Load backrest welding	1	
2	910200200076	Screw	2	M10x25
3	910400100007	Flat washer	4	10
4	910400500007	Spring washer	4	10
5	910200200078	Screw	2	M10x35

### Easy worn part list

No.	Art No.	Description	Qty.	Fig. /Position	Note
1	534721520024	Damping pad	2	Fig. 4/27	Chassis assembly
2	910700500002	Bearing	2	Fig. 8/5	Support roller components
3	940500100002	Bushing	4	Fig. 8/13	
4	910700200019	Bearing	4	Fig. 8/19	
5	940300300018	Roller	2	Fig. 8/20	
6	534798520027	Dust ring	1	Fig. 16/1	
7	534798520028	Seal ring	1	Fig. 16/2	
8	534798520029	Sealing	1	Fig. 16/3	
9	534798520030	Supporting ring	1	Fig. 16/4	
10	910800100093	O ring	1	Fig. 16/6	
11	533298520004	Supporting ring	1	Fig. 16/13	
12	534798510002	Sealing components	1	Fig. 16/14	
13	534798520042	Dust ring	1	Fig. 17/2	Two-stage mast middle cylinder assembly (full free lift)
14	534798520064	Seal ring	1	Fig. 17/4	
15	534498520021	O ring	1	Fig. 17/6	
16	534798520067	Supporting ring	1	Fig. 17/8	
17	534798520072	Supporting ring	1	Fig. 17/13	
18	534798510003	Sealing components	1	Fig. 17/14	
19	910800400002	Dust ring	1	Fig. 18/1	Two-stage mast outer cylinder assembly (standard lift)
20	535398520002	Seal ring	1	Fig. 18/2	
21	535098520017	Sealing	1	Fig. 18/3	
22	535398520003	Supporting ring	1	Fig. 18/4	
23	910800100093	O ring	1	Fig. 18/6	
24	533298520004	Supporting ring	1	Fig. 18/12	
25	534798510005	Sealing components	1	Fig. 18/13	
26	921800200006	Potentiometer	1	Fig. 19/20	Driving assembly
27	940500200001	Bushing	1	Fig. 19/25	
28	910700200019	Bearing	4	Fig. 21/5	Load roller assembly
29	940300300009	Roller	2	Fig. 21/6	
30	940500200003	Bushing	2	Fig. 21/7	
31	532998510001	Wheel set components	4	Fig. 21/8	
32	505633510002	Proximity switch	1	Fig. 22/7	Tiller control assembly
33	940400100011	Air spring	1	Fig. 22/10	
34	502311020009	Sealing $\Phi$ 26	1	Fig. 22/12	
35	940500200005	Bushing	2	Fig. 22/13	

36	534833510003	Magnetic switch	1	Fig. 25/5	Electrical components
37	920200300001	Micro switch	1	Fig. 25/11	
38	920100200002	Fuse	2	Fig. 26/12	Controller components
39	920800100001	Relay	1	Fig. 26/17	
40	920700100002	Contactactor	1	Fig. 26/20	
41	920100100013	Fuse	1	Fig. 26/25	