

## Spare parts list

### Electric Stacker PS13RMPLUS

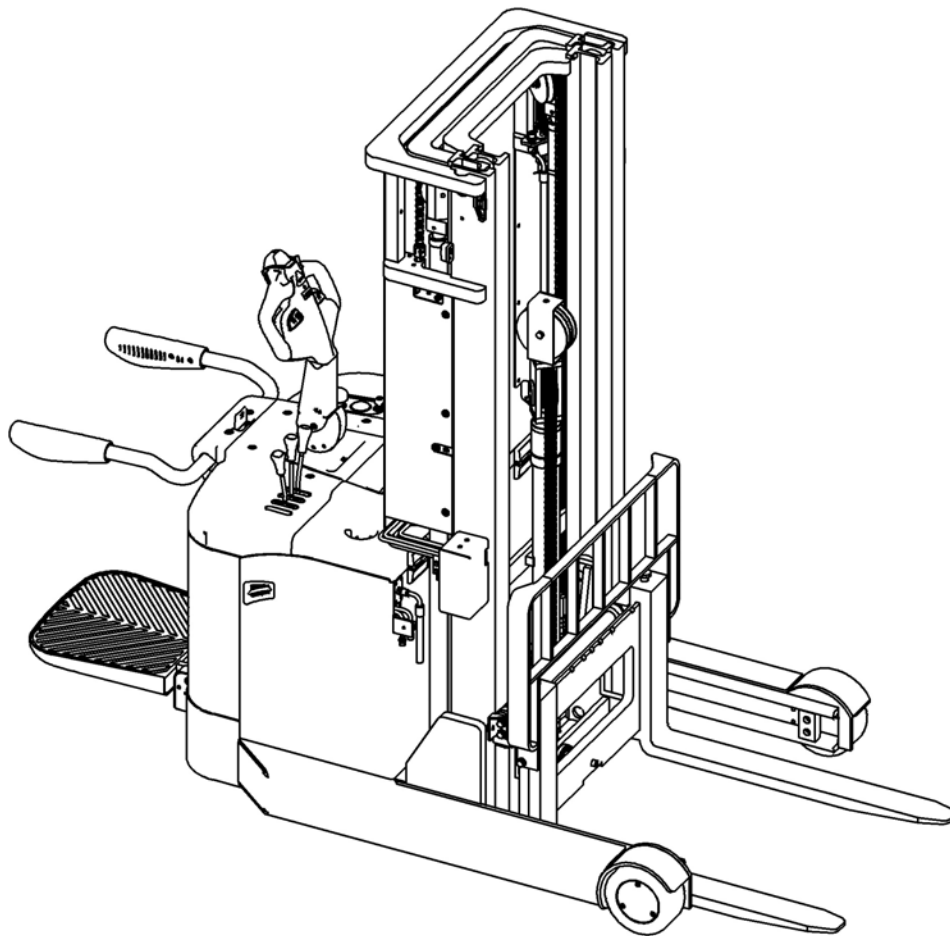

Version 12/2018

From truck identification No.:

PS13RMPLUS-BPT-004-EN

## Catalogue

Fig. 1 Sticker (US).....	3
Fig. 2 Sticker (EU) .....	5
Fig. 3 Appearance (single mast) .....	7
Fig. 4 Appearance (two-stage-mast) .....	8
Fig. 5 Appearance (three-stage-mast) .....	9
Fig. 6 Control panel.....	10
Fig. 7 Indicator assembly .....	12
Fig. 8 Electrical steering assembly .....	14
Fig. 9 Fork frame kits (single mast).....	16
Fig. 10 Fork frame kits (two-stage-mast) .....	18
Fig. 11 Fork frame kits (three-stage-mast) .....	22
Fig. 12 Outer mast kits (single mast) .....	24
Fig. 13 Outer mast kits (two and three stage mast) .....	30
Fig. 14 Inner mast kits (Two stage mast) .....	36
Fig. 15 Middle mast kits (three stage mast) .....	38
Fig. 16 Inner mast kits (three stage mast) .....	40
Fig. 17 Single mast hydraulic pipeline (three ways) .....	44
Fig. 18 Single mast hydraulic pipeline (four ways) .....	46
Fig. 19 Two stage mast hydraulic pipeline (three ways) .....	50
Fig. 20 Two stage mast hydraulic pipeline (four ways) .....	52
Fig. 21 Three stage mast hydraulic pipeline (three ways) .....	54
Fig. 22 Three stage mast hydraulic pipeline (four ways) .....	58
Fig. 23 Drive assembly .....	64
Fig. 24 Cylinder function group .....	68
Fig. 25 Load roller .....	70
Fig. 26 Tiller kits .....	72
Fig. 27 Tiller head .....	74
Fig. 28 Protective arm assembly.....	78
Fig. 29 Platform assembly .....	80

Fig. 30 Battery cover turning structure .....	84
Fig. 31 Steering wheel kits .....	86
Fig. 32 Tilt cylinder .....	88
Fig. 33 Truck body assembly .....	90
Fig. 34 Truck body assembly (sides way) .....	94
Fig. 35 Hydraulic (three ways) .....	100
Fig. 36 Hydraulic (four ways) .....	102
Fig. 37 Forward cylinder .....	106
Fig. 38 Front lifting cylinder .....	108
Fig. 39 Rear lifting cylinder .....	110
Fig. 40 Multi tandem valve (three ways) .....	112
Fig. 41 Multi tandem valve (four ways) .....	116
Fig. 42 Pump system2.2kW .....	118
Fig. 43 Pump system3.0kW .....	120
Fig. 44 Battery .....	122
Fig. 45 Controller components .....	124
Fig. 46 Wiring harness .....	128
Easy worn parts list.....	130

Fig. 1 Sticker (US)

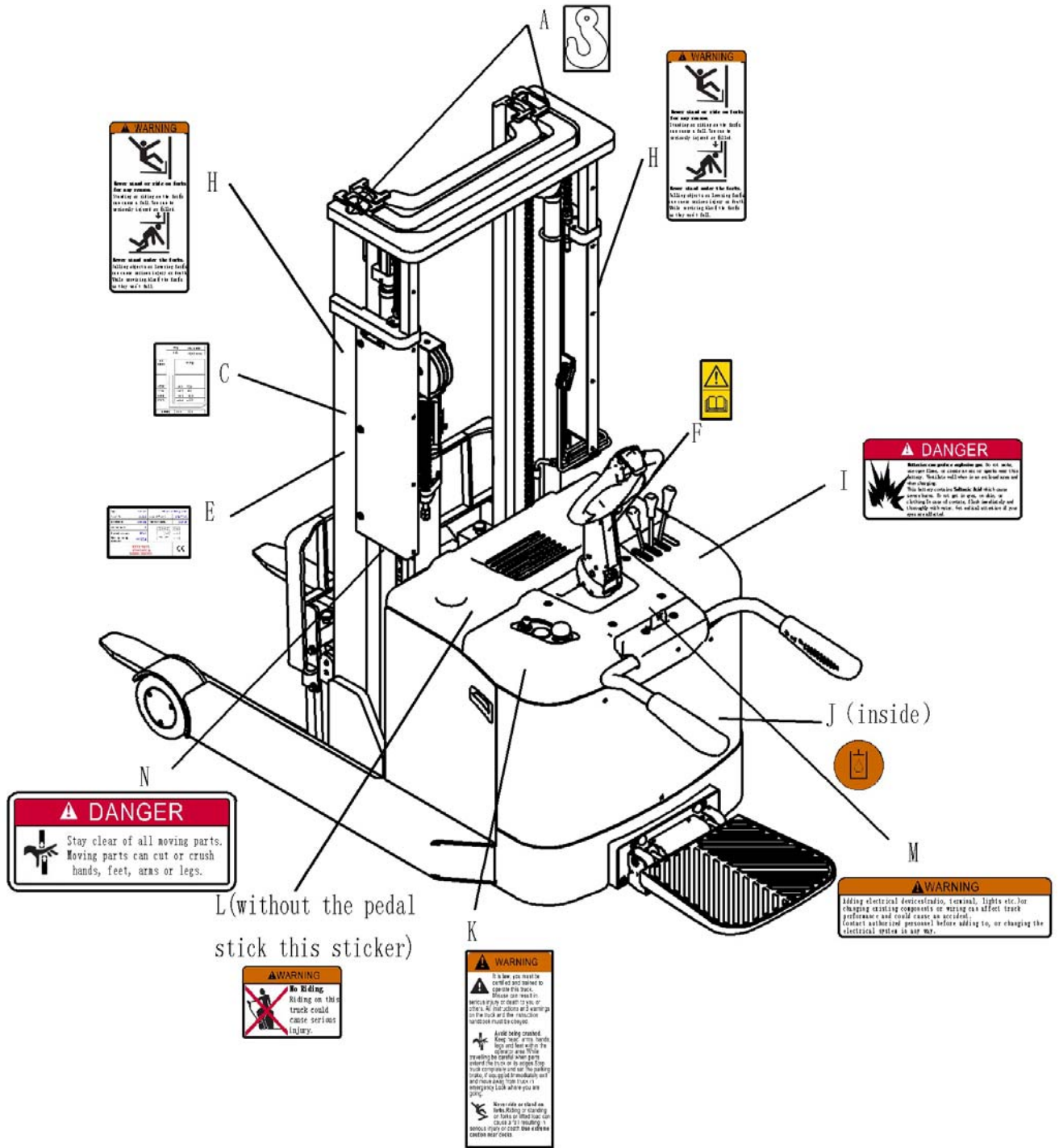

**Fig. 1 Sticker (US)**

No.	Art No.	Description	Qty.	Note
A	941200300001	Hook sticker	2	
C	202047020000	Residual lift capacity sticker	1	
E	202047020001	Identification plate (ID-plate)	1	
F	941200300002	Warning label	1	
H	941200100016	Warning label	2	
I	941200100013	Warning label	1	
J	941200300003	Filling sticker	1	
K	941200100009	Warning label	1	
L	941200100011	Warning label	1	
M	941200100010	Warning label	1	
N	941200100014	Warning label	1	

Fig. 2 Sticker (EU)

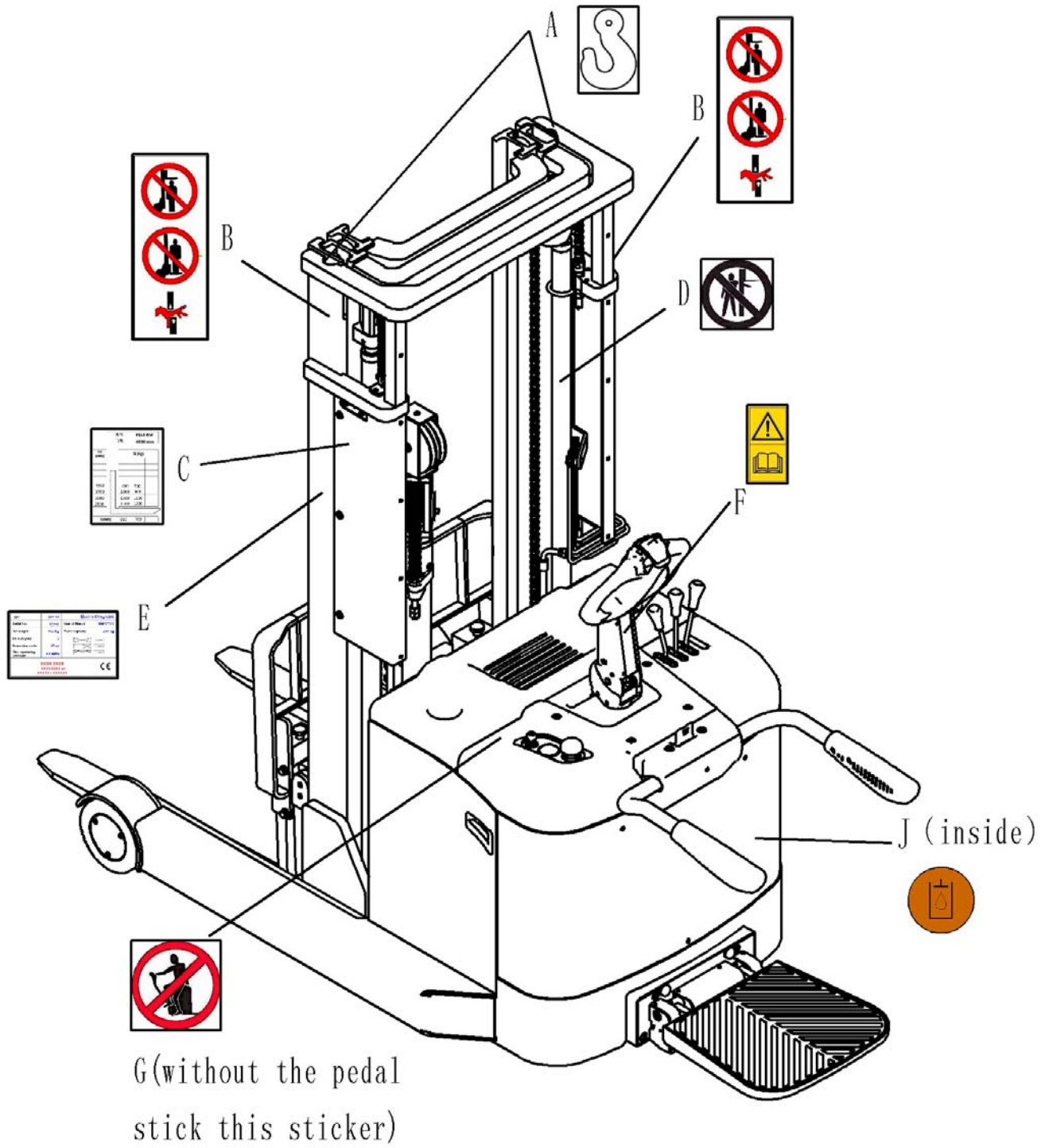

**Fig. 1 Sticker (EU)**

No.	Art No.	Description	Qty.	Note
A	941200300001	Hook sticker	2	
B	941200100004	Warning sticker	2	
C	202047020000	Residual lift capacity sticker	1	
D	941200100006	Warning sticker	1	
E	202047020001	Identification plate	1	
F	941200300002	Warning sticker	1	
G	941200100003	Warning sticker	1	
J	941200300003	Filling sticker	1	

Fig. 3 Appearance (single mast)

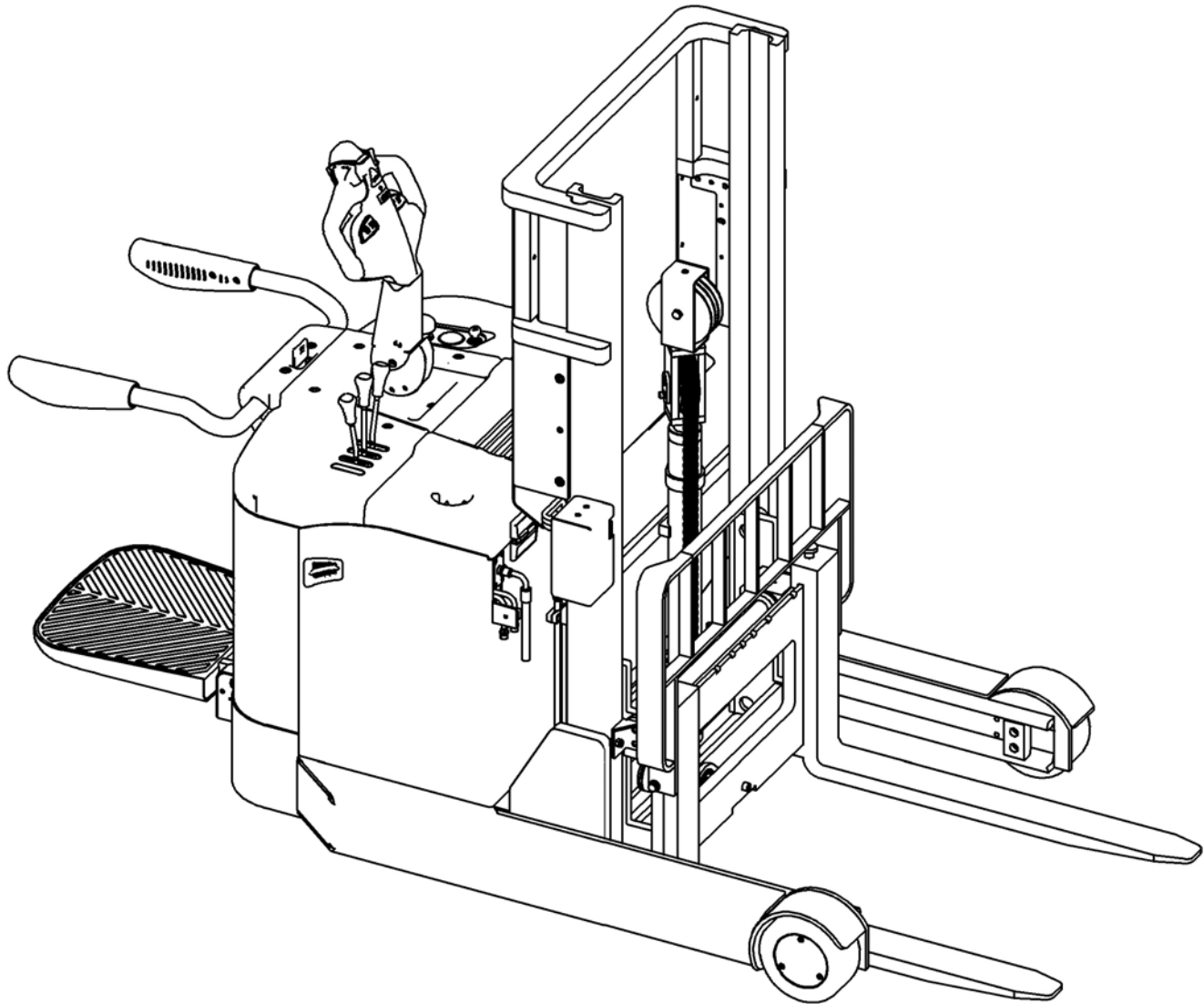



Fig. 4 Appearance (two-stage-mast)

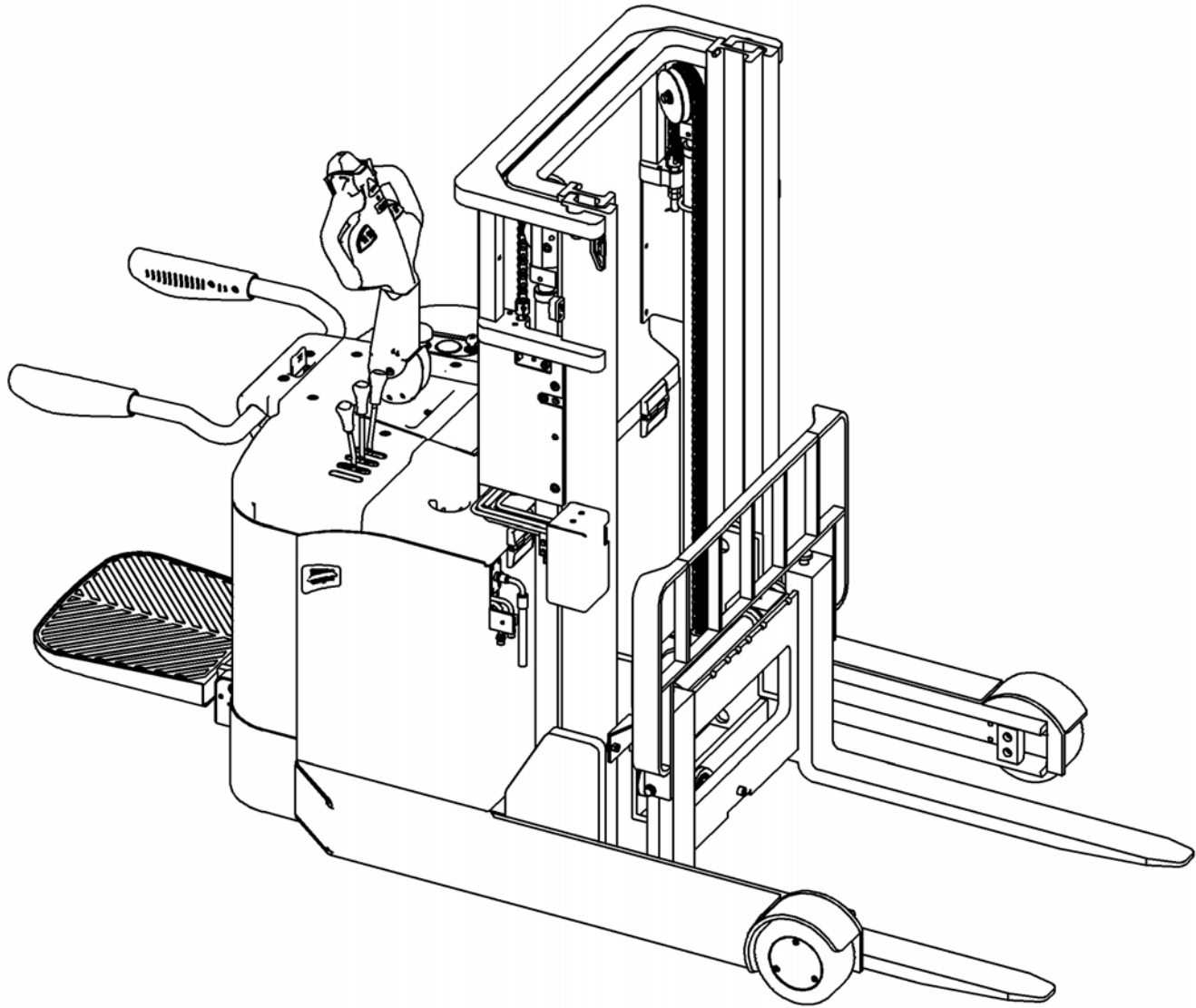

Fig. 5 Appearance (three-stage-mast)

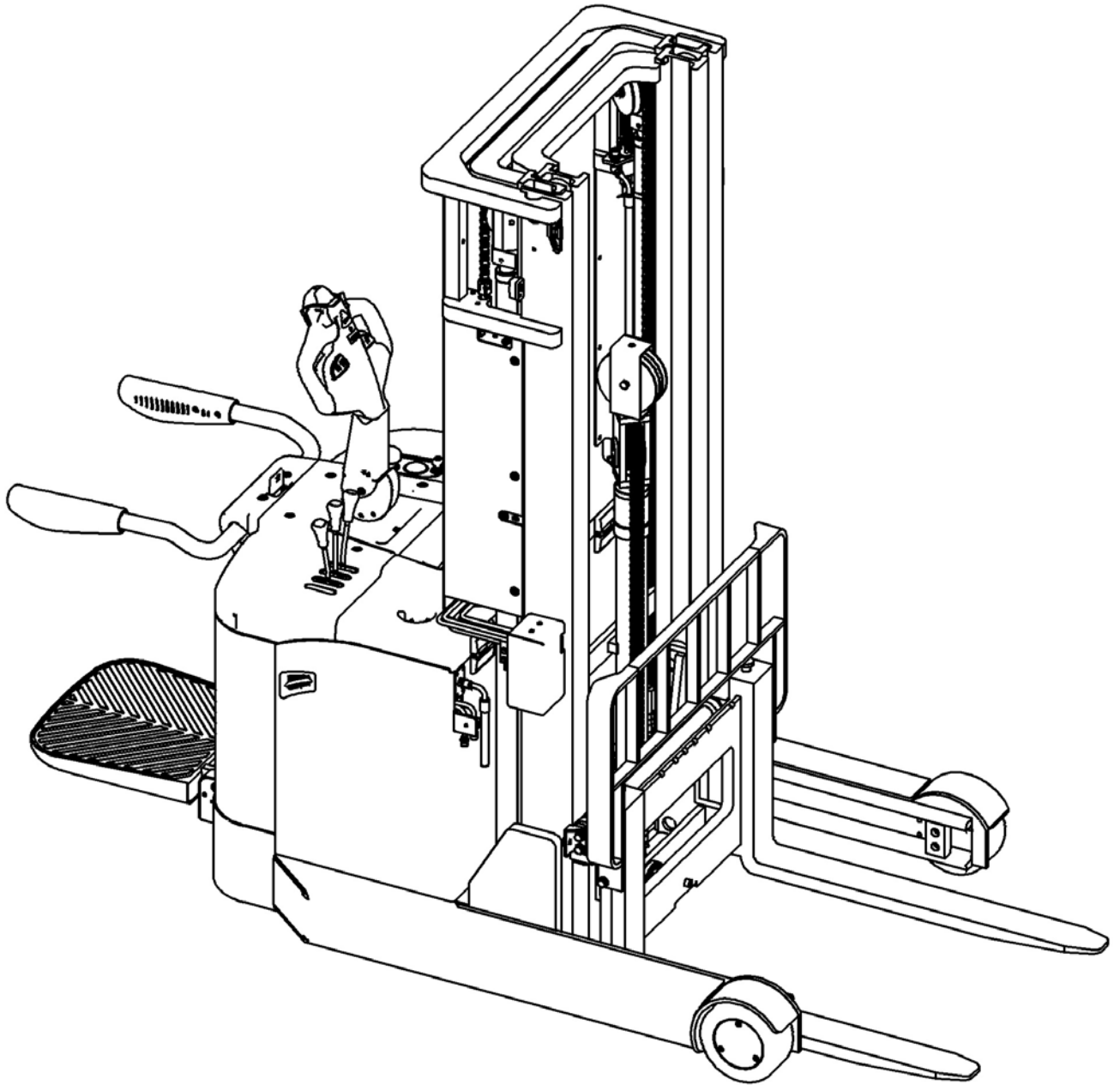
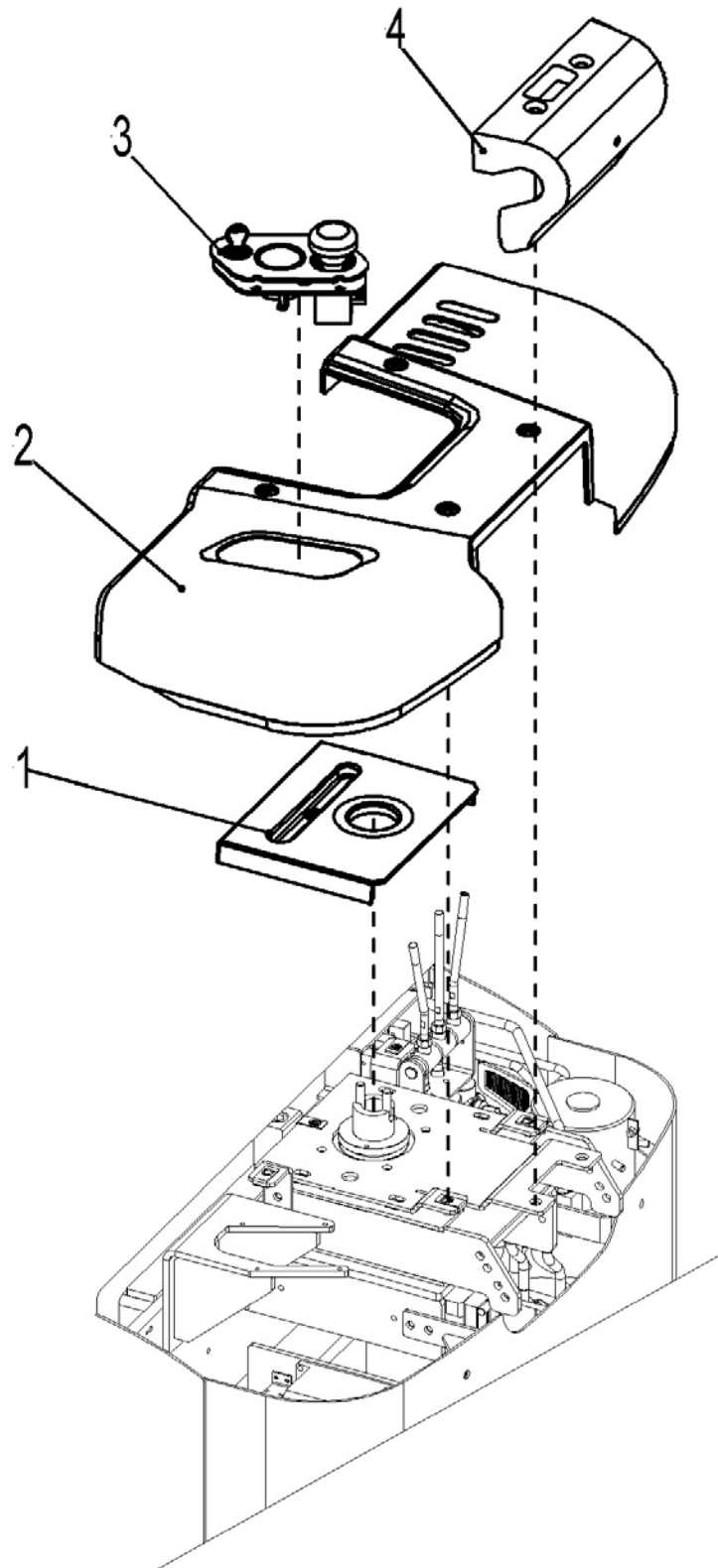

Fig. 6 Control panel



**Fig. 6 Control Panel**

No.	Art No.	Description	Qty.	Note
1	206021520034	Protective cover(middle)	1	
2	201021520036	Protective cover(top)	1	
3	505610001000	Instrument kits	1	
4	505621520025	Protective cover(protective arm)	1	

Fig. 7 Indicator assembly

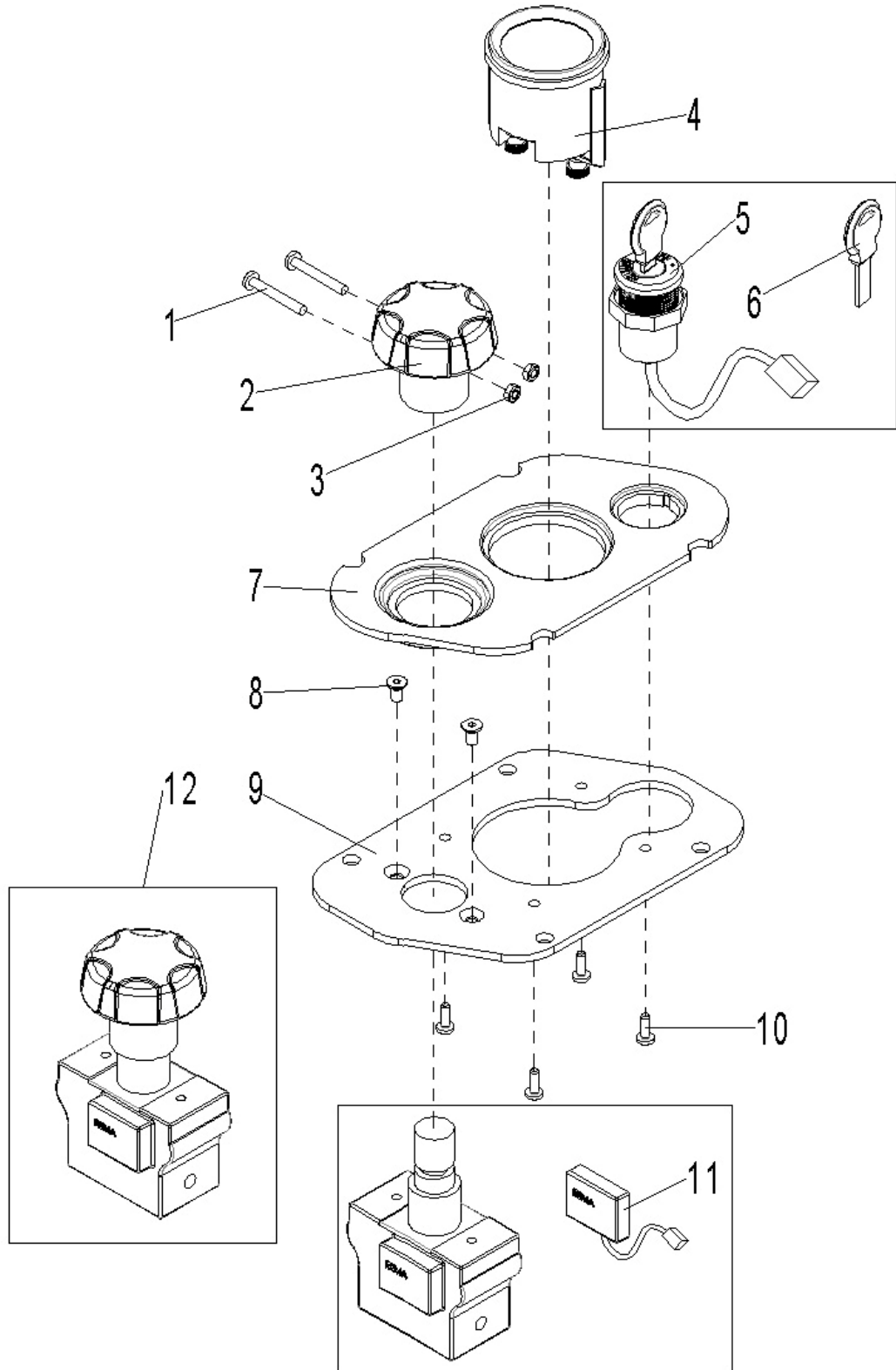

**Fig. 7 Indicator Assembly**

No.	Art No.	Description	Qty.	Note
1	910200500016	Screw	2	M3×25
2	505698520029	Emergency stop button	1	
3	910300100002	Nut	2	M3
4	921100100001	Indicator	1	MDI CAN
5	505634010000	Key switch	1	
6	505698520031	Key	1	
7	505610020000	Plastic board	1	
8	910200400010	Screw	2	M5×10
9	505610020001	Fixing board	1	
10	910201300001	Screw	4	M4×12
11	505698520030	Proximity switch	1	
12	920200100001	DC power switch	1	

Fig. 8 Electrical steering assembly

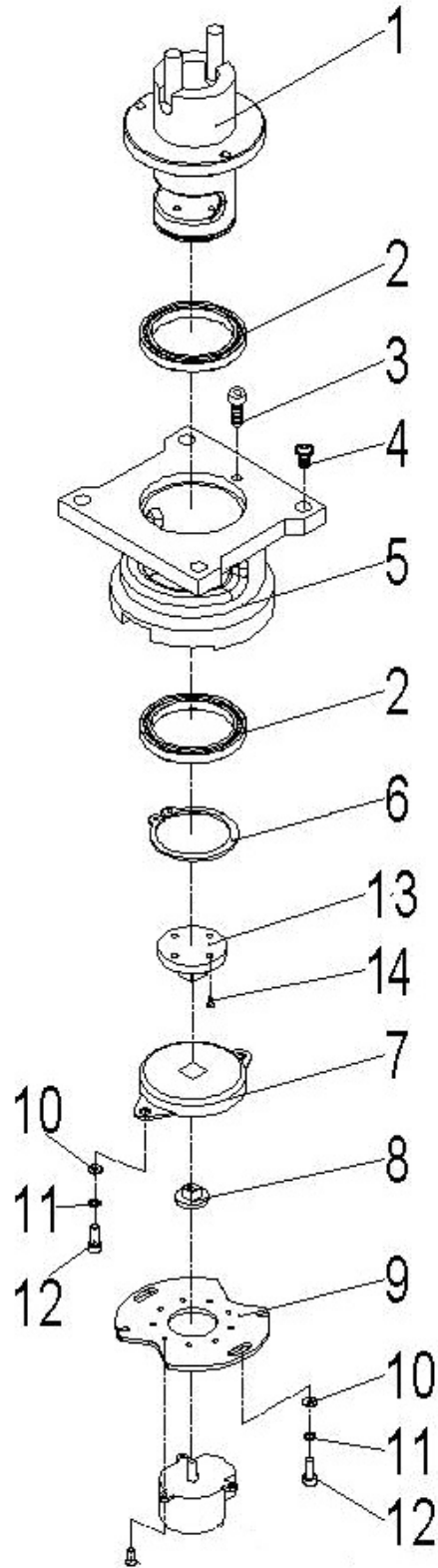
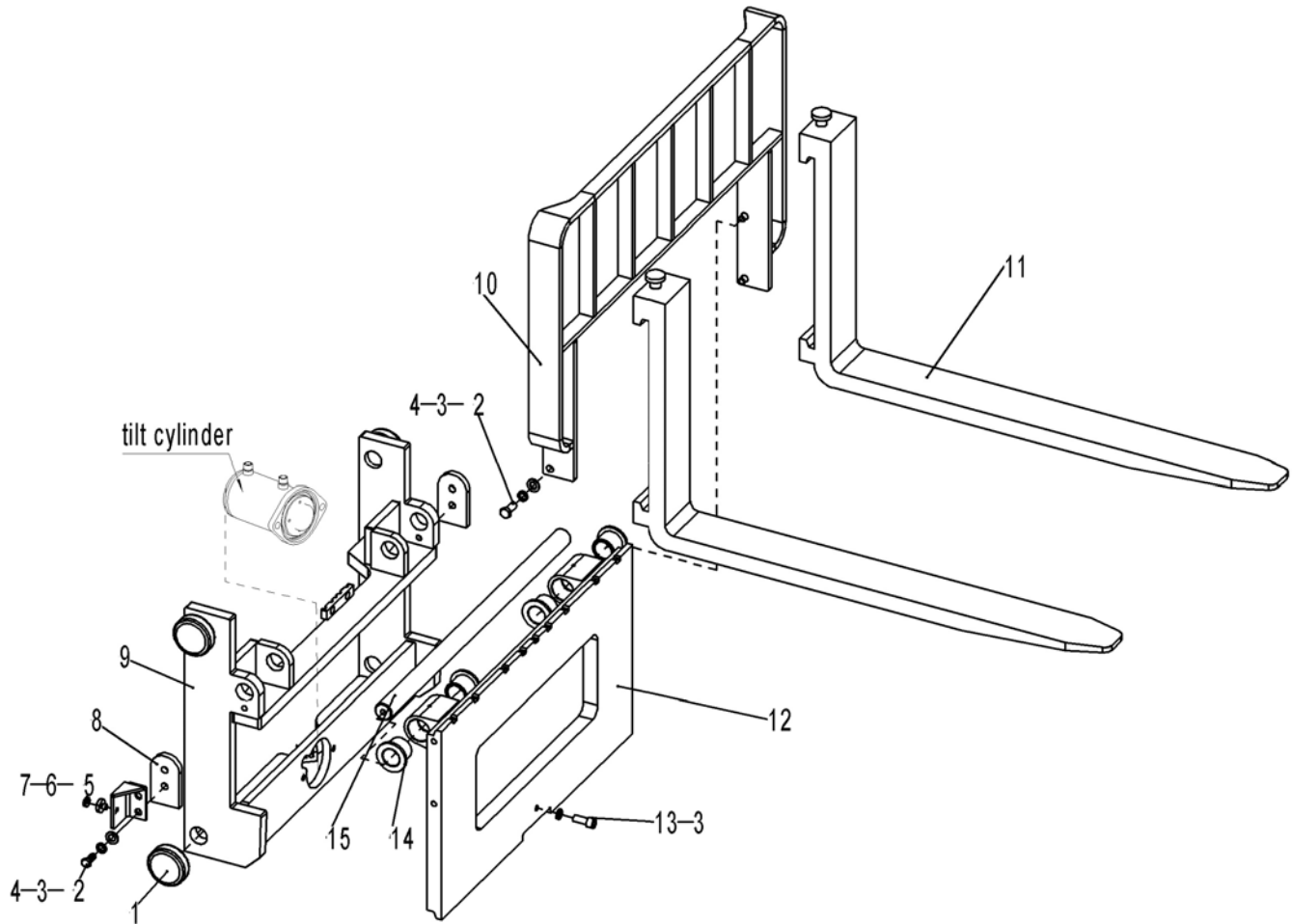

**Fig. 8 Electrical Steering Assembly**

No.	Art No.	Description	Qty.	Note
1	505631510001	Axle seat	1	
2	910700200041	Bearing	2	61810
3	910200200032	Screw	3	M6×10
4	910200200075	Screw	4	M10×20
5	505631520002	Fixing seat	1	
6	910401300024	Circlip	1	50
7	940801200001	Damper	1	
8	505931520002	Transitional linking block	1	
9	505931520001	Potentiometer fixing plate	1	
10	910400100004	Washer	4	5
11	910400500004	Washer	4	5
12	910200200021	Screw	4	M5×10
13	505631520005	Linking block	1	
14	910200200013	Screw	4	M4×10



**Fig. 9 Fork frame kits (single mast)**



**Fig. 9 Fork Frame Kits (single mast)**

No.	Art No.	Description	Qty.	Note
1	940200300012	Compound roller	4	NL077.7.00-00 110-range=50-55
2	910100300050	Bolt	4	GB5783-M12x30-8.8
3	910400500008	Spring washer	5	GB93-12
4	910400100008	Flat washer	4	GB97.1-12-200HV
5	201538020021	Fixing plate (magnetic steel )	1	
6	940600100001	Magnetic steel	1	18x5
7	940600200001	Magnetic steel seat	1	18x16
8	201038020010	Baffle	2	
9	201538010004	Inner carriage welding	1	
10	216540510000	Load backrest welding	1	
11	940100100002	Fork	2	
12	201538010005	Fork frame welding	1	
13	910200200098	Screw	1	GB70.1-M12x30-8.8
14	940500400002	Bearing	4	35x45x40
15	201538020020	Axle 35x714	1	

**Fig. 10 Fork frame kits (two-stage-mast)**

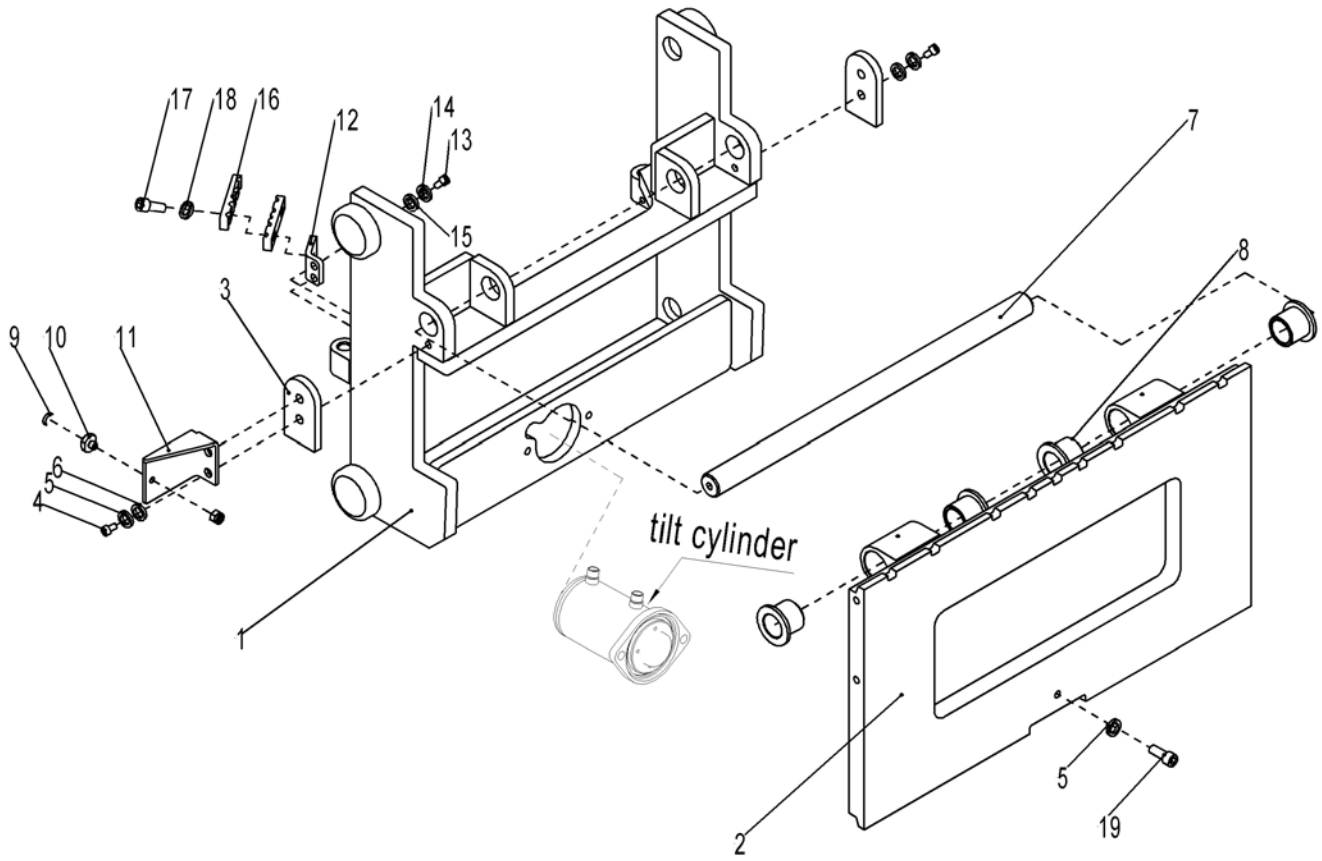

**Fig. 10 Fork Frame Kits (two-stage-mast)**

No.	Art No.	Description	Qty.	Note
1	201538010002	Inner carriage welding	1	
2	201538010003	Fork frame welding	1	
3	201038020010	Baffle	2	
4	910100300050	Bolt	4	GB5783-M12X30-8.8
5	910400500008	Spring washer	5	GB93-12
6	910400100008	Flat washer	4	GB97.1-12-200HV
7	201038020030	Axle	1	35X620
8	940500400002	Bearing	4	35X45X40
9	201538020010	Fixing plate (magnetic steel)	1	
10	940600100001	Magnetic steel	1	18X5
11	940600200001	Magnetic steel seat	1	18X16
12	201044520063	Assembly plate 4 (pipe clamp)	1	
13	910200200075	Screw	2	GB70.1-M10X20-8.8
14	910400500007	Spring washer	2	GB93-10
15	910400100007	Flat washer	2	GB97.1-10-200HV
16	201044520027	Pipe clamp	2	2X10
17	910200200058	Screw	2	GB70.1-M8X25-8.8

**Fig. 10 Fork frame kits (two-stage-mast)**

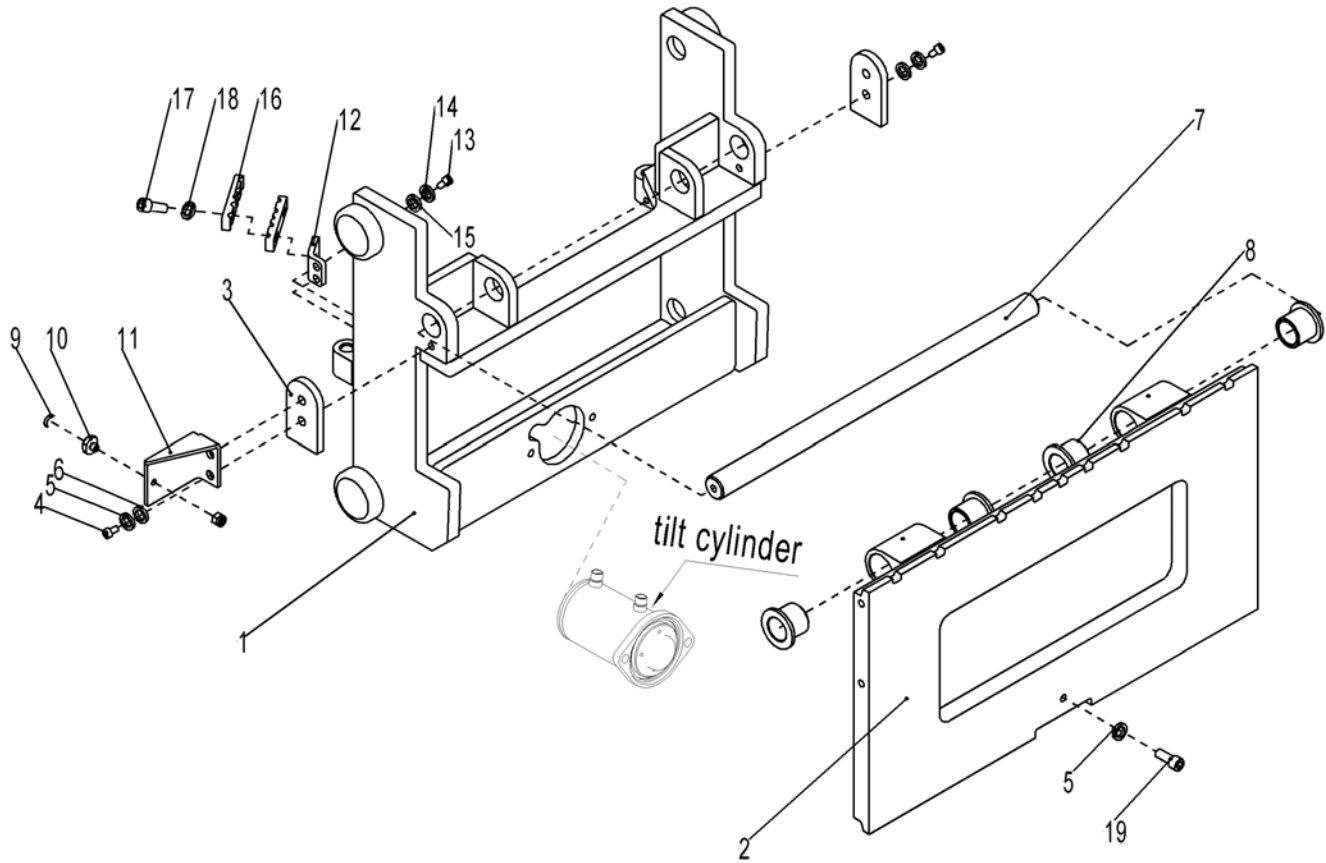

**Fig. 10 Fork Frame Kits (two-stage-mast)**

18	910400500006	Spring washer	2	GB93-8
19	910200200098	Screw	1	GB70.1-M12X30-8.8

Fig. 11 Fork frame kits (three-stage-mast)

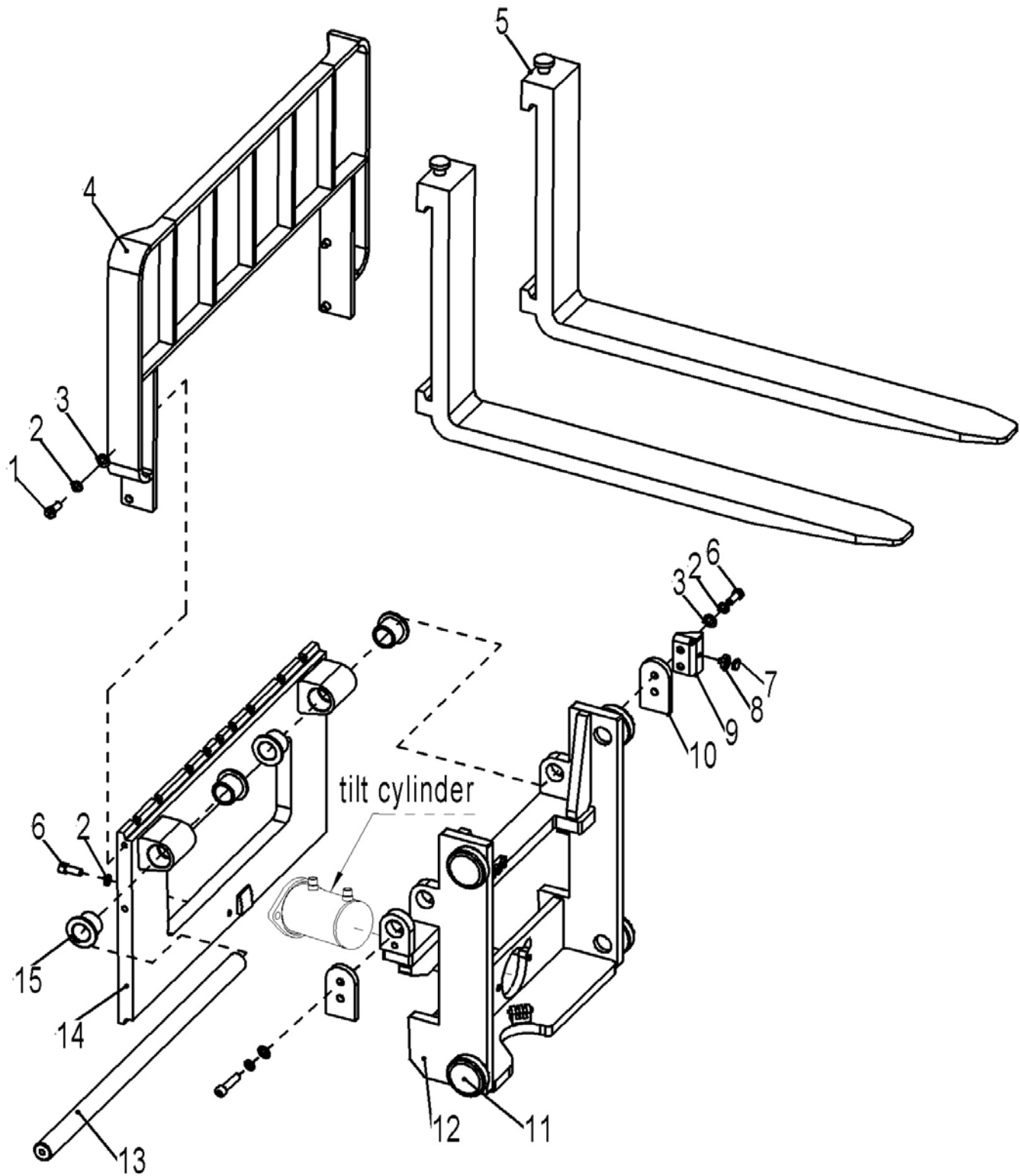
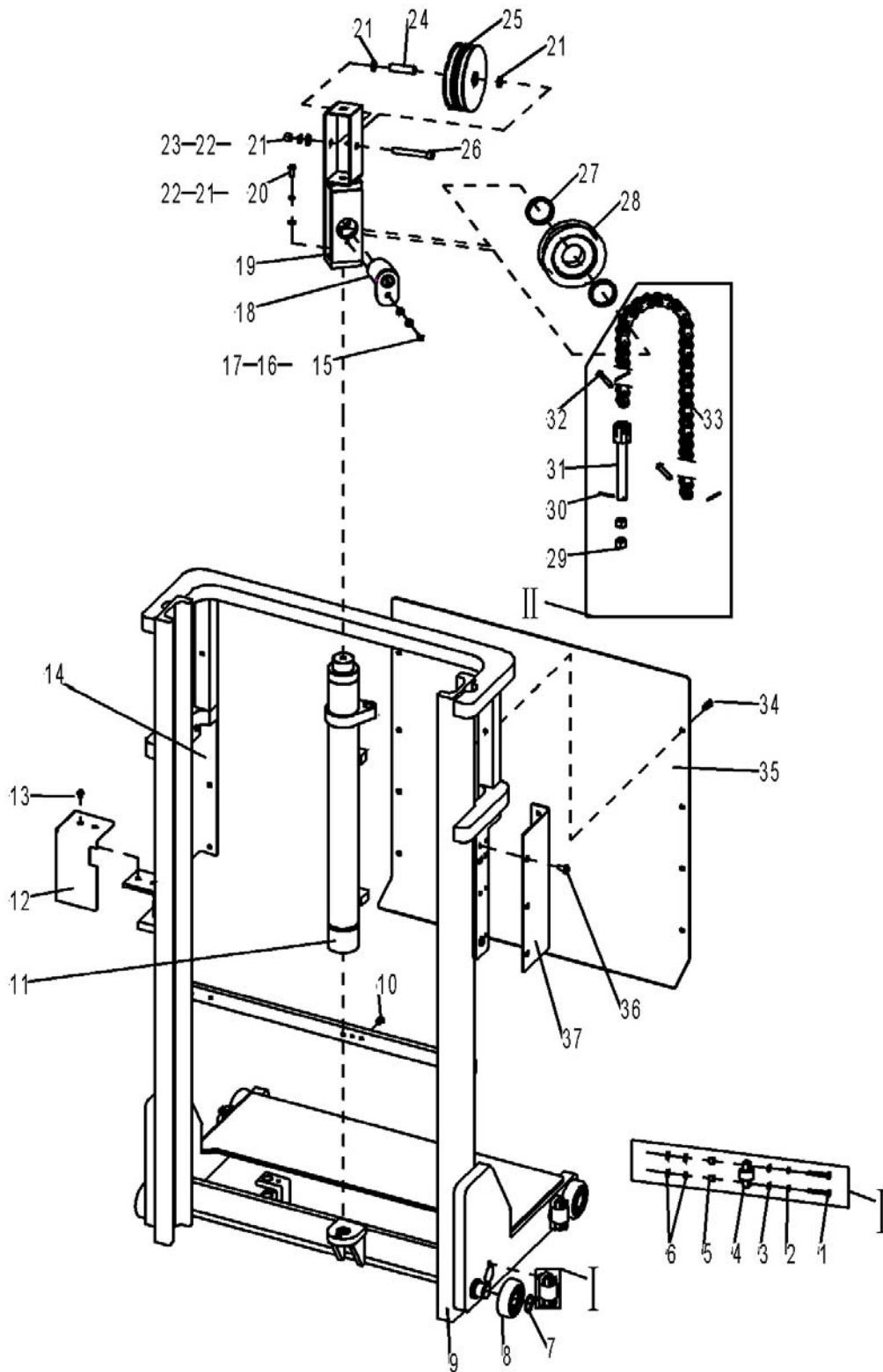

**Fig. 11 Fork Frame Kits (three-stage-mast)**

No.	Art No.	Description	Qty.	Note
1	910200200098	Screw	1	GB70.1-M12x30-8.8
2	910400500008	Spring washer	9	GB93-12
3	910400100008	Flat washer	8	GB97.1-12-200HV
4	216540510000	Load backrest welding	1	
5	940100100002	Fork	2	
6	910200200100	Screw	4	GB70.1-M12x40-8.8
7	940600100001	Magnetic steel 18x5	1	
8	940600200001	Magnetic steel seat 18x16	1	
9	201038020011	Fixing plate (magnetic steel )	1	
10	201038020010	Baffle	2	
11	940200300012	Compound roller	4	NL077.7.00-00 110-range=50-55
12	201538010000	Inner carriage welding	1	
13	201538020000	Axle 35x765	1	
14	201538010001	Fork frame welding	1	(three stage full free mast)
15	940500400002	Bearing	4	35x45x40



Fig. 12 Outer mast kits (single mast)



**Fig. 12 Outer Mast Kits (single mast)**

No.	Art No.	Description	Qty.	Note
1	910200200079	Screw	8	GB70.1-M10x40-8.8
2	910400500007	Spring washer	8	GB93-10
3	910400100007	Flat washer	8	GB97.1-10-200HV
4	940200200007	Side roller	4	42-CD=60
5	940600599004	Washer DIN988-16x8 collective diagram	1	
6	213044502068	Adjusting washer (side roller) collective diagram	1	
7	910401300018	Circlip	4	GB894.1-35
8	940200100006	Main roller	4	92.5x35x28
9	201543010000	Outer mast welding	1	1200
	201543010001	Outer mast welding	1	1600
	201543010002	Outer mast welding	1	1800
10	910200400025	Screw	2	GB70.3-M8x20-8.8
11	201544510013	Cylinder (M)	1	4800/1600
	201544510014	Cylinder (M)	1	4500
	201544510015	Cylinder (M)	1	3600/1200
	201544510016	Cylinder (M)	1	1800
12	201044520024	Protective cover	1	
13	910200300023	Screw	2	GB70.2-M8x12-8.8

Fig. 12 Outer mast kits (single mast)

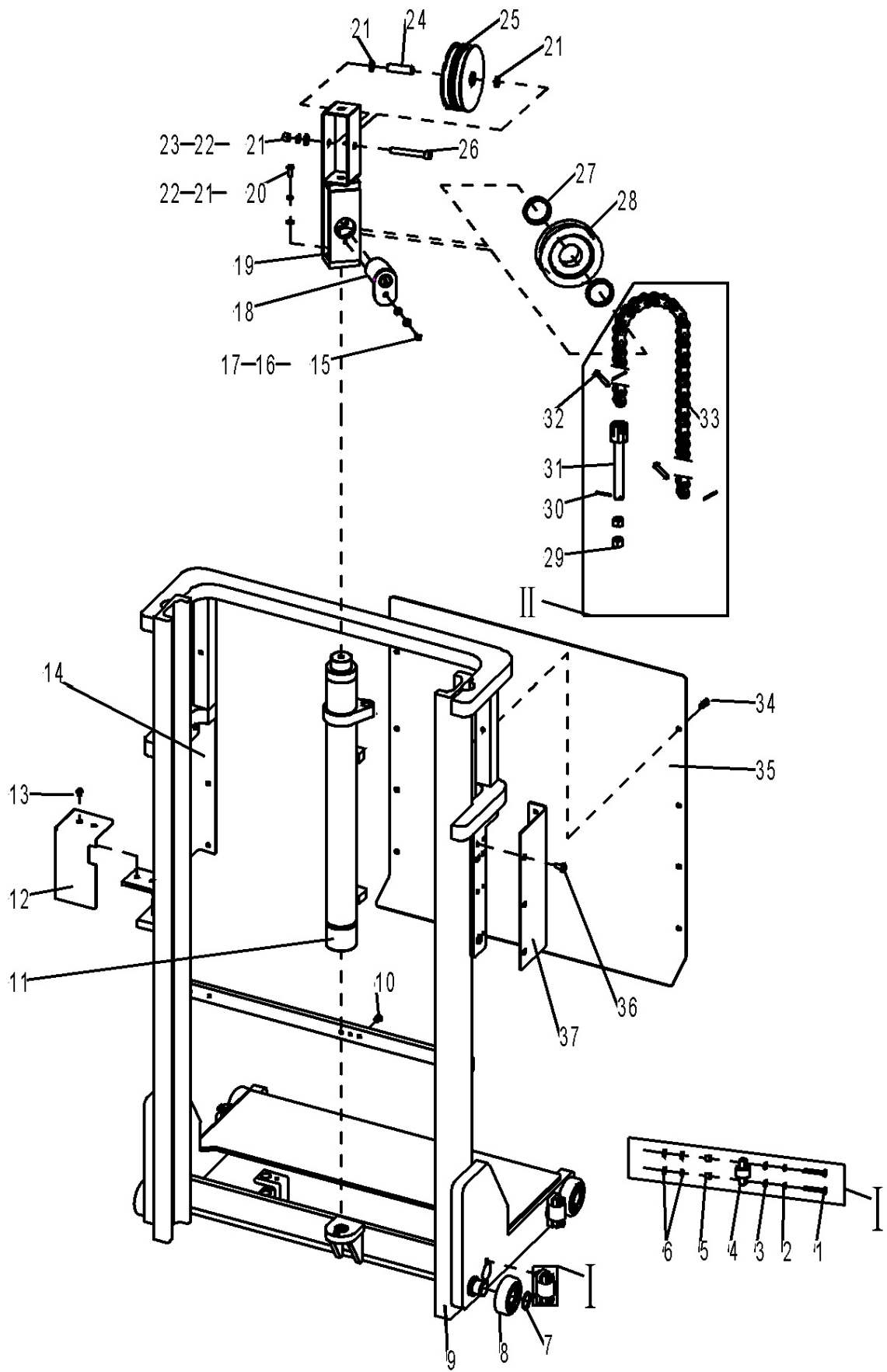

**Fig. 12 Outer Mast Kits (single mast)**

No.	Art No.	Description	Qty.	Note
14	201543020010	Assembly frame 2	1	1200
	201543020011	Assembly frame 2	1	1600
	201543020012	Assembly frame 2	1	1800
15	910400500006	Spring washer	8	GB93-8
16	910400100006	Flat washer	1	GB97.1-8-200HV
17	910200200058	Screw	8	GB70.1-M8x25-8.8
18	201044510000	Axle with plate	1	40x76
19	201044510001	Chain wheel welding	1	
20	910100300050	Bolt		GB5783-M12x30-8.8
21	910400100008	Flat washer	2	GB97.1-12-200HV
22	910400500008	Spring washer	23	GB93-12
23	910300100008	Nut	1	GB6170-M12-10
24	201044520053	Bushing	1	17x13x62
25	213044520165	Pulley		145x60
26	910100100056	Bolt	1	GB5782-M12x90-8.8
27	201044520056	Spacer	2	54x42x10
28	940200500007	Chain wheel bearing	1	HC235ZB-43501100x 40x31.3
29	910300200005	Nut	2	GB6171-M20x1.5-10

Fig. 12 Outer mast kits (single mast)

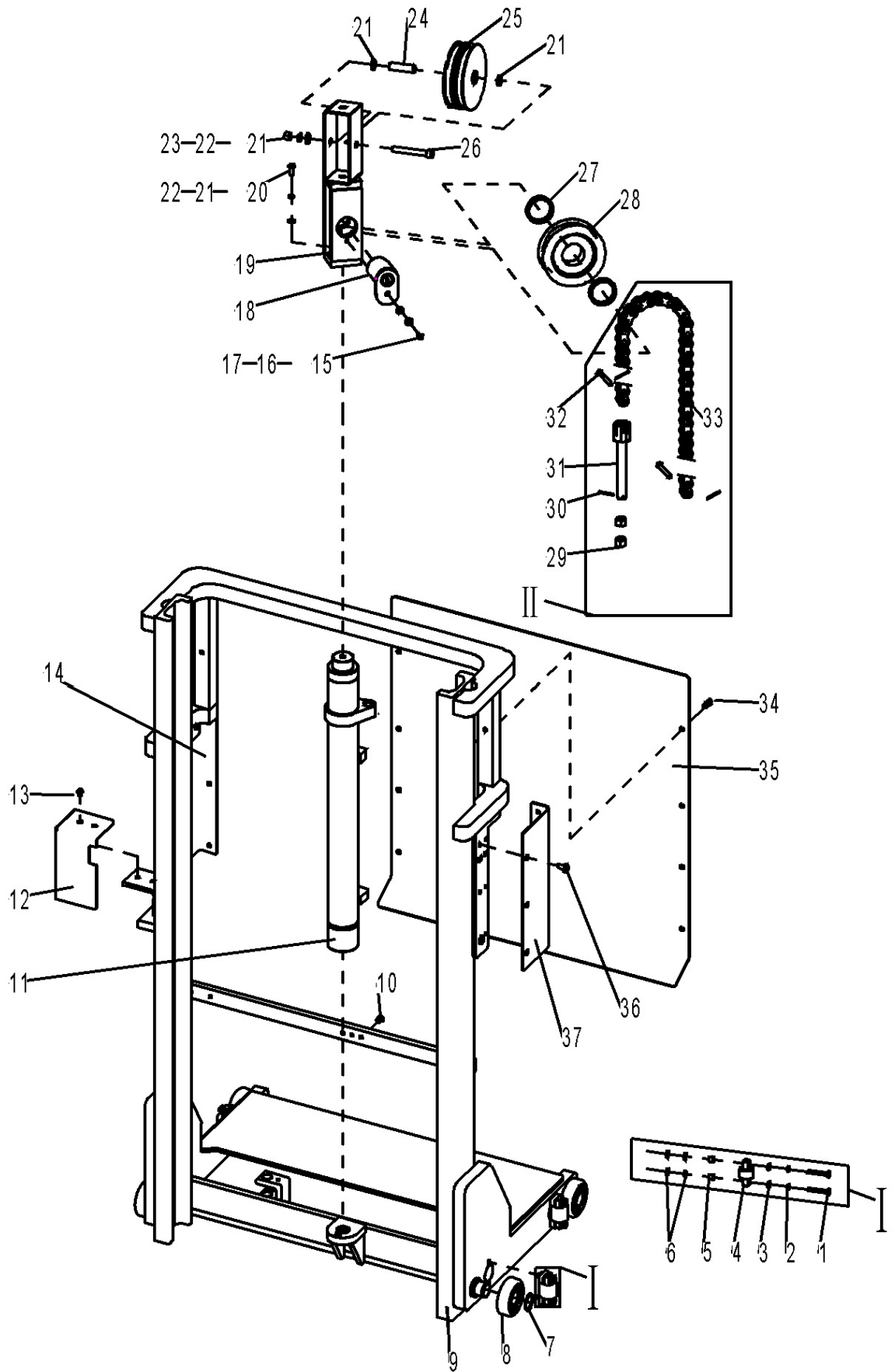

**Fig. 12 Outer Mast Kits (single mast)**

No.	Art No.	Description	Qty.	Note
30	910600600030	Split pin	2	GB91-3.2x30
31	532644020096	Chain bolt	1	M16x1.5x111
32	213044520006	Axle	2	8x45
33	201043010006	Chain LH1244-79	1	
	201044510016	Chain LH1244-77	1	
	201044510018	Chain LH1244-67	1	
34	940800700001	Nylon rivet	10	SR-578
35	201544520002	Protective plate	1	4800/1600
	201544520018	Protective plate	1	3600/2400/1200
	201544520006	Protective plate	1	1800
36	910200300028	Screw	6	GB70.2-M10x20-8.8
37	201543020007	Assembly frame1	1	1200
	201543020008	Assembly frame1	1	1600
	201543020009	Assembly frame1	1	1800
I	213098510003	side roller kits	4	
II	213044502006	Middle lifting chain collective diagram	1	

Fig. 13 Outer mast kits (two and three stage mast)

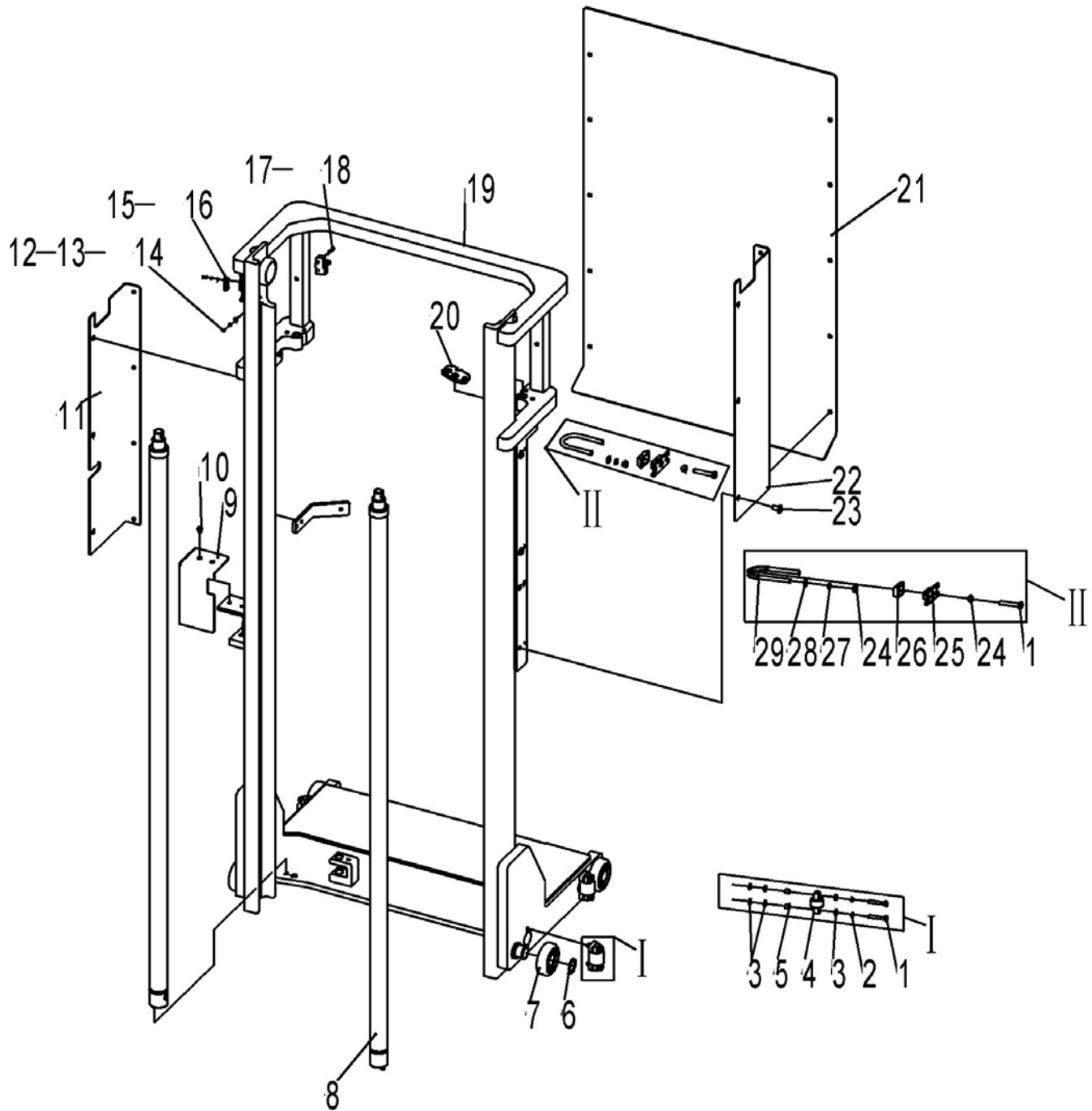
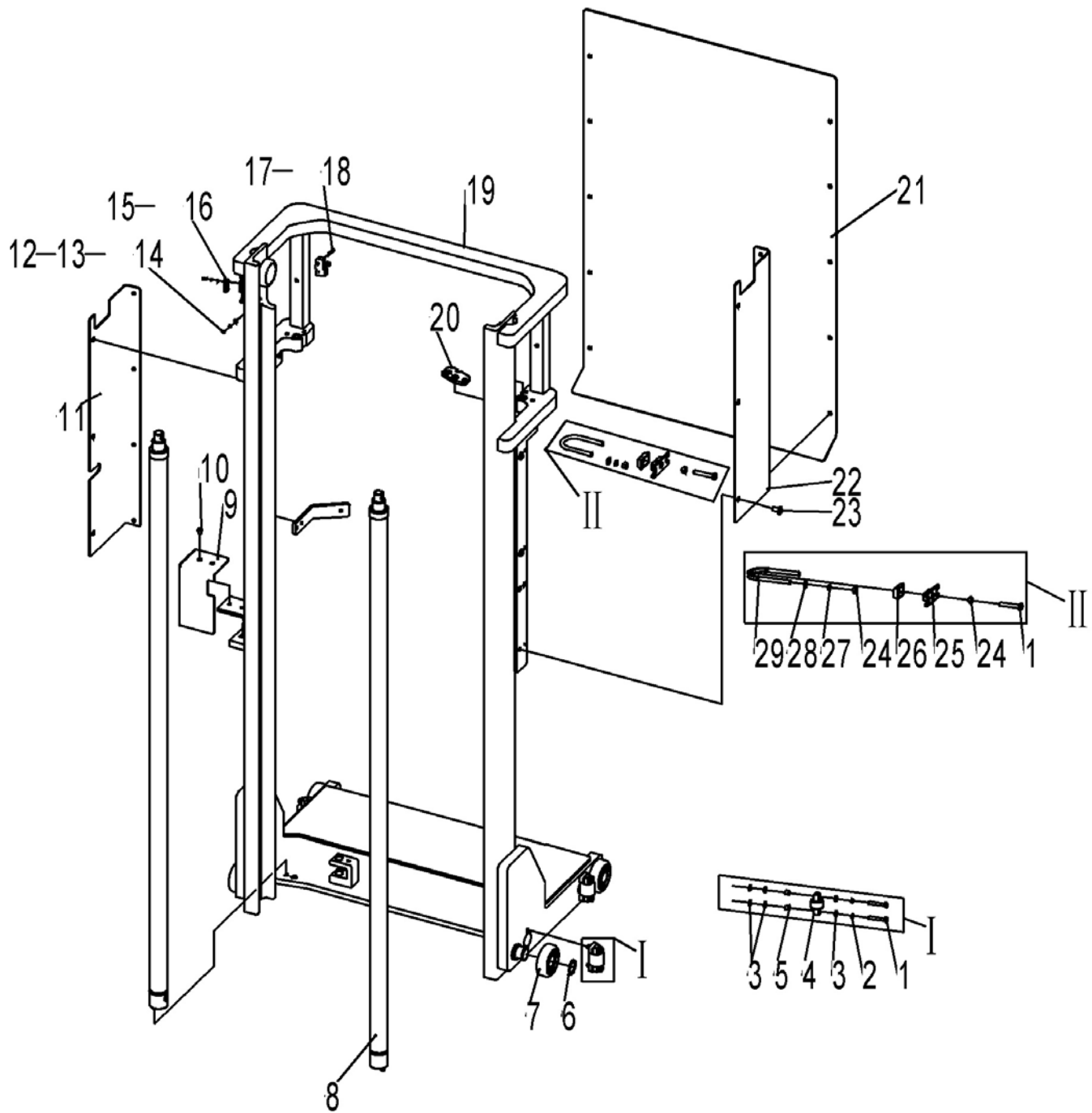

**Fig. 13 Outer Mast Kits (two and three stage mast)**

No.	Art No.	Description	Qty.	Note
1	910200200079	Screw	10	GB70.1-M10x40-8.8
2	910400500007	Spring washer	12	GB93-10
3	910400100007	Flat washer	12	GB97.1-10-200HV
4	940200200007	Side roller	4	42-CD=60
5	213044502068	Adjusting washer (side roller) collective	1	
6	910401300018	Circlip	4	GB894.1-35
7	940200100006	Main roller	4	92.5x35x28
8	201544510010	Lifting cylinder	1	4800
	201544510011	Lifting cylinder	1	4500/3000
	201544510012	Lifting cylinder	1	3600/2400
9	201044520024	Protective cover (oil hose)	1	
10	910200300023	Screw	2	GB70.2-M8x12-8.8
11	201544520001	Assembly frame 2	1	4800
	201544520020	Assembly frame 2	1	4500/3000
	201544520021	Assembly frame 2	1	3600/2400
12	910300500001	Nut	1	GB889.1-M4-10
13	910400500003	Spring washer	1	GB93-4
14	910400100003	Flat washer	1	GB97.1-4-200HV



Fig. 13 Outer mast kits (two and three stage mast)



**Fig. 13 Outer Mast Kits (two and three stage mast)**

No.	Art No.	Description	Qty.	Note
15	910200300003	Screw	1	GB70.2-M3x10-8.8
16	920200500001	Magnetic switch	1	HWK23
17	910200500028	Screw	1	GB818-M4x30-4.8
18	920200300001	Micro switch	1	XZ-15GW22-B
19	201544510000	Outer mast welding	1	4800
	201544510001	Outer mast welding	1	4500
	201544510002	Outer mast welding	1	3600
20	201044520029	Assembly plate	1	
21	201544520002	Protective plate	1	4800/1600
	201544520017	Protective plate	1	4500/3000
	201544520018	Protective plate	1	3600/2400/1200
22	201544520000	Assembly frame 1	1	4800
	201544520018	Assembly frame 1	1	4500/3000
	201544520019	Assembly frame 1	1	3600/2400
23	940800700001	Nylon rivet	10	SR-578
24	910300100007	Nut	6	GB6170-M10-10
25	255044020130	Fixing seat (cylinder)	2	
26	255044020129	Protective cover	2	

Fig. 13 Outer mast kits (two and three stage mast)

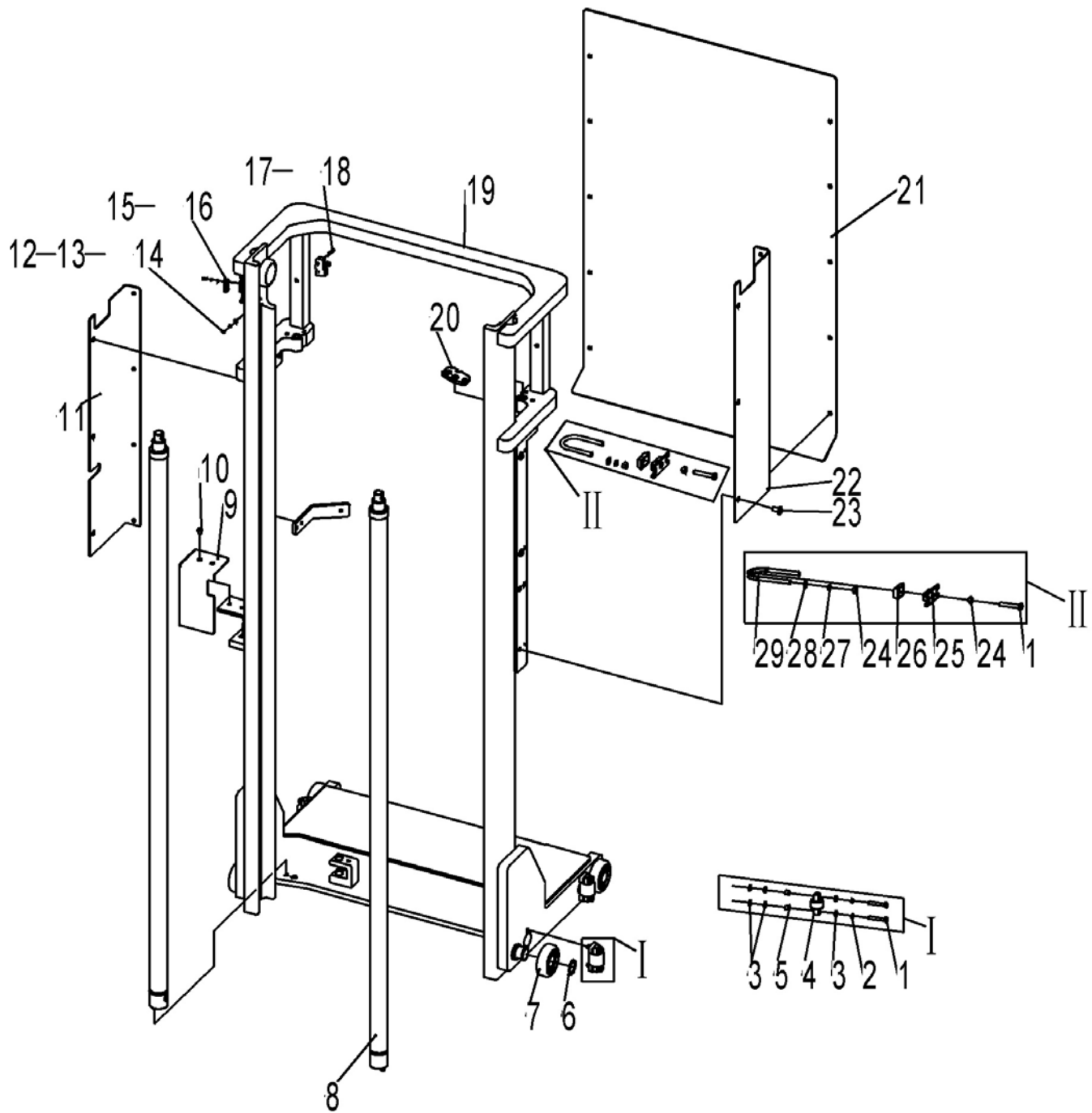

**Fig. 13 Outer Mast Kits (two and three stage mast)**

No.	Art No.	Description	Qty.	Note
27	910400500007	Spring washer	12	
28	910400100007	Flat washer	12	
29	201044520017	Bolt	2	60
I	213098510003	Side roller kits	4	
II	213098510004	Cylinder hoop kits	2	

Fig. 14 Inner mast kits (Two stage mast)

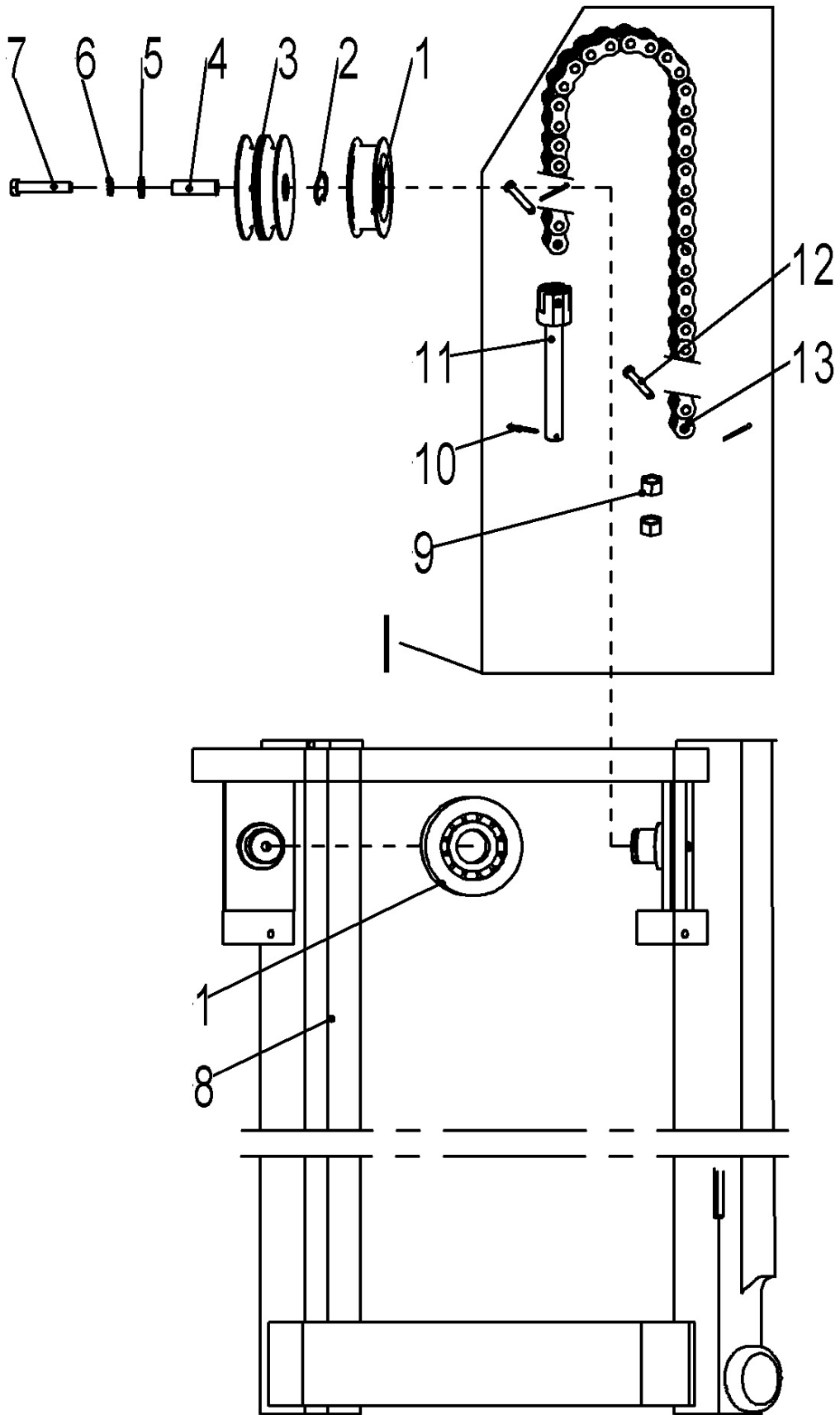

**Fig. 14 Inner Mast Kits (two stage mast)**

No.	Art No.	Description	Qty.	Note
1	940200500001	Chain wheel bearing 780708K-100X40X27	2	
2	910401300020	Circlip GB894.1-40	2	
3	201044520040	Pulley 110X24	2	
4	201044520039	Bushing 17X13X54	1	
5	91040010008	Flat washer GB97.1-12-200HV	2	
6	910400500008	Spring washer GB93-12	2	
7	910100300057	Bolt GB5783-M12X70-8.8	2	
8	201544002000	Middle mast welding	1	
9	910300200008	Nut	2	GB6171-M16x1.5-10
10	910600600030	Split pin	2	GB91-3.2x30
11	533243520008	Chain bolt	1	M16x1.5x111
12	910600700029	Axle	2	GB882-B8x40x2
13	201544510017	Chain LH1234-107	2	4800
	201044510017	Chain LH1234-103	2	4500/3000
	201044510019	Chain LH1234-87	2	3600/2400
I	201544502006	Sideward lifting chain collective diagram	1	

Fig. 15 Middle mast kits (three stage mast)

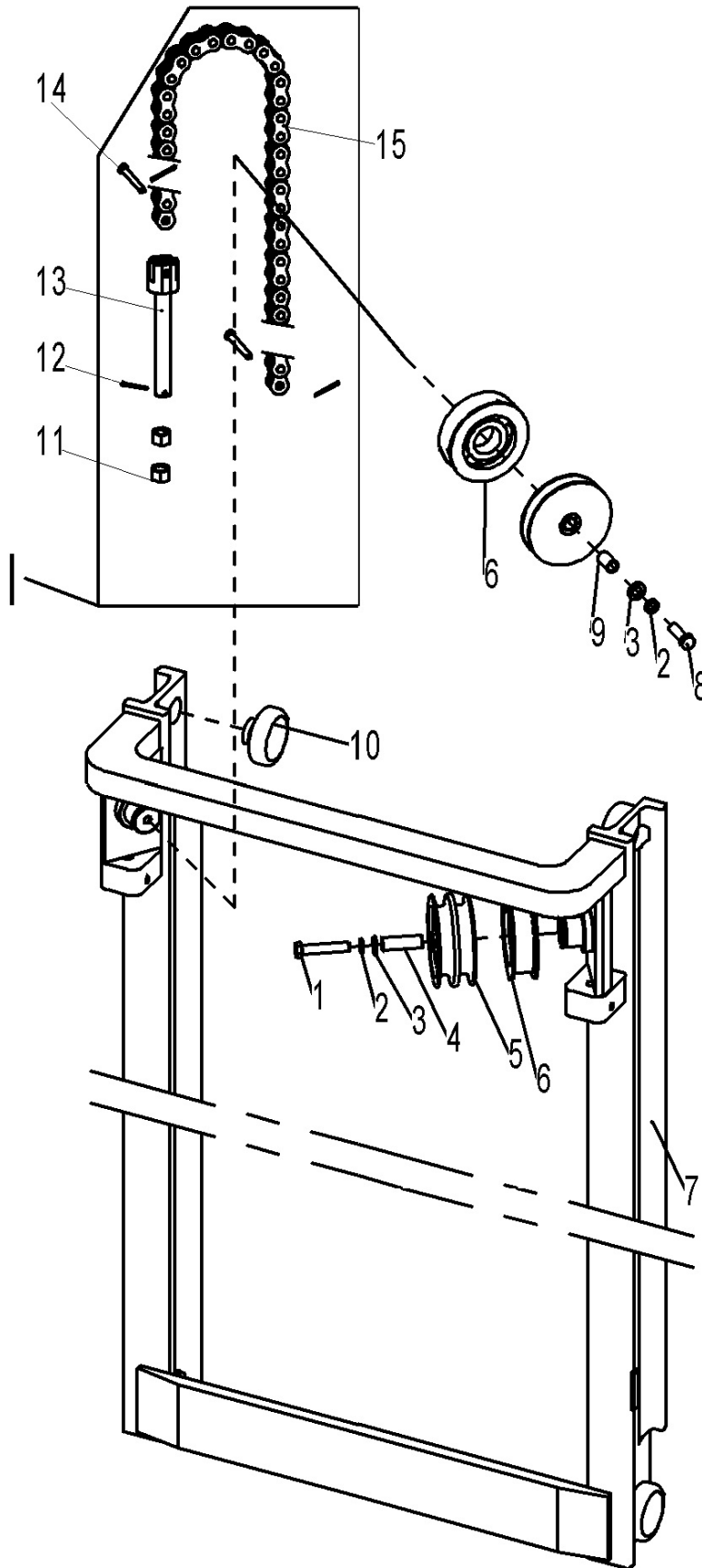
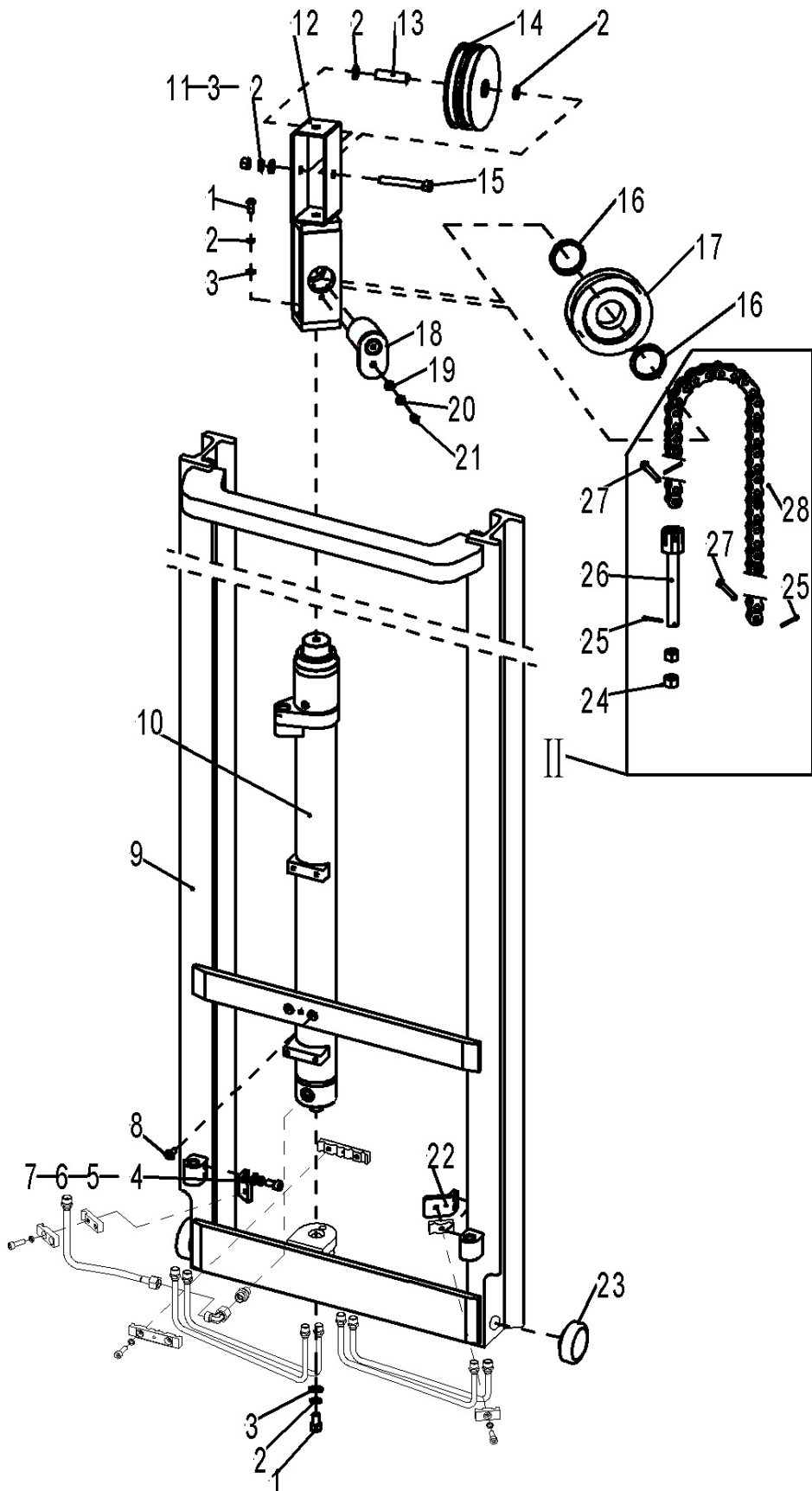

**Fig. 15 Middle Mast Kits (three stage mast)**

No.	Art No.	Description	Qty.	Note
1	910100300057	Bolt	1	GB5783-M12x70-8.8
2	910400500008	Spring washer	2	GB93-12
3	910400100008	Flat washer	2	GB97.1-12-200HV
4	201044520039	Bushing	1	17x13x54
5	201044520040	Pulley	3	110x24
6	940200500001	Chain wheel bearing	2	780708K-100X40X27
7	201544510003	Middle mast welding	1	
	201544510004	Middle mast welding	1	
	201544510005	Middle mast welding	1	
8	910100300052	Bolt	1	GB5783-M12x40-8.8
9	201044520041	Bushing	1	17x13x28
10	940200300012	Compound roller	4	NL077.7.00-00 110-range=50-55
11	910300200008	Nut	2	GB6171-M16x1.5-10
12	910600600030	Split pin	2	GB91-3.2x30
13	533243520008	Chain bolt	1	M16x1.5x111
14	910600700029	Axle	2	GB882-B8x40x2
15	201544510017	Chain LH1234-107	2	4800
	201044510017	Chain LH1234-103	2	4500/3000
	201044510019	Chain LH1234-87	2	3600/2400
I	201544502006	Sideward lifting chain collective diagram	1	



Fig. 16 Inner mast kits (three stage mast)



**Fig. 16 Inner Mast Kits (three stage mast)**

No.	Art No.	Description	Qty.	Note
1	910200200098	Screw	2	GB70.1-M12x30-8.8
2	910400100008	Flat washer GB97.1-12-200HV	5	
3	910400500008	Spring washer	2	GB93-12
4	910200200058	Screw	1	GB70.1-M8x25-8.8
5	910400500006	Spring washer	1	GB93-8
6	910400100006	Flat washer	1	GB97.1-8-200HV
7	201044520060	Assembly plate 3 (Pipe clamp)	1	
8	910200400025	Screw	2	GB70.3-M8x20-8.8
9	201544510006	Inner mast welding	1	
	201544510007	Inner mast welding	1	
	201544510008	Inner mast welding	1	
10	201544510013	Cylinder(M)	1	4800/1600
	201544510014	Cylinder(M)	1	4500
	201544510015	Cylinder(M)	1	3600/1200
	201544510016	Cylinder(M)	1	1800
11	910300100008	Nut	1	GB6170-M12-10
12	201044510001	Chain wheel welding	1	
13	201044520053	Bushing 17x13x62	1	

Fig. 16 Inner mast kits (three stage mast)

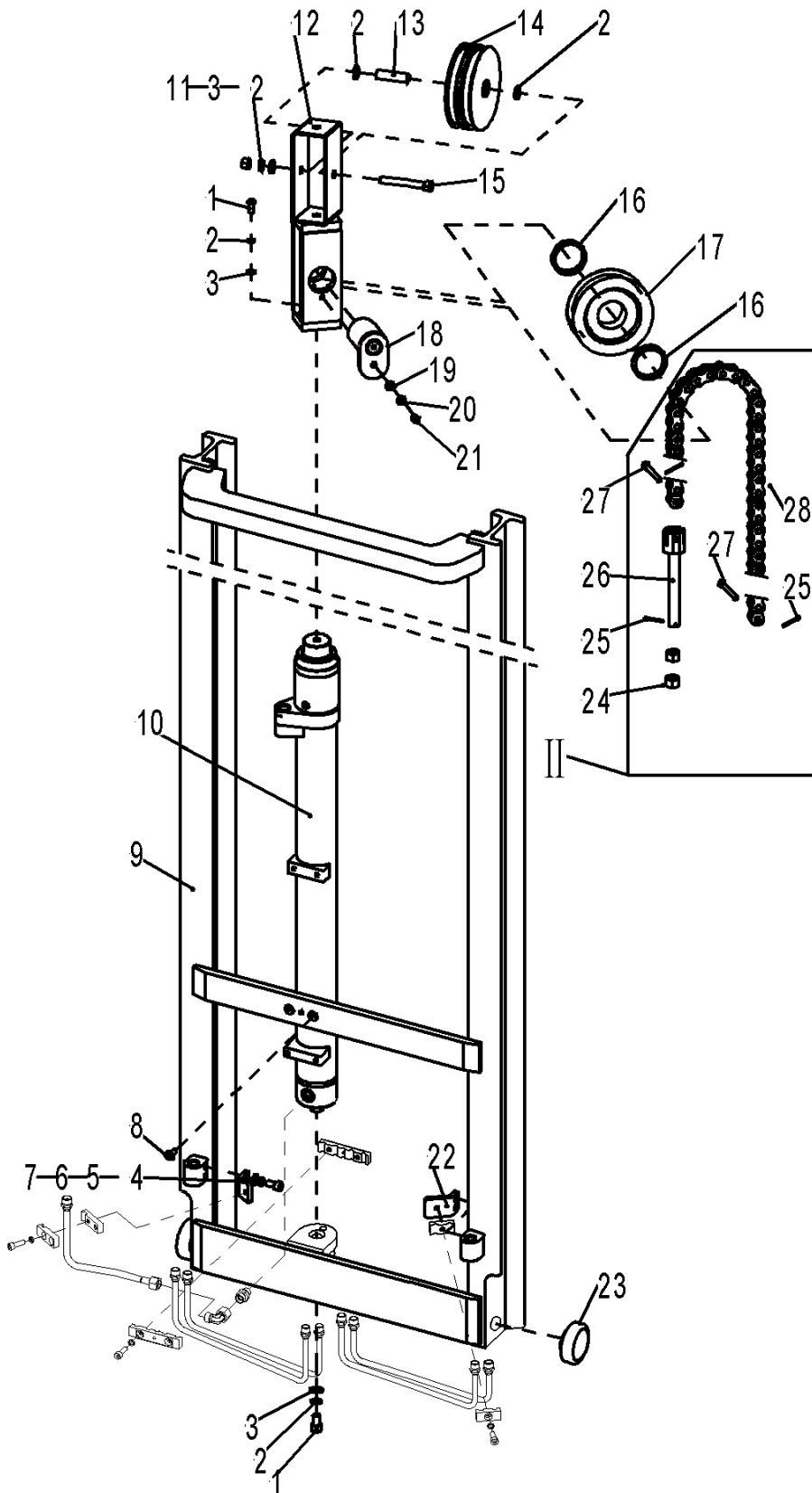

**Fig. 16 Inner Mast Kits (three stage mast)**

No.	Art No.	Description	Qty.	Note
14	213044520165	Pulley 145x60	1	
15	910100100056	Bolt	1	GB5782-M12x90-8.8
16	201044520056	Spacer	2	54x42x10
17	940200500007	Chain wheel bearing	1	100x40x31.3
18	201044510000	Axle with plate 40x76	1	
19	910400100006	Flat washer	1	GB97.1-8-200HV
20	910400500006	Spring washer	5	GB93-8
21	910200200058	Screw	1	GB70.1-M8x25-8.8
22	201044520063	Assembly plate 4 (Pipe clamp)	1	
23	940200300012	Compound roller	2	NL077.7.00-00 110-range=50-55
24	910300200005	Nut	2	GB6171-M20x1.5-10
25	910600600030	Split pin	2	GB91-3.2x30
26	532644020096	Chain bolt	1	M16x1.5x111
27	213044520005	Axle	2	9.5x52
28	201043010006	Chain LH1234-79	1	4800/1800
	201044510016	Chain LH1234-77	1	4500/1600
	201044510018	Chain LH1234-67	1	3600/1200
II	201544502005	Middle lifting chain collective diagram	1	

Fig. 17 Single mast hydraulic pipeline (three ways)

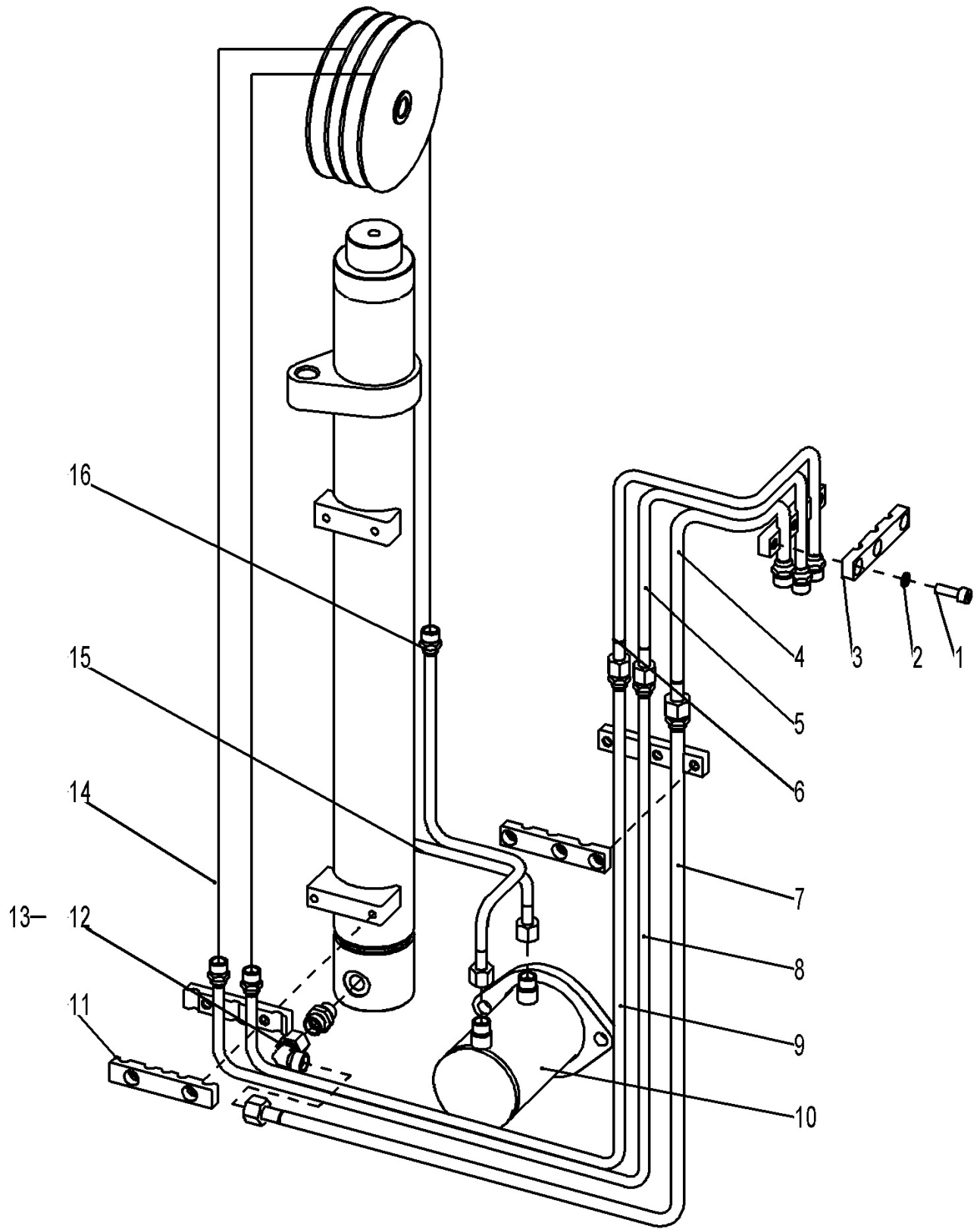

**Fig. 17 Single Mast Hydraulic Pipeline (three ways)**

No.	Art No.	Description	Qty.	Note
1	910200200058	Screw	8	GB70.1-M8x25-8.8
2	910400500006	Spring washer	8	GB93-8
3	201044520022	Pipe clamp	4	2x10-12
4	201043020009	Hydraulic pipe welding 1	1	
5	201043020010	Hydraulic pipe welding 2	1	
6	201043020011	Hydraulic pipe welding 3	1	
7	201543020011	Hydraulic pipe welding 1	1	
8	201543020012	Hydraulic pipe welding 2	1	
9	201543020013	Hydraulic pipe welding 3	1	
10	201020510000	Tilt cylinder kits	1	
11	201044520062	Pipe clamp	2	2x10
12	950400400004	Joint (straight)	1	12-M16x1.5-M18x1.5-2 4°
13	950400200004	Joint (turning)	1	12-2xM18x1.5-24°
14	201043020015	Hydraulic hose assembly (straight)	2	4800/1600
	201044520092	Hydraulic hose assembly (straight)	2	3600/1200
	201043020017	Hydraulic hose assembly (straight)	2	1800
15	201044520073	Hydraulic pipe welding 9	1	
16	201044520074	Hydraulic pipe welding 10	1	

Fig. 18 Single mast hydraulic pipeline (four ways)

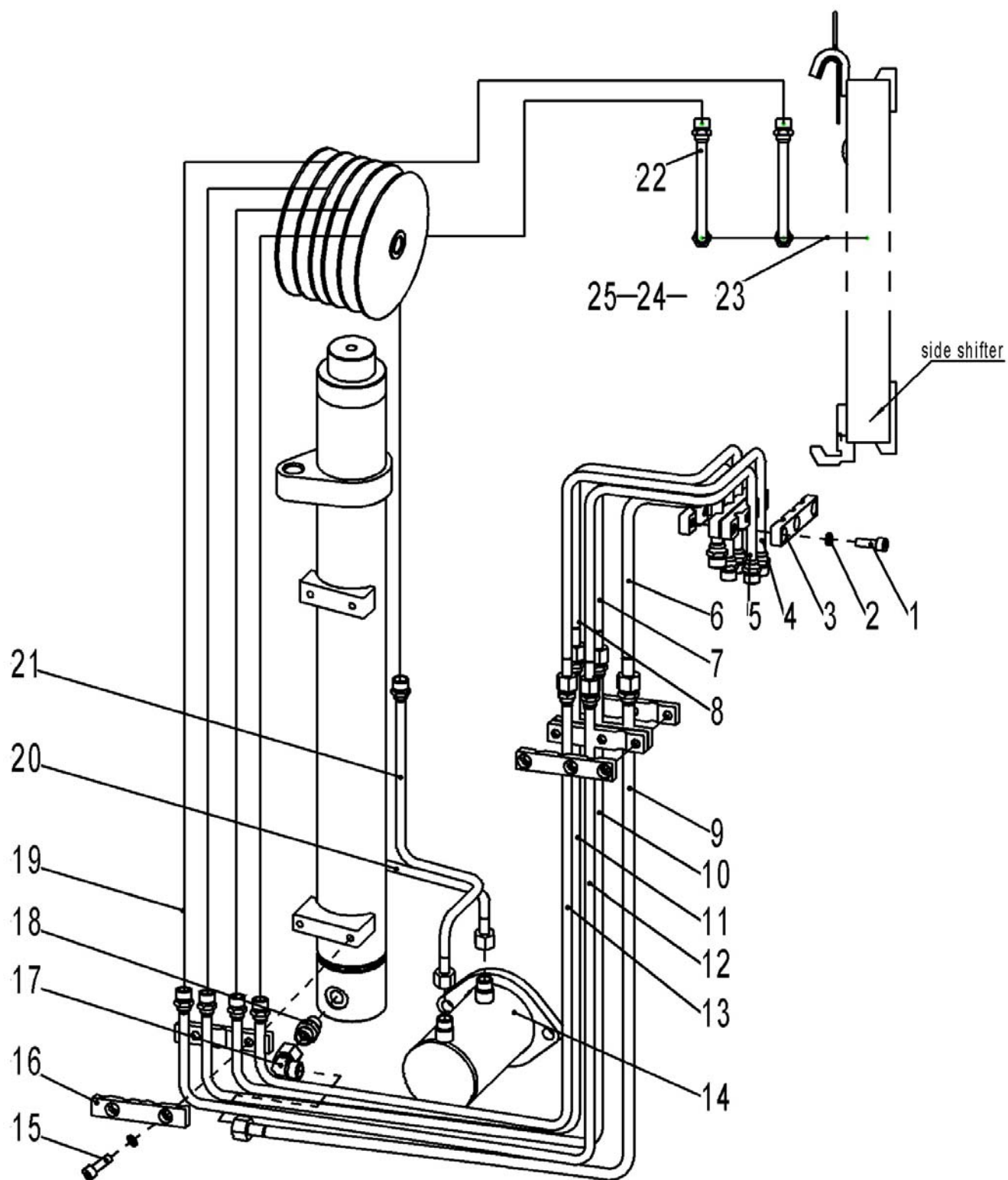
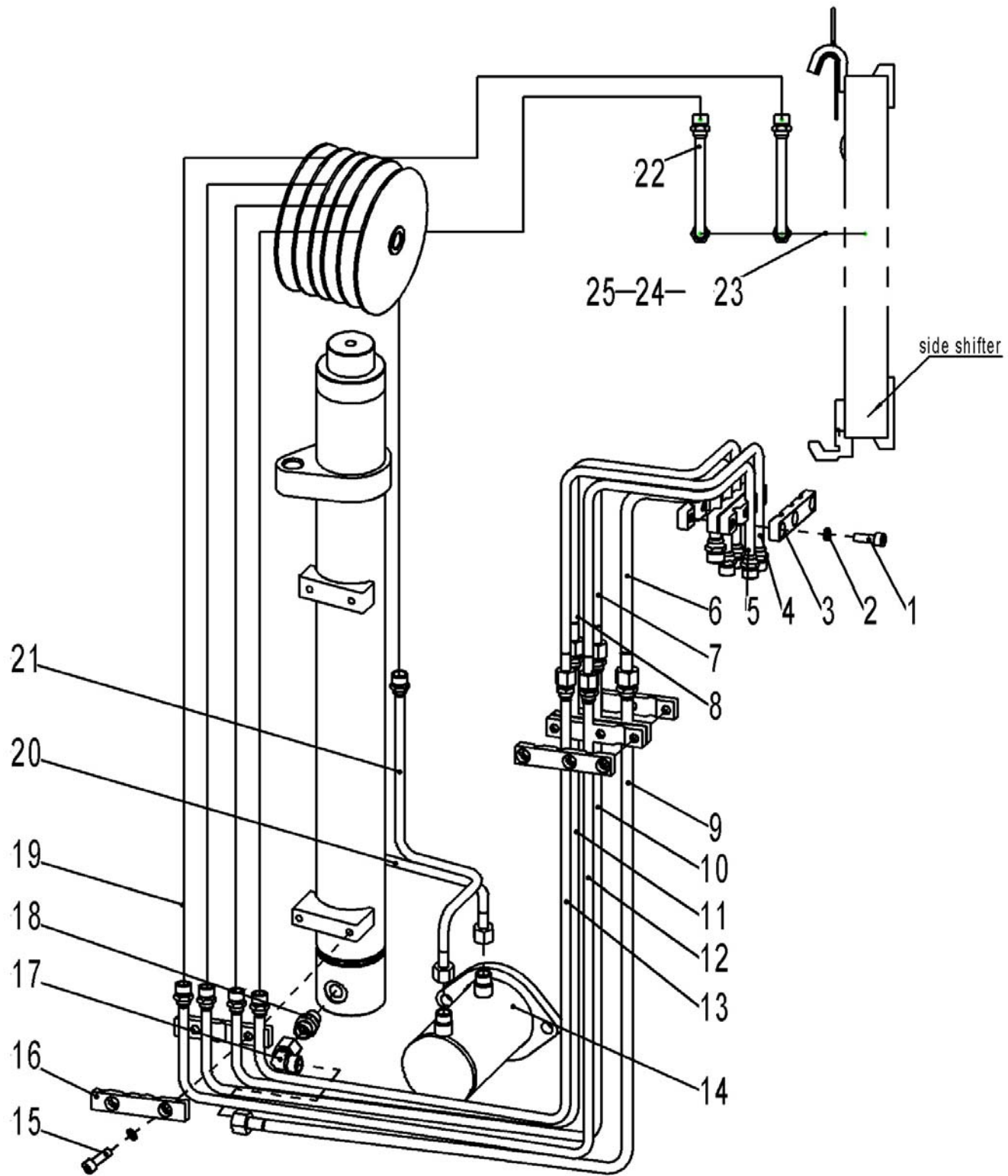

**Fig. 18 Single mast hydraulic pipeline (four ways)**

No.	Art No.	Description	Qty.	Note
1	910200200064	Screw	4	GB70.1-M8x55-8.8
2	910400500006	Spring washer	6	GB93-8
3	201044520022	Clamp	4	2x10-12
4	201527020003	Hydraulic pipe welding 3	1	
5	201527020002	Hydraulic pipe welding 2	1	
6	201043020009	Hydraulic pipe welding 1	1	
7	201043020010	Hydraulic pipe welding 2	1	
8	201043020011	Hydraulic pipe welding 3	1	
9	201543020011	Hydraulic pipe welding 1	1	
10	201543020012	Hydraulic pipe welding 2	1	
11	201543020013	Hydraulic pipe welding 3	1	
12	201527020000	Hydraulic pipe welding 1	1	
13	201527020001	Hydraulic pipe welding 2	1	
14	201020510000	Tilt cylinder components	1	
15	910200200058	Screw	2	GB70.1-M8x25-8.8
16	201044520062	Clamp	2	2x10
17	950400400004	Joint (straight)	1	12-M16x1.5-M18x1.5-2 4°
18	950400200004	Joint (turning)	1	12-2xM18x1.5-24°



Fig. 18 Single mast hydraulic pipeline (four ways)



**Fig. 18 Single mast hydraulic pipeline (four ways)**

No.	Art No.	Description	Qty.	Note
19	201043020015	Hydraulic hose assembly(straight)	4	4800/1600
	201044520092	Hydraulic hose assembly(straight)	4	3600/1200
	201043020017	Hydraulic hose assembly(straight)	4	1800
20	201044520073	Hydraulic pipe welding 9	1	
21	201044520074	Hydraulic pipe welding 10	1	
22	201030520012	Hydraulic pipe welding 10	2	
23	201030520013	Hydraulic hose assembly	2	(90°)10-L250-1SC-24 。
24	201030520014	Damping hole	2	0.8
25	950401100003	Joint	2	10-G1/4-M16x1.5-24°

Fig. 19 Two stage mast hydraulic pipeline (three ways)

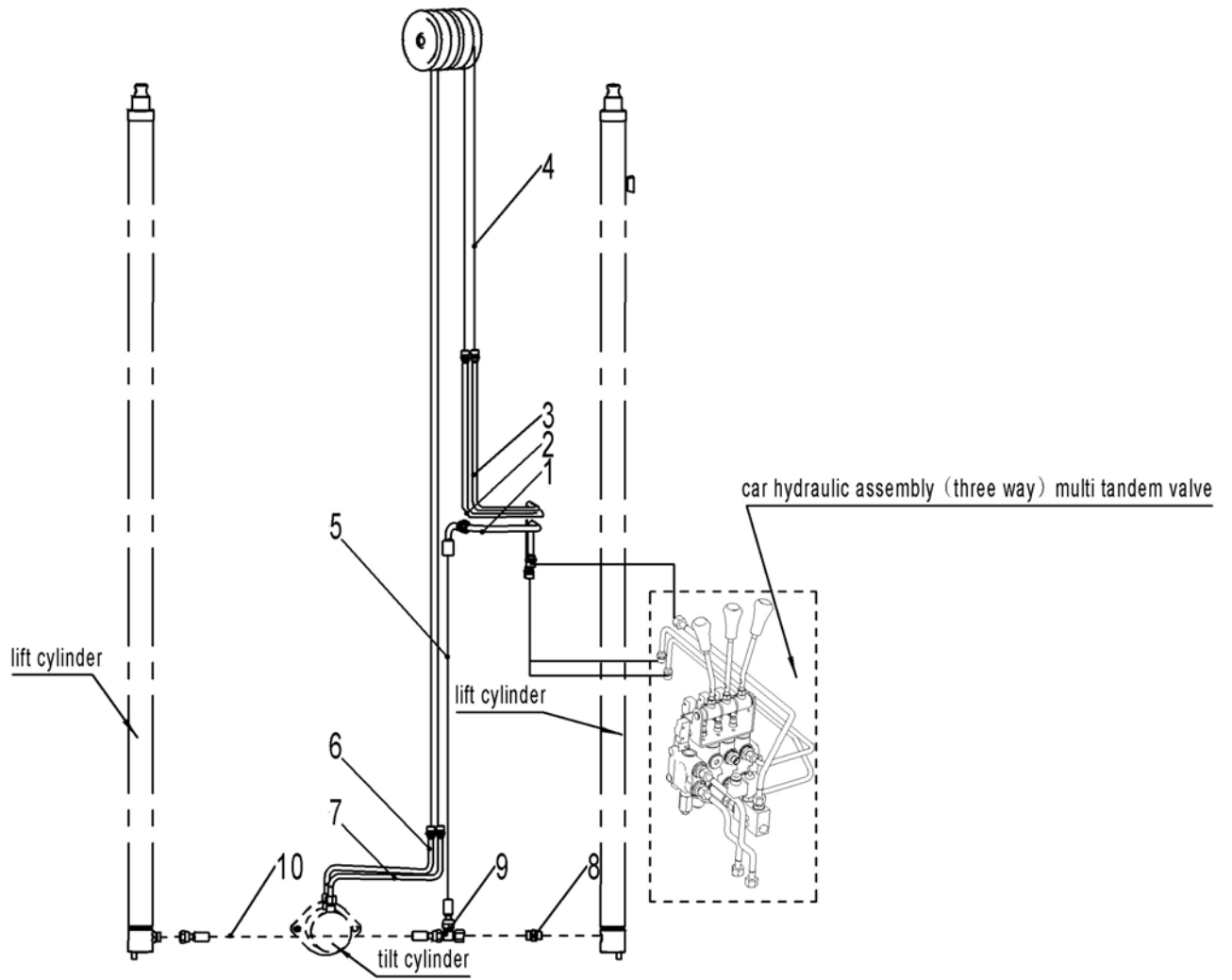

**Fig. 19 Two Stage Mast Hydraulic Pipeline (three ways)**

No.	Art No.	Description	Qty.	Note
1	201044520070	Hydraulic pipe welding 6	1	
2	201044520071	Hydraulic pipe welding 7	1	
3	201044520072	Hydraulic pipe welding 8	1	
4	201544502013	Hydraulic hose assembly 1 collective	1	
5	201044520087	Hydraulic hose assembly (90°)	1	12-L820-2SC-24°
6	201544020000	Hydraulic pipe welding 1	1	
7	201544020001	Hydraulic pipe welding 2	1	
8	950400400004	Joint (straight)	2	12-M16x1.5-M18x1.5-24°
9	950401000001	Joint (turning L)	1	12-3x18x1.5-24°
10	201544020003	Hydraulic hose assembly (straight)	1	12-L590-2SC-24°

Fig. 20 Two stage mast hydraulic pipeline (four ways)

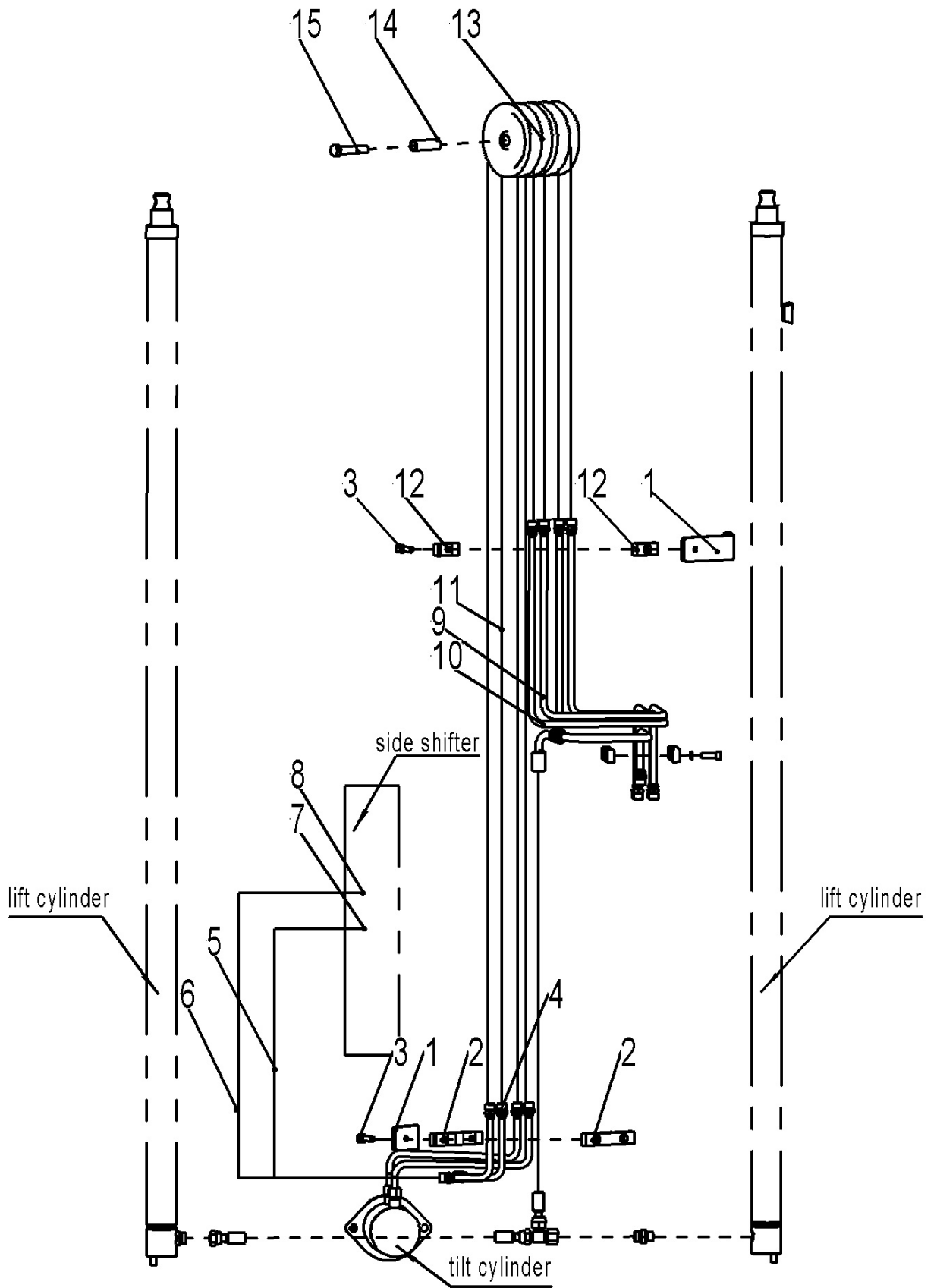

**Fig. 20 Two Stage Mast Hydraulic Pipeline (four ways)**

No.	Art No.	Description	Qty.	Note
1	201030520011	Assembly plate 4 (Pipe clamp)	1	
2	201038020012	Pipe clamp	4	4x10-8
3	91020020058	Screw	2	GB70.1-M8X25-8.8
4	201027520000	Hydraulic pipe welding 5	2	
5	201027520002	Hydraulic hose assembly (90°)	1	10-L300-1SC-24
6	532624020013	Hydraulic hose assembly (straight)	1	10-L450-1SC-24°
7	950401100003	Joint	2	10-G1/4-M16X1.5-24°
8	201030520014	Damping fin	2	
9	201030520000	Hydraulic pipe welding 3	1	
10	201030520001	Hydraulic pipe welding 4	1	
11	201544502013	Hydraulic hose assembly 1 collective diagram	1	
12	201030520006	Assembly plate 1 (Pipe clamp)	1	
13	213030520007	Pulley	1	110X112
14	201030520007	Bushing	1	17X13X14
15	910100100061	Bolt	1	GB5782-M12X130-8.8

Fig. 21 Three stage mast hydraulic pipeline (three ways)

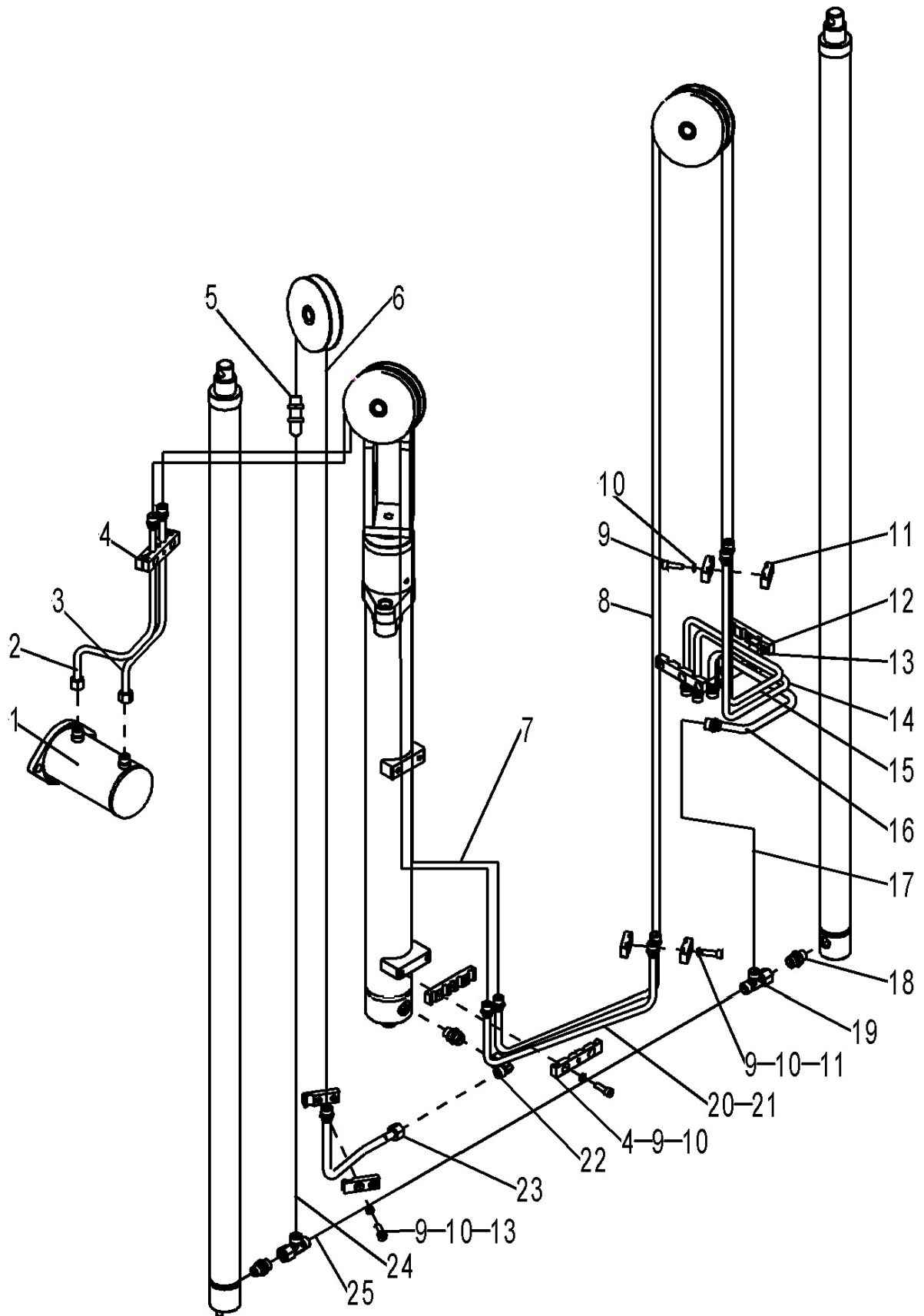
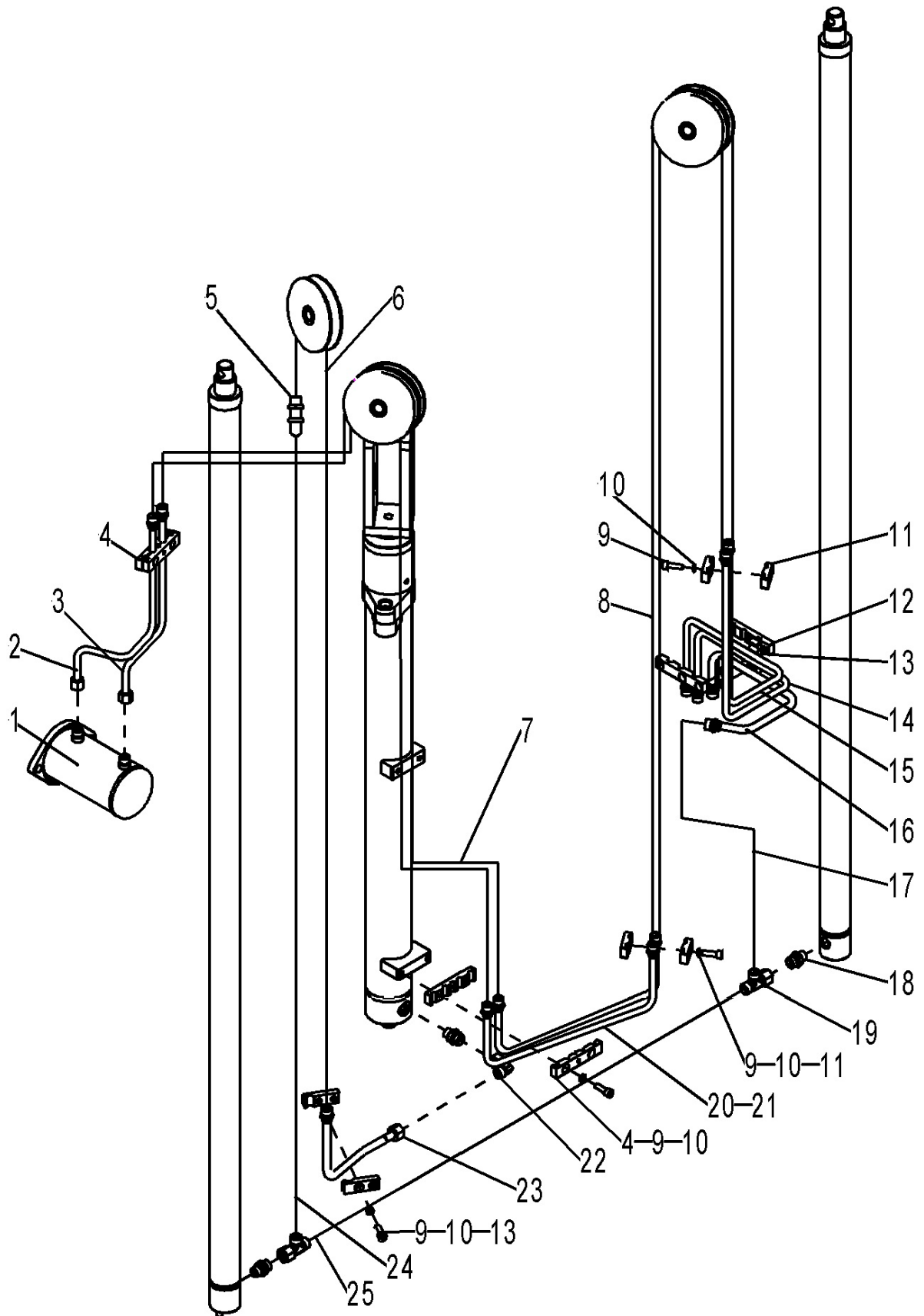

**Fig. 21 Three Stage Mast Hydraulic Pipeline (three ways)**

No.	Art No.	Description	Qty.	Note
1	201020510000	Tilt cylinder kits	1	
2	201044520074	Hydraulic pipe welding 10	1	
3	201044520073	Hydraulic pipe welding 9	1	
4	201038020012	Pipe clamp	4	4x10-8
5	950400600003	Joint	1	
6	201544520036	Hydraulic hose assembly 3 (straight)	1	4800
	201044520082	Hydraulic hose assembly 3 (straight)	1	4500
	201044520083	Hydraulic hose assembly 3 (straight)	1	3600
7	201043020015	Hydraulic hose assembly 2 (straight)	4	4800/1600
	201044520080	Hydraulic hose assembly 2 (straight)	4	4500
	201044520092	Hydraulic hose assembly 2 (straight)	4	3600/1200
8	201544520035	Hydraulic hose assembly 1 (straight)	2	4800
	201044520078	Hydraulic hose assembly 1 (straight)	2	4500/3000
	201044520092	Hydraulic hose assembly 1 (straight)	2	3600/2400
9	910200200058	Screw	10	GB70.1-M8x25-8.8
10	910400500006	Spring washer	10	GB93-8
11	201044520027	Pipe clamp	4	2x10
12	201038020012	Pipe clamp	6	4x10-8



Fig. 21 Three stage mast hydraulic pipeline (three ways)



**Fig. 21 Three Stage Mast Hydraulic Pipeline (three ways)**

No.	Art No.	Description	Qty.	Note
13	201044520022	Pipe clamp	2	2x10-12
14	201044520072	Hydraulic pipe welding 8	1	
15	201044520071	Hydraulic pipe welding 7	1	
16	201044520070	Hydraulic pipe welding 6	1	
17	201044520087	Hydraulic hose assembly (90°)	1	
18	950400400004	Joint (straight)	3	
19	950401000001	Joint (turning L)	2	
	201044520082	Hydraulic hose assembly 3 (straight)	1	4500
	201044520083	Hydraulic hose assembly 3 (straight)	1	3600
20	201530520000	Hydraulic pipe welding 1	1	
21	201530520001	Hydraulic pipe welding 2	1	
22	950400200004	Joint (turning)	1	
23	201544520033	Hydraulic pipe welding 3	1	
24	201544520037	Hydraulic hose assembly4 (90°)	1	
	201044520084	Hydraulic hose assembly4 (90°)	1	
	201044520085	Hydraulic hose assembly4 (90°)	1	
25	201044520087	Hydraulic hose assembly (90°)	1	

Fig. 22 Three stage mast hydraulic pipeline (four ways)

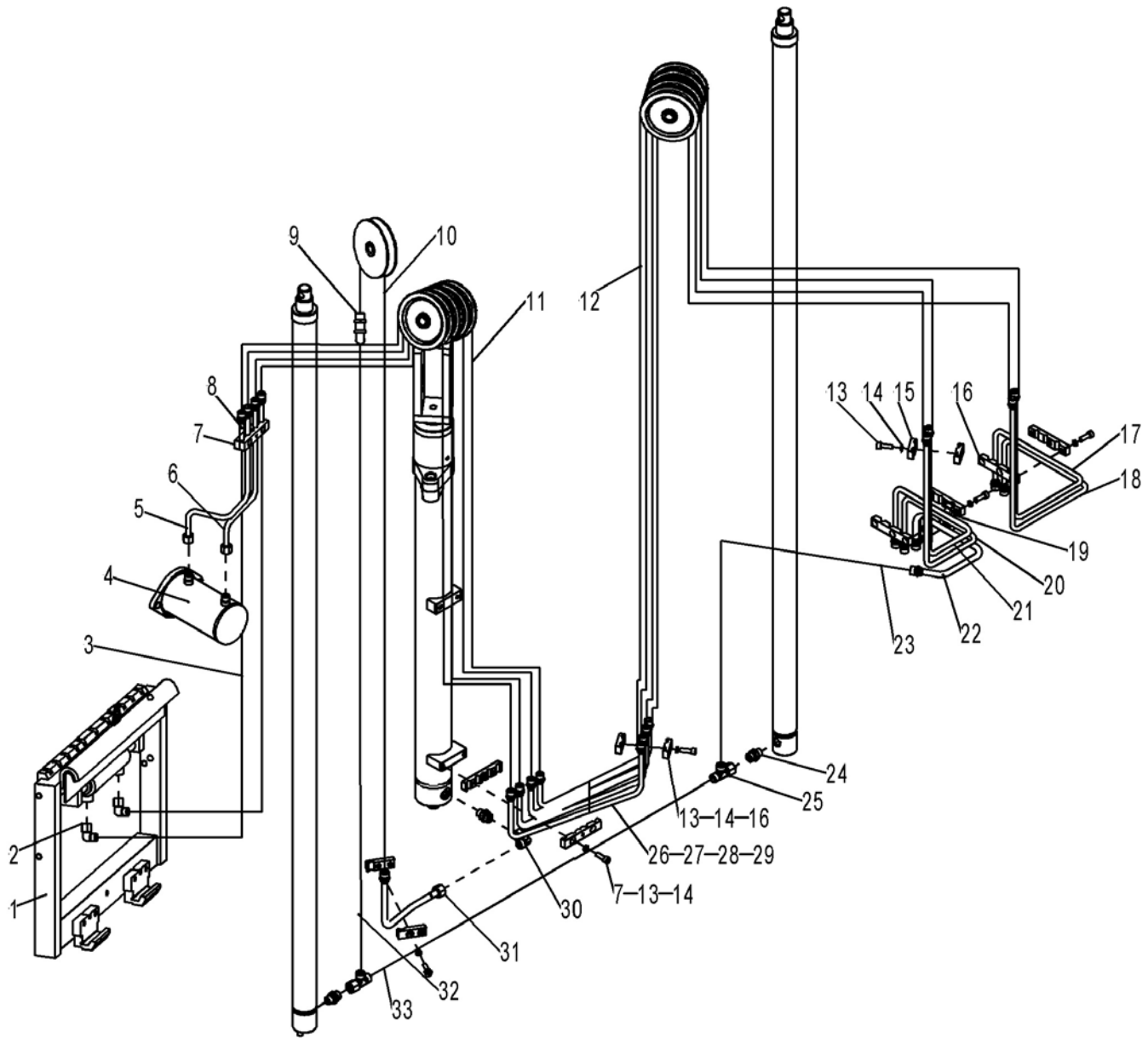

**Fig. 22 Three Stage Mast Hydraulic Pipeline (four ways)**

No.	Art No.	Description	Qty.	Note
1	940100200001	Side shifter	1	GC20NL
2	950401100003	Joint	2	
3	201030520013	Hydraulic hose assembly (90°)	2	
4	201020510000	Tilt cylinder	1	
5	201044520074	Hydraulic pipe welding 10	1	
6	201044520073	Hydraulic pipe welding 9	1	
7	201030520012	Hydraulic pipe welding 10	2	
8	201030520012	Hydraulic pipe welding 10	2	
9	950400600003	Joint	1	
10	201544520036	Hydraulic hose assembly 3 (straight)	1	4800
	201044520082	Hydraulic hose assembly 3 (straight)	1	4500
	201044520083	Hydraulic hose assembly 3 (straight)	1	3600
11	201043020015	Hydraulic hose assembly 2 (straight)	4	4800/1600
	201044520080	Hydraulic hose assembly 2 (straight)	4	4500
	201044520092	Hydraulic hose assembly 2 (straight)	4	3600/1200
12	201544520035	Hydraulic hose assembly 1 (straight)	2	4800
	201044520078	Hydraulic hose assembly 1 (straight)	2	4500/3000
	201044520092	Hydraulic hose assembly 1 (straight)	2	3600/2400

Fig.22 Three stage mast hydraulic pipeline (four ways)

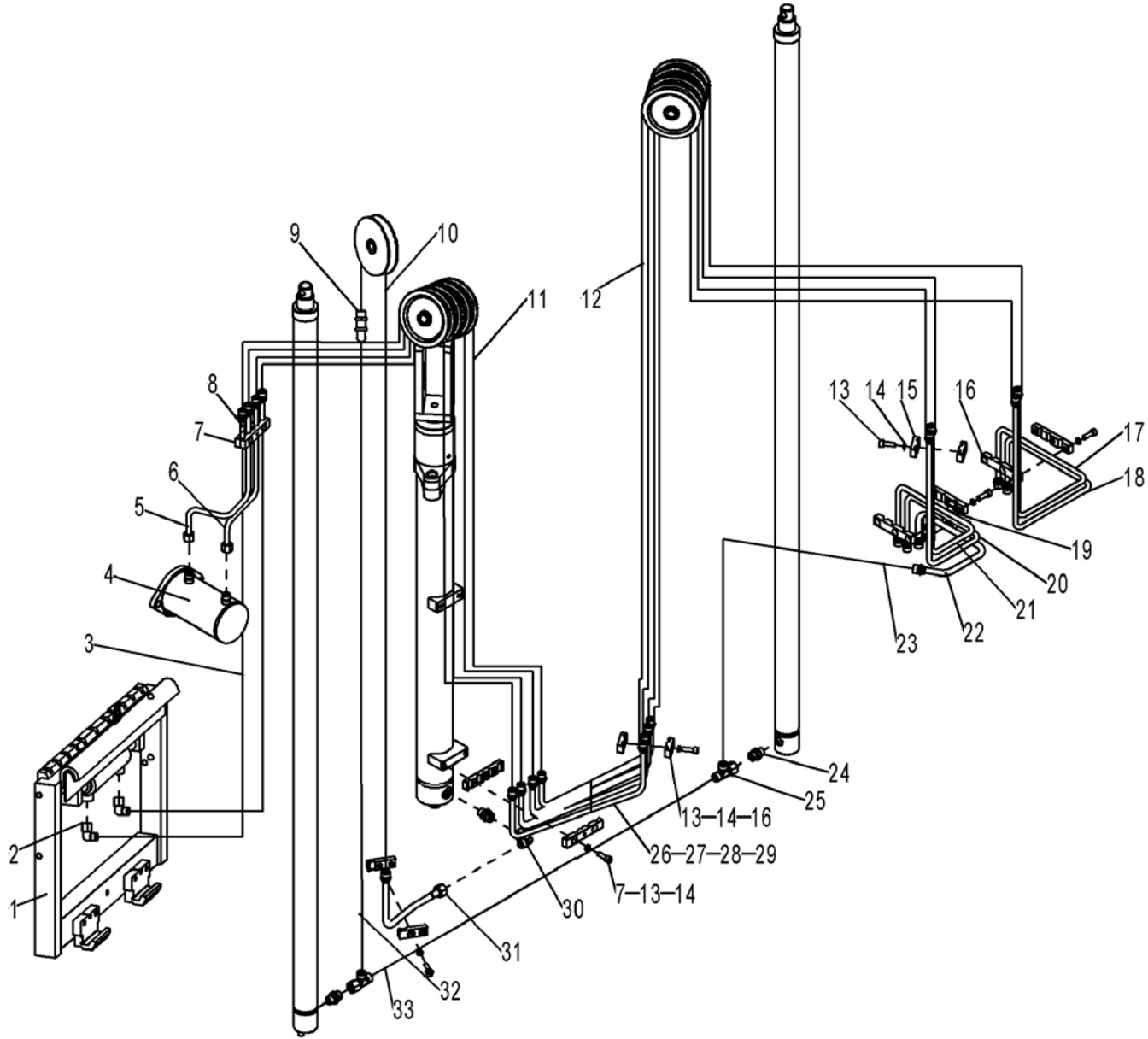

**Fig. 22 Three Stage Mast Hydraulic Pipeline (four ways)**

13	910200200058	Screw	10	GB70.1-M8x25-8.8
14	910400500006	Spring washer	10	GB93-8
15	201044520027	Pipe clamp	4	2x10
16	201038020012	Pipe clamp	8	4x10-8
17	201030520001	Hydraulic pipe welding 4	1	
18	201030520000	Hydraulic pipe welding 3	1	
19	201044520022	Pipe clamp	2	2x10-12
20	201044520072	Hydraulic pipe welding 8	1	
21	201044520071	Hydraulic pipe welding 7	1	
22	201044520070	Hydraulic pipe welding 6	1	
23	201044520087	Hydraulic hose assembly	1	
24	950400400004	Joint	3	
25	950401000001	Joint	2	
26	201530520000	Hydraulic pipe welding 1	1	
27	201530520001	Hydraulic pipe welding 2	1	
28	201530520002	Hydraulic pipe welding 3	1	
29	201530520003	Hydraulic pipe welding 4	1	
30	950400200004	Turning connecting joint	1	
31	201544520033	Hydraulic pipe welding 13	1	

Fig. 22 Three stage mast hydraulic pipeline (four ways)

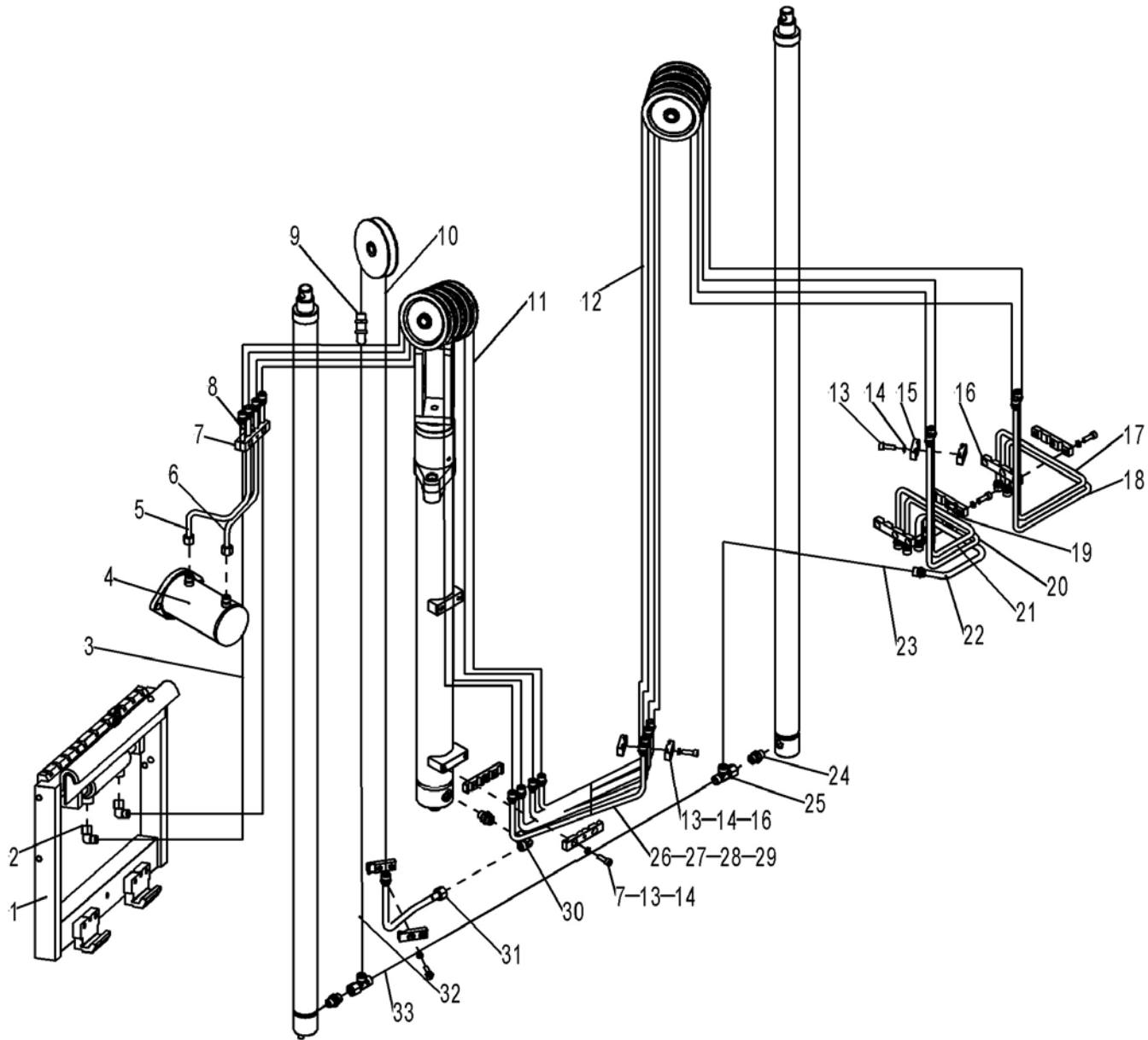
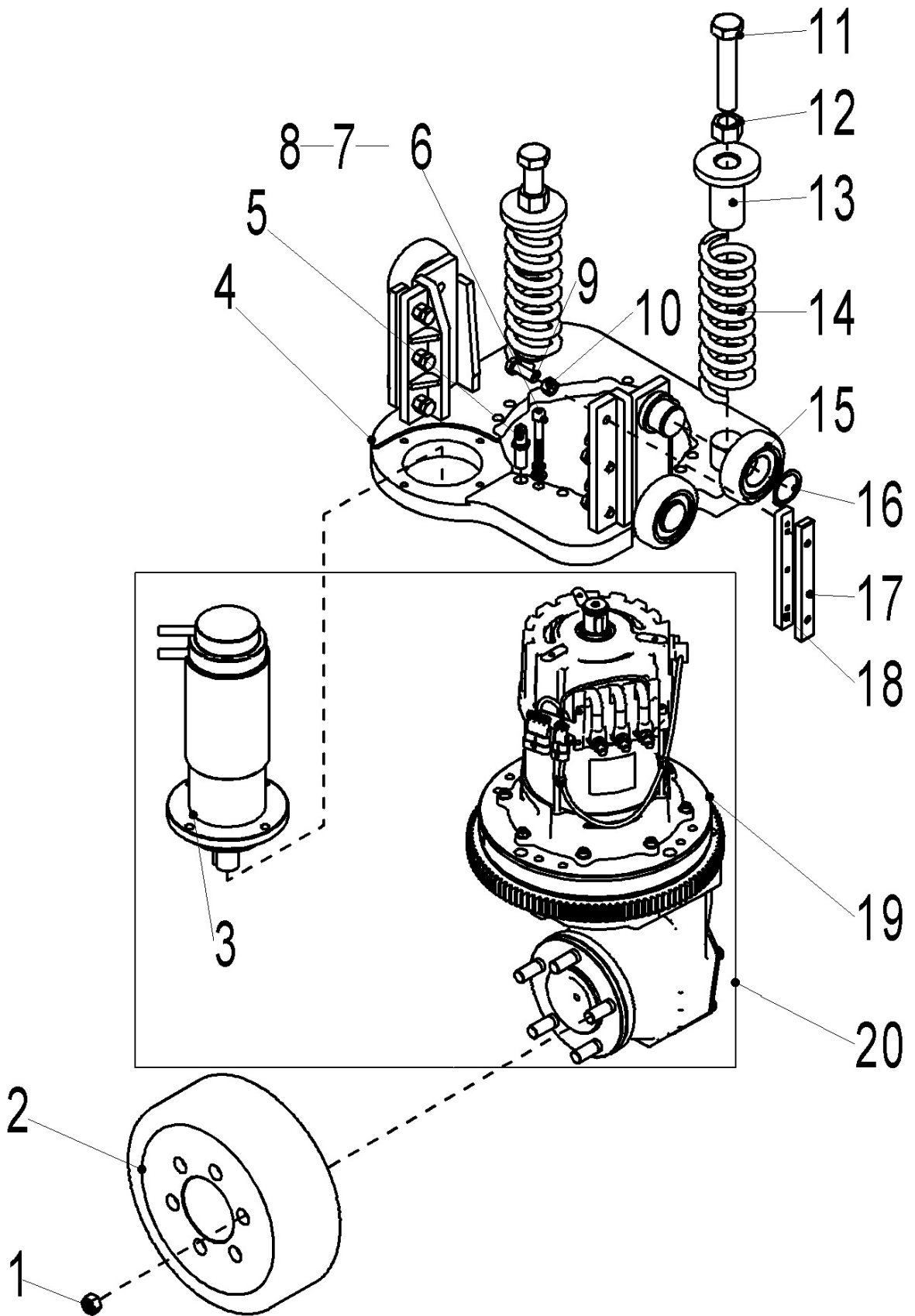

**Fig. 22 Three Stage Mast Hydraulic Pipeline (four ways)**

32	201544520037	Hydraulic hose assembly 4 (90°)	1	
	201044520084	Hydraulic hose assembly 4 (90°)	1	
	201044520085	Hydraulic hose assembly 4 (90°)	1	
33	201044520087	Hydraulic hose assembly (90°)	1	



Fig. 23 Drive assembly



**Fig.23 Drive Assembly**

No.	Art No.	Description	Qty.	Note
1	275015520005	Nut	5	
2	940300400002	Drive wheel	1	250x82
3	940900600004	Drive turning assembly	1	5.53.534.0-AC-2.6KW
4	201013510001	Drive wheel frame welding	1	
5	505733510001	Proximity switch	1	
6	910200200064	Screw	6	GB70.1-M8x55-8.8
7	910400500006	Spring washer	6	GB93-8
8	910400100006	Flat washer	6	GB97.1-8-200HV
9	910100300037	Bolt	6	GB5783-M10x30-8.8
10	910300100007	Nut	6	GB6170-M10-10
11	910100300088	Bolt	2	GB5783-M20x100-8.
12	910300100012	Nut	2	GB6170-M20-10
13	216513520003	Damping spring guide rod	2	
14	201013520011	Damping spring	2	50x10x197
15	940200100011	Main roller	4	
16	910401300018	Circlip	4	GB894.1-35
17	940500500001	Self lubricating wear plate	2	18x150x10
18	201013520000	Spherical hinge assembly plate	2	

Fig. 23 Drive assembly

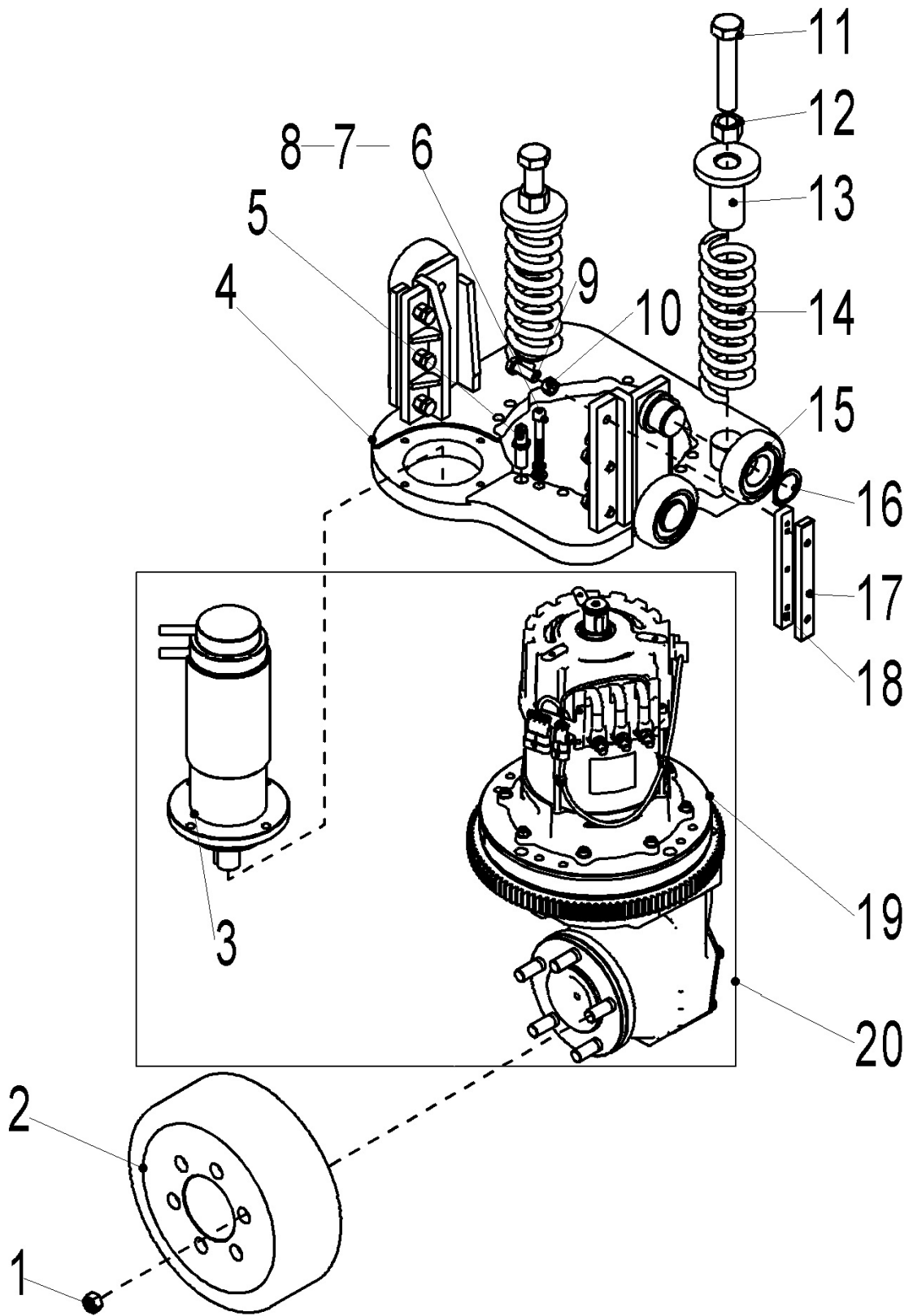

**Fig. 23 Drive Assembly**

No.	Art No.	Description	Qty.	Note
19	940900700001	DC turning assembly	1	002100006G-DC-0.6 KW
20	940900600003	Drive turning assembly	1	5.53.532.0-AC-2.6KW

Fig. 24 Cylinder function group

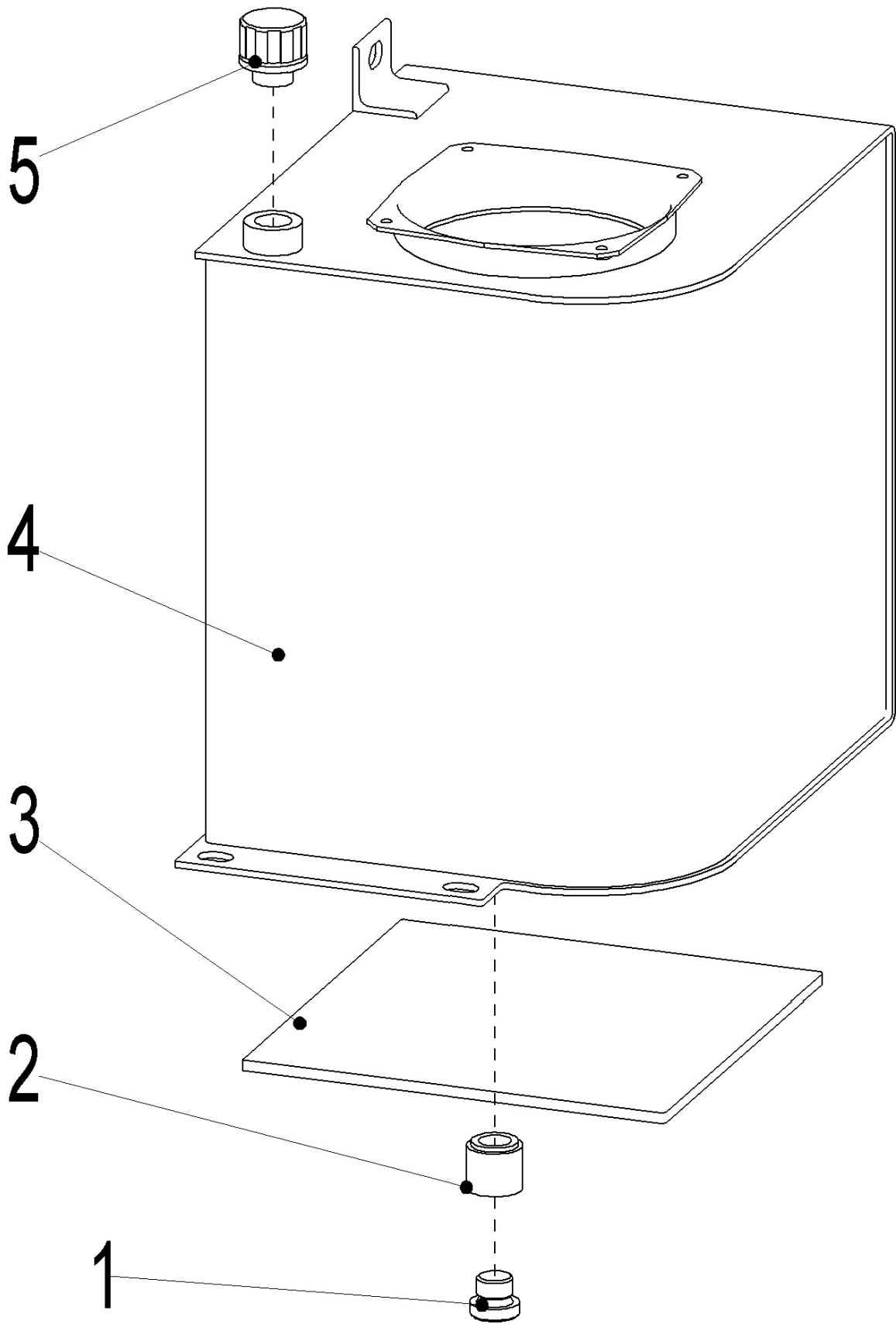

**Fig. 24 Cylinder Function Group**

No.	Art No.	Description	Qty.	Note
1	911300100001	Screw plug	1	JB1000-M16x1.5
2	910800900005	Bonded seal	1	JB982-16
3	201019020004	Rubber mat	1	200x200x5
4	201019010000	Cylinder welding	1	
5	951100200001	Airplug M18x1.5	1	M18x1.5

**Fig. 25 Load roller**

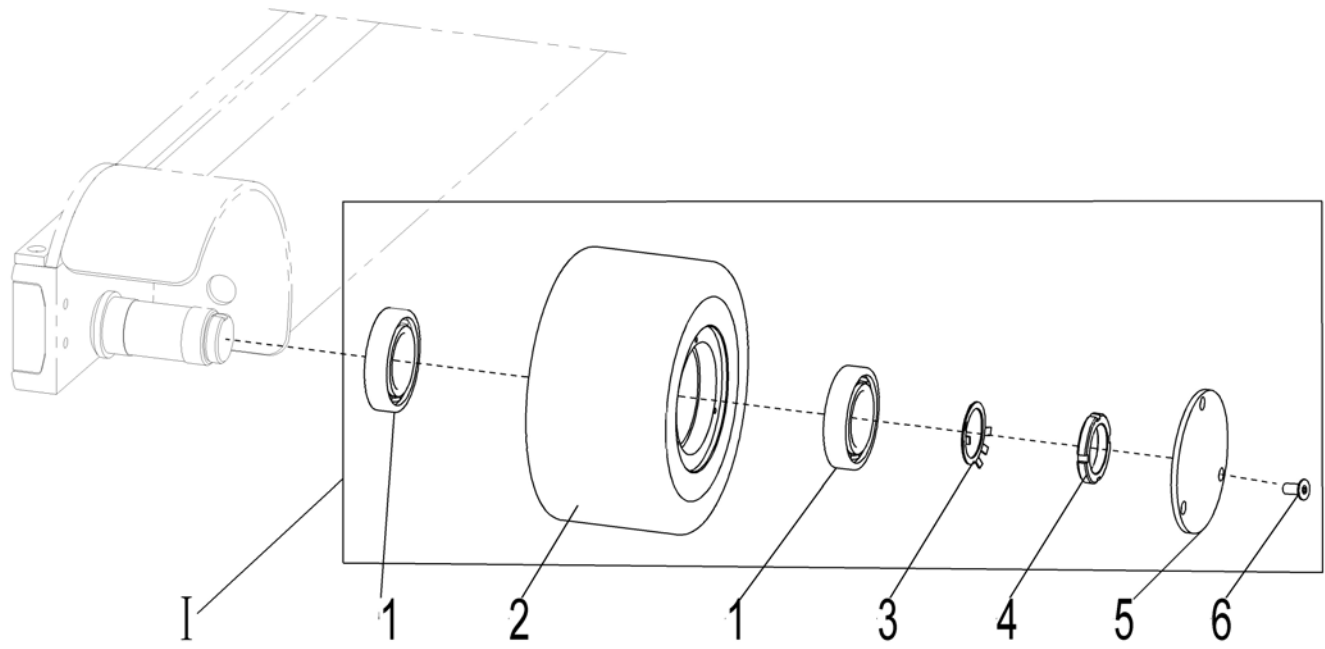
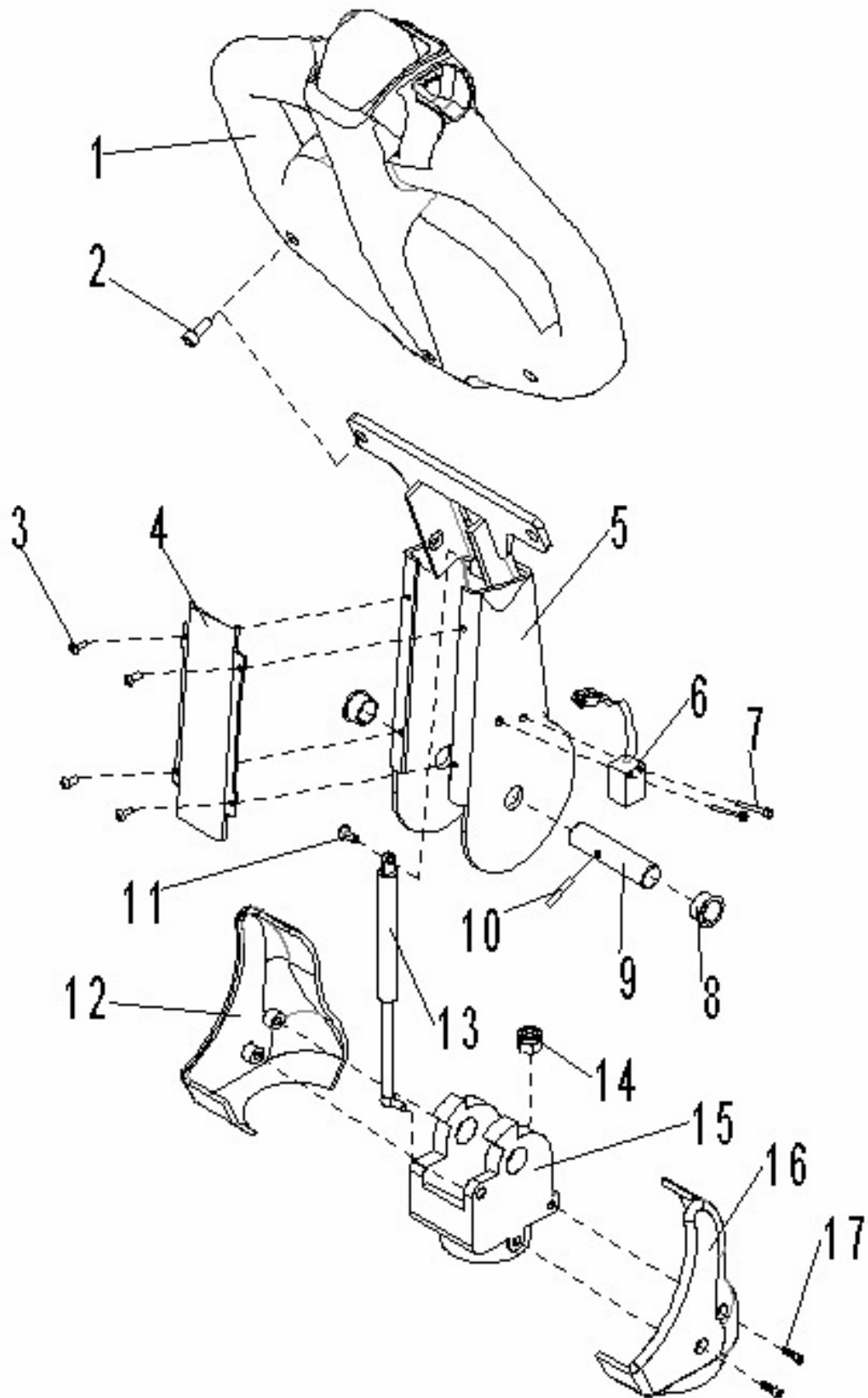

**Fig. 25 Load Roller**

No.	Art No.	Description	Qty.	Note
I	201017001000	Load roller assembly	2	
1	910700200023	Bearing	2	6208
2	940300300024	Front roller	1	
3	910400900007	Washer	1	36
4	910300700002	Nut	1	M36
5	201017020000	End cap	1	
6	910200400016	Screw	3	M6×12



Fig. 26 Tiller kits



**Fig. 26 Tiller Kits**

No.	Art No.	Description	Qty.	Note
1	922100100001	Carbus control tiller C	1	94300-90(REMA)
2	910200200058	Bolt thread	2	GB70.1-M8x25-8.8
3	910200300005	Screw	4	GB70.2-M4x8-8.8
4	505611020006	Cover plate	1	
	505611020013	Long Cover plate	1	
5	505611010000	Tiller arm welding	1	
	505611010001	Long Tiller arm welding	1	
6	505633510000	Proximity switch	1	NBN5-F7-E2(370 mm)
7	910200500015	Screw	2	GB818-M3x20-4.8
8	940500200002	Bushing with shoulder	2	17×19×11
9	505611020008	Tiller axle	1	
10	910600400013	Elastic cylindrical pin	1	GB879.1-4x24
11	910200200057	Screw	1	GB70.1-M8x20-8.8
12	505611020010	Left tiller cover	1	
13	940400100002	Air spring	1	400N
	940400100003	Air spring	1	450N
14	950300100003	Nut	2	10-M16x1.5-24°
15	505611020009	Tiller seat	1	
16	505611020011	Right tiller cover	1	
17	910200300016	Screw	4	GB70.2-M6x10-8.8

Fig. 27 Tiller head

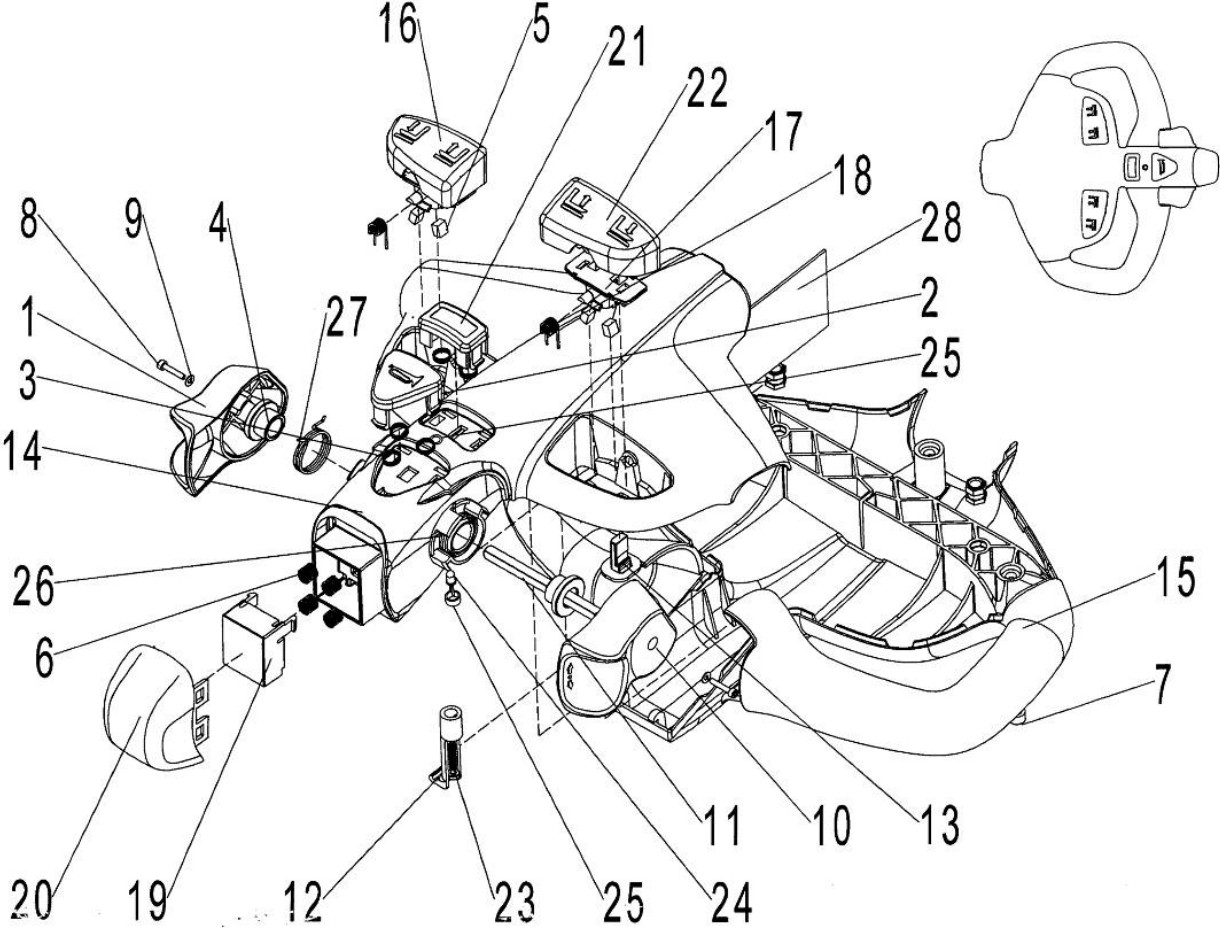

**Fig. 27 Tiller Head**

No.	Art No.	Description	Qty.	Note
1	505698520001	Left driving knob	1	
2	505698520002	Horn button	1	
3	505698520003	Horn button assembly spring	5	
4	505698520004	Cam axle bushing	2	
5	505698520005	Magnet	4	
6	505698520006	Emergency switch spring	4	
7	505698520007	Screw	3	GB70.1-M6X10-8.8
8	505698520008	Screw	2	GB70.1-M3x16-8.8
9	505698520009	Flat washer	2	GB97.1-3-200HV
10	505698520010	Right driving knob	1	
11	505698520011	Driving button connecting axle	1	
12	505698520012	PCB connecting terminal	1	
13	505698520013	Pressure sensor	2	
14	505698520014	Top part of tiller head	1	
15	505698520015	Bottom part of tiller head	1	
16	505698520016	Left lifting button	1	
17	505698520017	Magnet assembly seat	2	
18	505698520018	Torsional spring	2	

Fig. 27 Tiller head

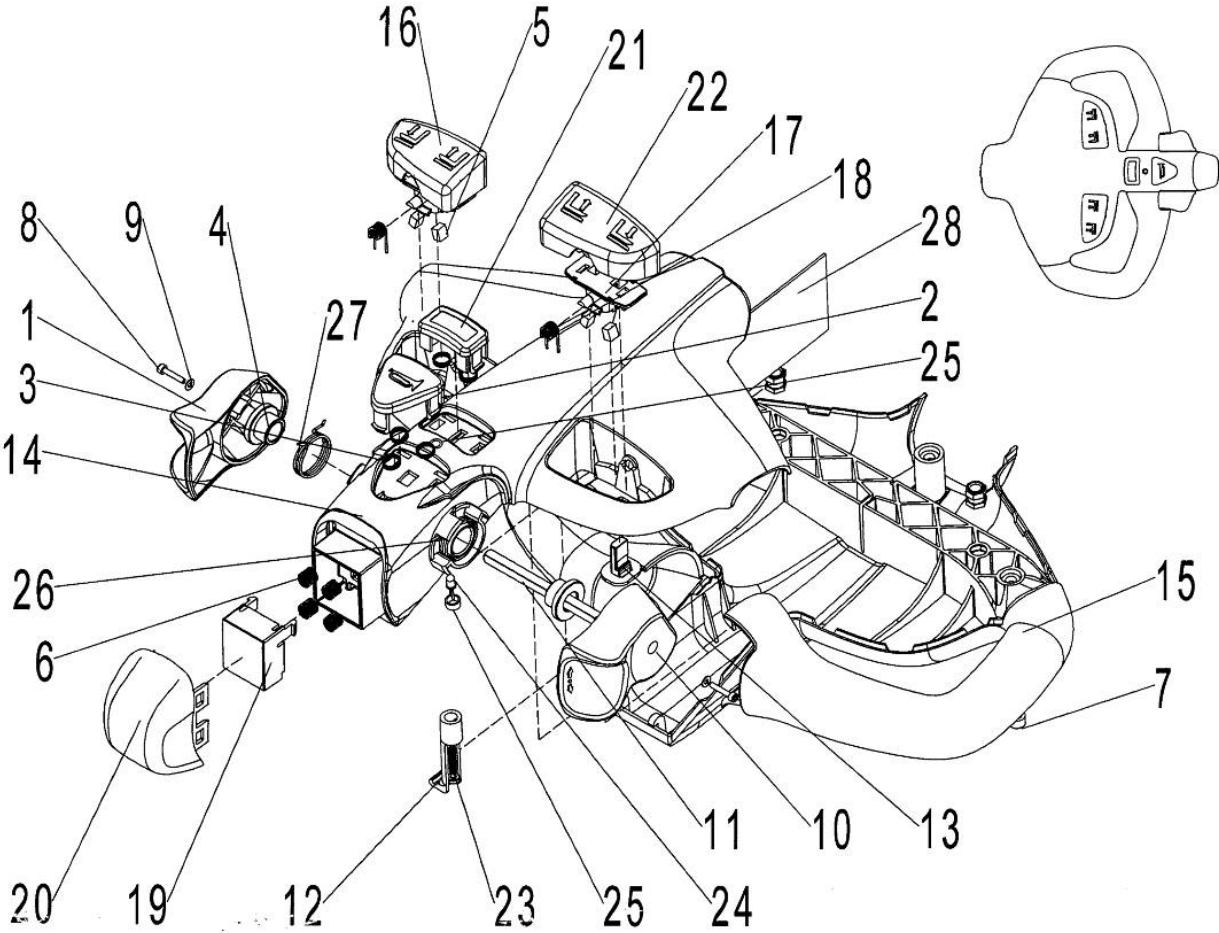

**Fig. 27 Tiller Head**

No.	Art No.	Description	Qty.	Note
19	505698520019	Emergency switch spring assembly seat	1	
20	505698520020	Emergency Button	1	
21	505698520021	Switch cover	1	
22	505698520022	Right lifting and lowering button	1	
23	505698520023	Screw	1	GB845-ST4.2x25
24	505698520024	LED bi colored light	1	
25	505698520025	LED bi colored light assembly seat	1	
26	505698520026	Torsional spring of left driving button	1	
27	505698520027	Torsional spring of right driving button	1	
28	505698520028	PCB	1	

**Fig. 28 Protective arm assembly**

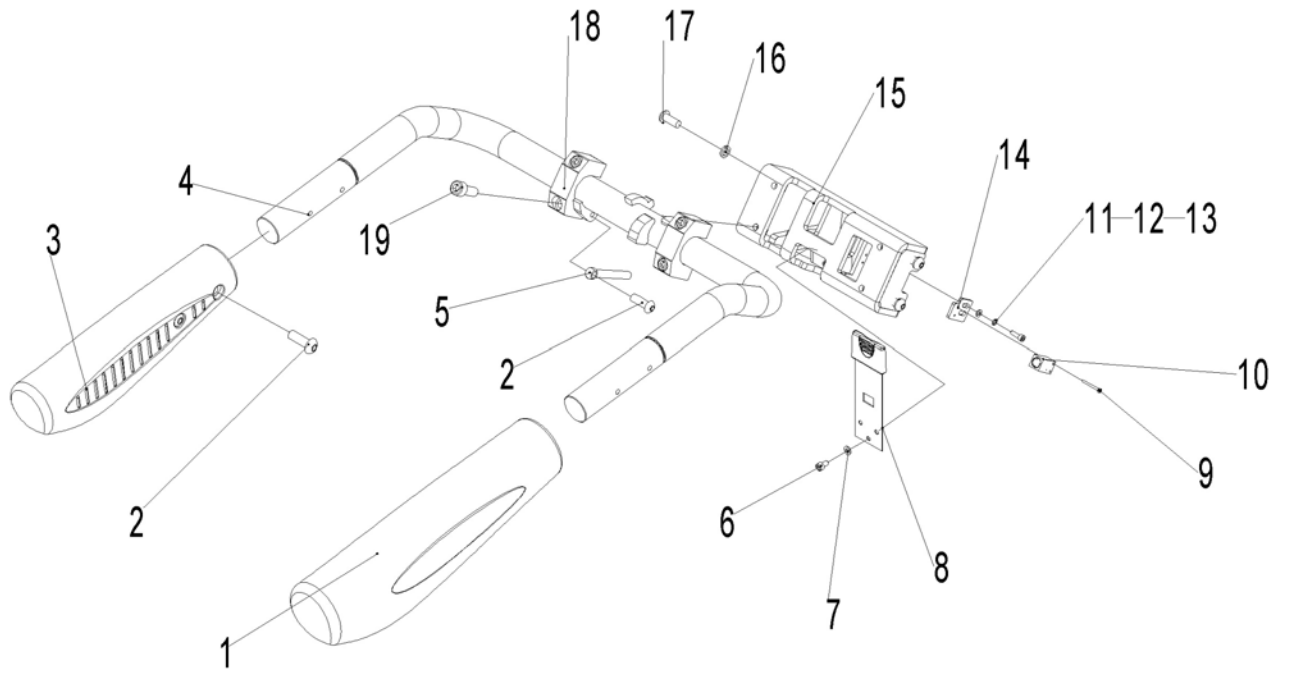
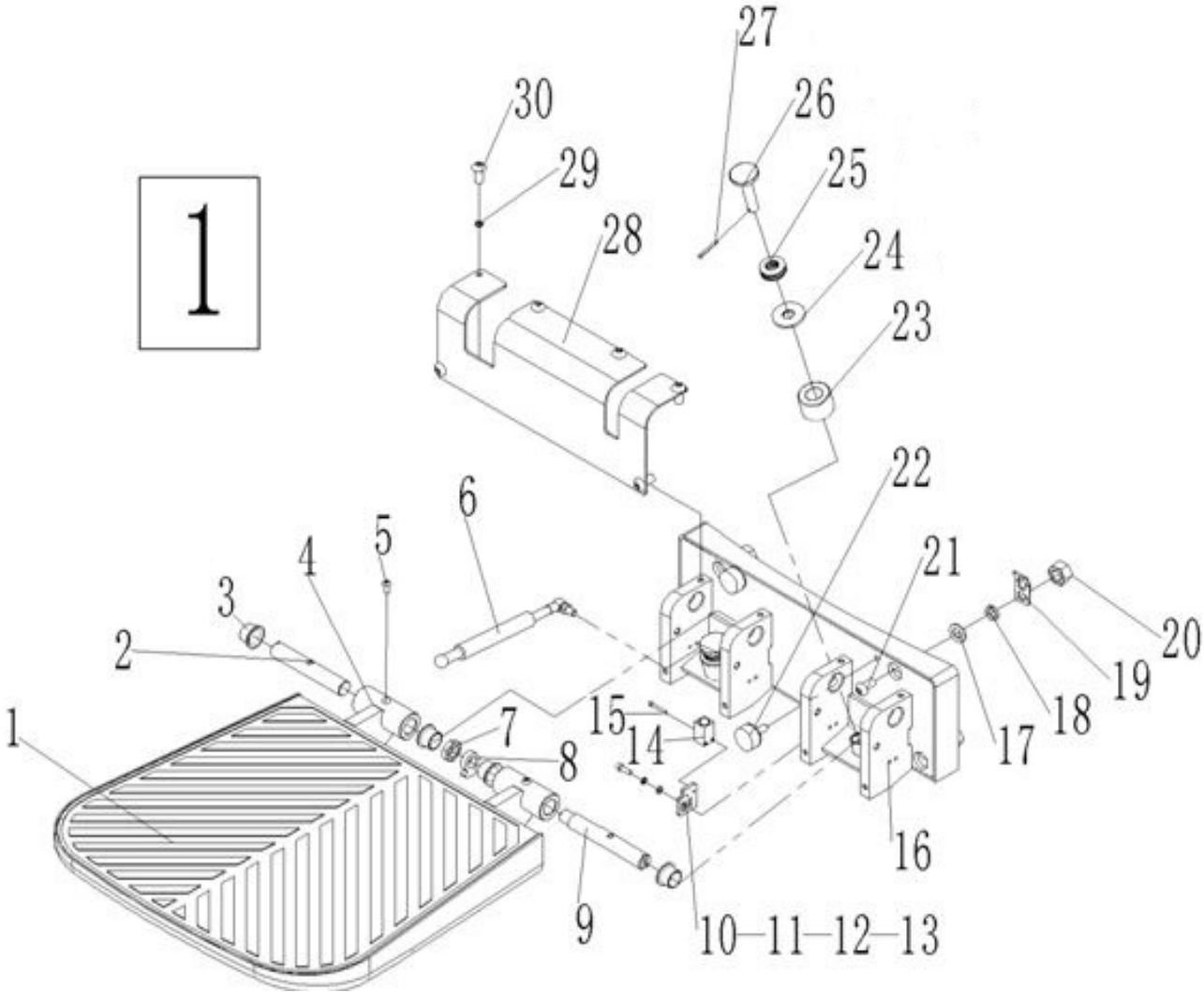

**Fig. 28 Protective Arm Assembly**

No.	Art No.	Description	Qty.	Note
1	505617510002	Right protective arm bushing	1	
2	910200300025	Screw	5	GB70.2-M8x20-8.8
3	505617510004	Left protective arm bushing	1	
4	505617510001	Protective arm welding	1	
5	940400100006	Air spring	1	
6	910200300017	Screw	3	GB70.2-M6x12-8.8
7	910400500005	Spring washer	3	GB93-6
8	505617510005	Position spring	1	
9	910200500015	Screw	2	GB818-M3x20-4.8
10	505633510001	Proximity switch	1	NBN5-F7-E5
11	910400500004	Spring washer	2	GB93-5
12	910400100004	Flat washer	2	GB97.1-5-200HV
13	910200200023	Screw	2	M5×16
14	505618020026	Switch transition plate	1	
15	505617510000	Protective arm base welding	1	
16	910400500007	Spring washer	4	GB93-10
17	910100300036	Screw	4	GB5783-M10x25-8.8
18	505617520005	Protective arm clamp block	2	
19	910200200080	Screw	4	GB70.1-M10x45-8.8



Fig. 29 Platform assembly



**Fig. 29 Platform Assembly**

No.	Art No.	Description	Qty.	Note
1	505618020018	Platform pad	1	
2	505618020020	Axle	1	
3	940500200008	Bushing with shoulder	4	
4	505618010000	Platform welding	1	
5	910200300018	Screw	2	GB70.2-M6x16-8.8
6	940400100008	Air spring	1	
7	910300400006	Nut	1	GB6173-M16x1.5-05
8	505618020024	Cam	1	
9	505618020017	Cam axle	1	
10	910400500004	Spring washer	2	GB93-5
11	910400100004	Flat washer	2	GB97.1-5-200HV
12	910200200023	Screw	2	GB70.1-M5x16-8.8
13	505618020026	Switch transition plate	1	
14	505633510002	Proximity switch	1	NBN5-F7-E2
15	910200500015	Screw	2	GB818-M3x20-4.8
16	505618010001	Assembly seat welding	1	
17	910400100008	Flat washer	4	GB97.1-12-200HV
18	910400500008	Spring washer	4	GB93-12

Fig. 29 Platform assembly

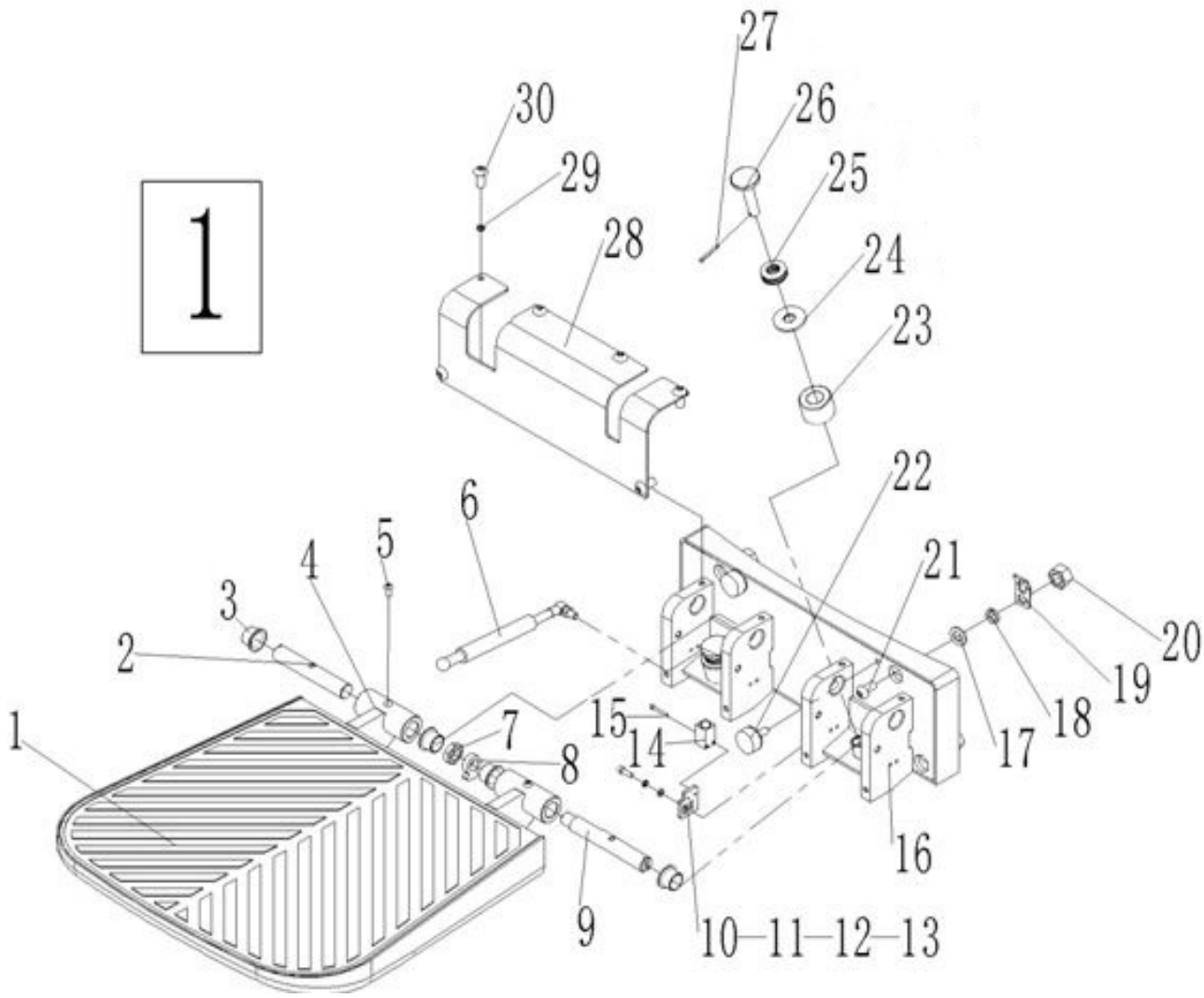

**Fig. 29 Platform Assembly**

No.	Art No.	Description	Qty.	Note
19	505618020025	Cable hanging plate	1	
20	910300500006	Nut	4	GB889.1-M12-10
21	910200200100	Screw	4	GB70.1-M12x40-8.8
22	505618020016	Damping pad	2	
23	505618020023	Anti vibration pad	2	
24	505618020022	Anti vibration washer	2	
25	911100100002	Spring	8	GB1972-A31.5-1
26	505618020021	Fixing bolt	2	
27	910600600026	Split pin	2	GB91-3.2x20
28	505618020019	Assembly seat main cover	1	
29	910400500005	Spring washer	6	GB93-6
30	910200300017	Screw	6	GB70.2-M6x12-8.8
①	505618001000	Platform assembly	1	

Fig. 30 Battery cover turning structure

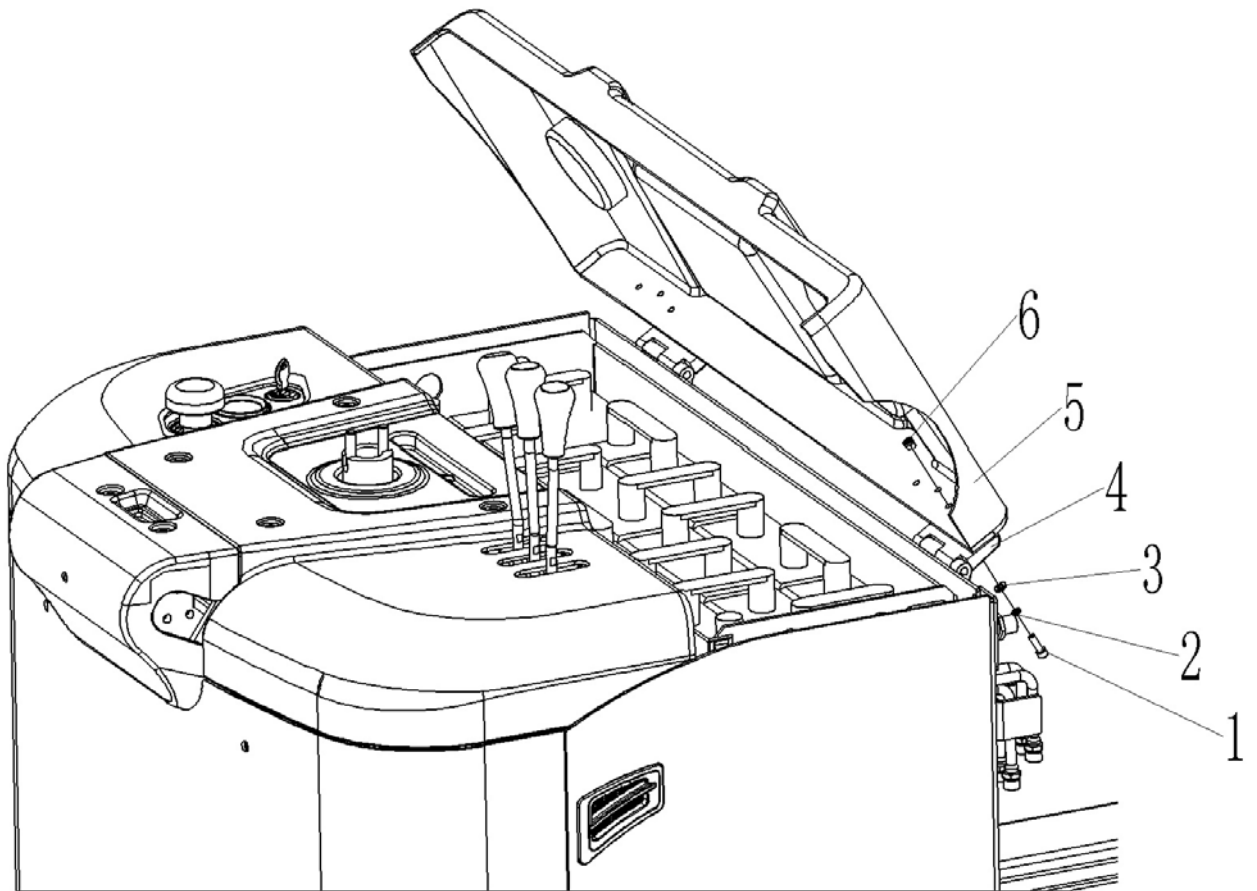

**Fig. 30 Battery Cover Turning Structure**

No.	Art No.	Description	Qty.	Note
1	910200200033	Screw	12	M6×16
2	910400500005	Standard elastic washer	12	6
3	910400100005	Flat washer	12	6
4	940801300001	Hinge kits	2	
5	206021020002	Battery cover	1	
6	910300500003	Nut	12	M6

Fig. 31 Steering wheel kits

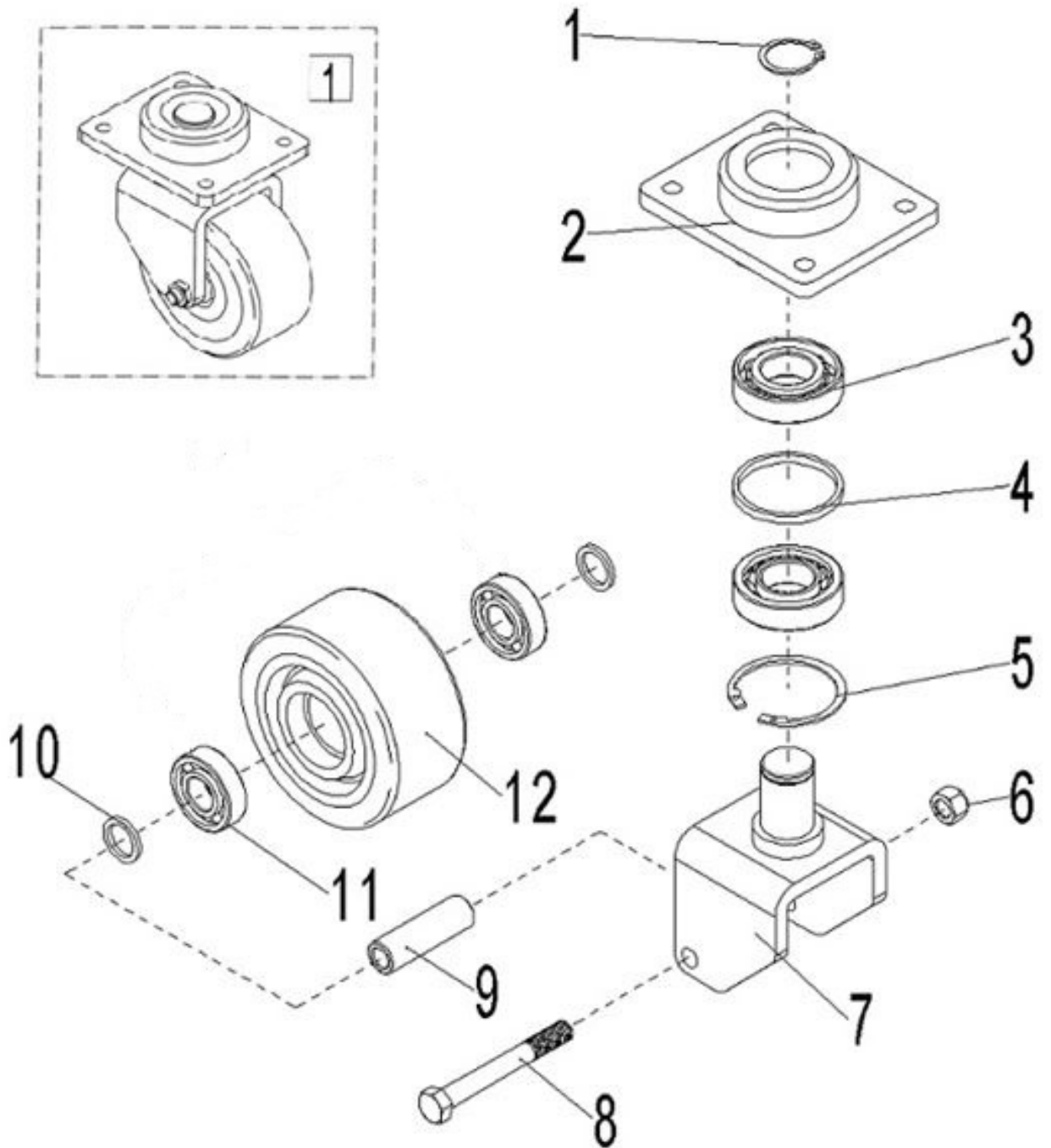
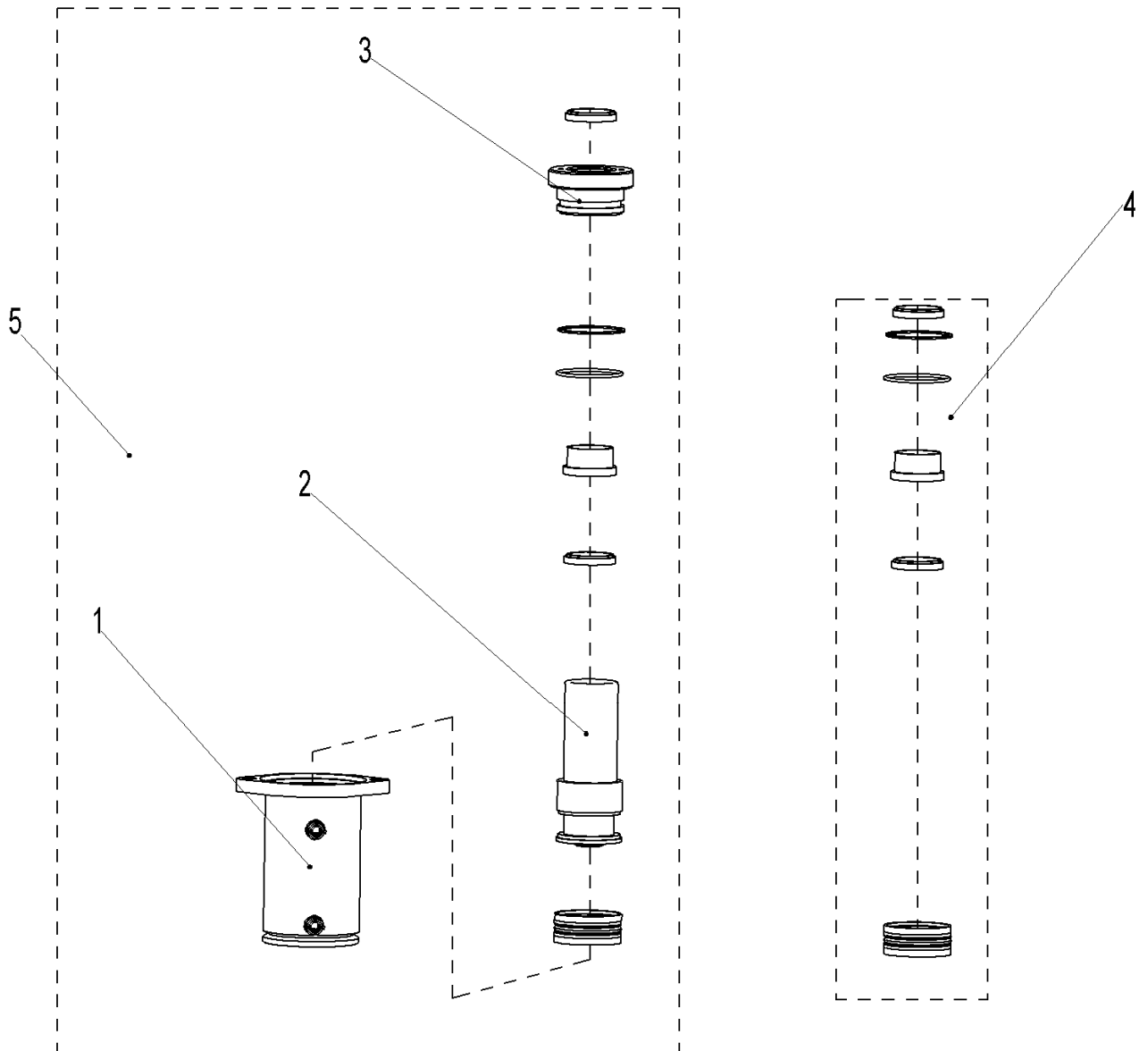

**Fig. 31 Turning Wheel Kits**

No.	Art No.	Description	Qty.	Note
1	910401300016	Circlip	1	30
2	532616520002	Bearing seat	1	
3	910700400004	Bearing	2	7206C/DB
4	532616520001	Spacer	1	
5	910401400018	Circlip	1	62
6	910300500007	Nut	1	M14
7	532616510001	Back wheel frame welding	1	
8	910100100069	Bolt	1	M14×100
9	532616520003	Bushing	1	
10	940600500014	Washer	2	
11	910700200019	Bearing	2	6204
12	940300300019	Wheel	1	124×60
1	532616510000	Steering wheel kits	2	



Fig. 32 Tilt cylinder



**Fig. 32 Tilt Cylinder**

No.	Art No.	Description	Qty.	Note
1	201598520011	Cylinder barrel	1	
2	201598520012	Piston rod	1	
3	201598520013	Guide bushing	1	
4	201598510004	Tilt cylinder sealing kits assembly	1	
5	201020510000	Tilt cylinder assembly	1	

Fig. 33 Truck body assembly

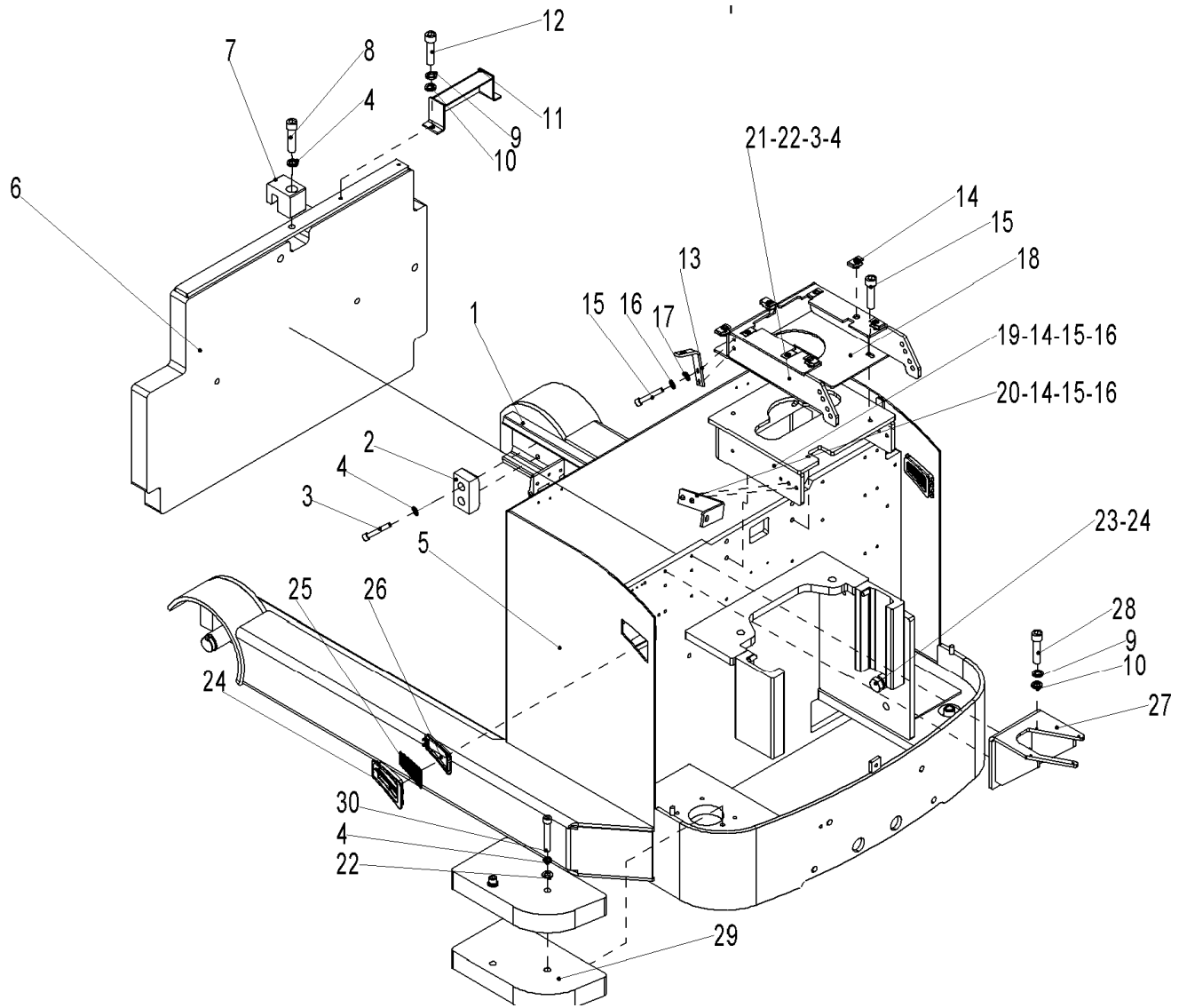

**Fig. 33 Truck Body Assembly**

No.	Art No.	Description	Qty.	Note
1	201521510000	Truck body welding	1	
2	216521520001	Damping block	2	
3	910200200098	Screw	8	GB70.1-M12X30-8.8
4	910400500008	Spring washer	12	GB93-12
5	201521510000	Apron welding (front)	1	
6	201021510008	Counterweight block welding	1	
7	201021520044	Battery limit block	1	
8	910200200102	Screw	2	GB70.1-M12X50-8.8
9	910400500006	Spring washer	8	GB93-8
10	910400100006	Flat washer	11	GB97.1-8-200HV
11	201021510002	Protective cover welding (multi tandem valve)	1	
12	910200200053	Screw	2	GB70.1-M8X12-8.8
13	201021520026	Fixing frame	2	
14	940400400003	Nut	11	M10-t(3-5)
15	910200200075	Screw	16	GB70.1-M10X20-8.8
16	910400500007	Spring washer	24	GB93-10
17	910400100007	Flat washer	24	GB97.1-10-200HV
18	201021520027	Supporting plate	1	

Fig. 33 Truck body assembly

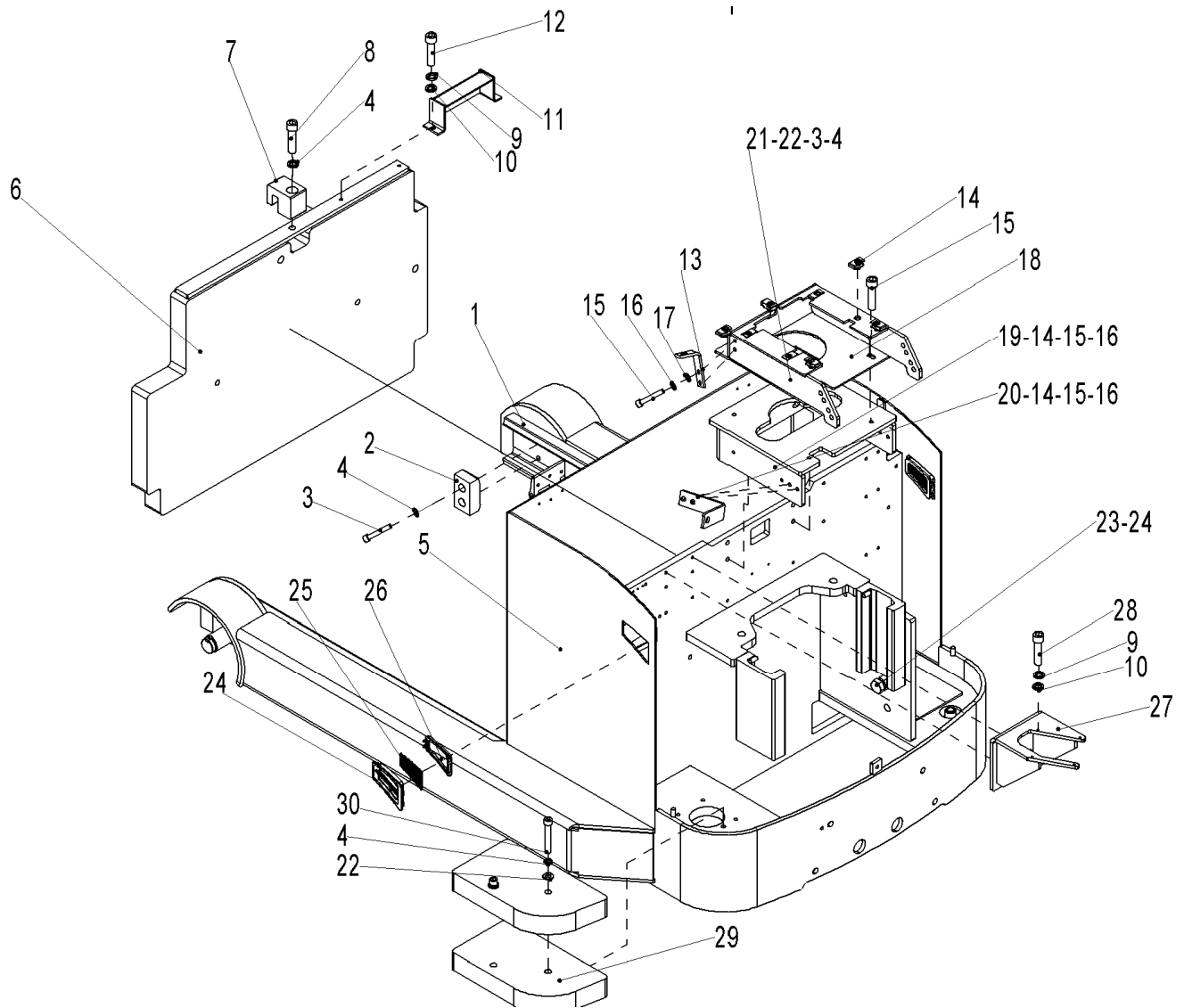

**Fig. 33 Truck Body Assembly**

No.	Art No.	Description	Qty.	Note
19	201021510003	Connecting seat welding	1	
20	201021510004	Fixing frame welding	1	
21	201021510005	Connecting seat welding (supporting)	1	
22	910400100008	Flat washer	6	GB97.1-12-200HV
23	910100100118	Bolt	3	GB5782-M20X40-8.8
24	910300100012	Nut	3	GB6170-M20-10
25	505621510003	Vent hole kits 1	1	
26	505621510004	Vent hole kits 2	1	
27	201021510007	Instrument base welding	1	
28	910200200058	Screw	13	GB70.1-M8X25-8.8
29	201021520040	Counterweight	2	
30	910100100061	Bolt	2	GB5782-M12X130-8.8

Fig. 34 Truck body assembly (sides way)

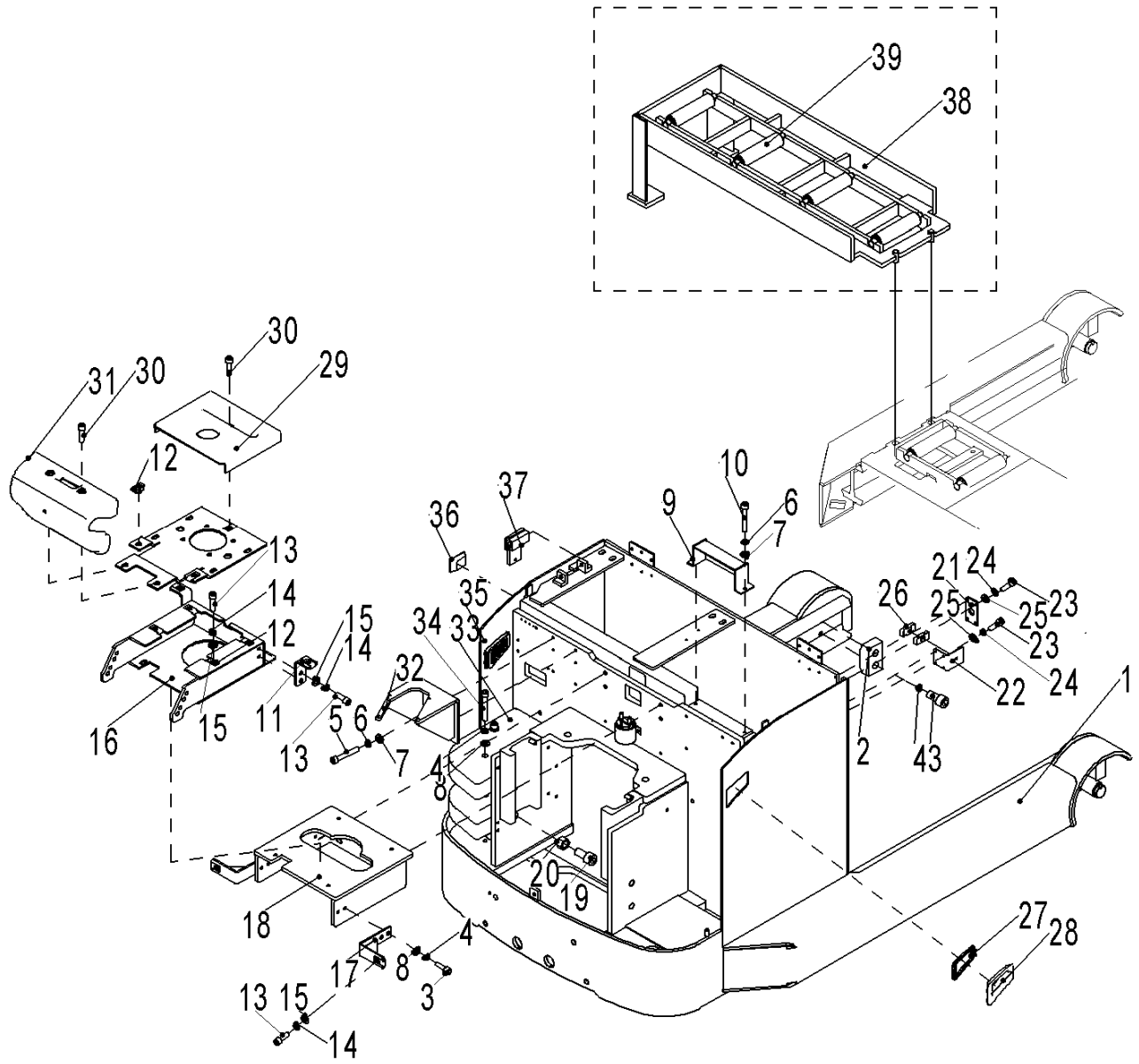
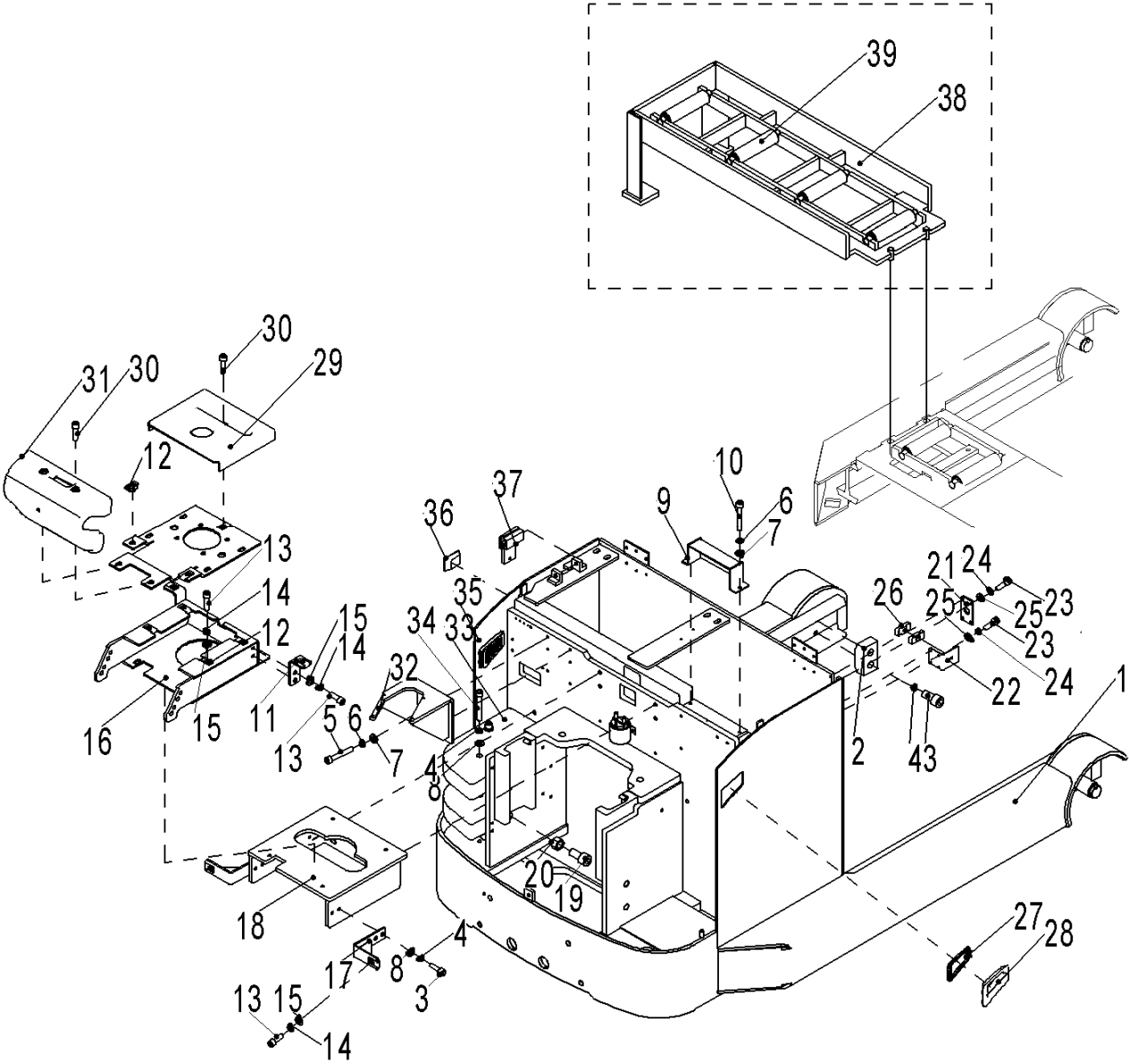

**Fig. 34 Truck Body Assembly (sides way)**

No.	Art No.	Description	Qty.	Note
1	201021510002	Truck body welding	1	
2	216521520001	Damping block	2	
3	910200200098	Screw	8	GB70.1-M12X30-8.8
4	91040050008	Washer	12	GB93-12
5	910200200058	Screw	10	GB70.1-M8X25-8.8
6	910400500006	Spring washer	10	GB93-8
7	910400100006	Flat washer	2	GB97.1-8-200HV
8	910400100008	Flat washer	8	GB97.1-12-200HV
9	201021510002	Protective cover welding (multi tandem valve)	1	
10	910200200053	Screw	2	GB70.1-M8X12-8.8
11	201021520026	Fixing frame	2	
12	940400400003	Nut	11	M10-t(3-5)
13	910200200075	Screw	16	GB70.1-M10X20-8.8
14	910400500007	Spring washer	24	GB93-10
15	910400100007	Flat washer	24	GB97.1-10-200HV
16	201021510003	Connecting seat welding	1	
17	201021510004	Fixing frame welding	2	
18	201021510005	Connecting seat welding (supporting)	1	



Fig. 34 Truck body assembly (sides way)



**Fig. 34 Truck Body Assembly (sides way)**

No.	Art No.	Description	Qty.	Note
19	910100100118	Bolt	3	GB5782-M20X40-8.8
20	910300100012	Nut	3	GB6170-M20-10
21	201021520035	Assembly plate	1	
22	201021520039	Assembly plate 5 (Pipe clamp)	1	
23	910200200032	Screw	8	GB70.1-M6X10-8.8
24	910400500005	Spring washer	8	GB93-6
25	910400100005	Flat washer	8	GB97.1-6-200HV
26	201044520027	Pipe clamp	2	3x10
27	505621510003	Vent hole kits 1	1	
28	505621510004	Vent hole kits 2	1	
29	206021520034	Protective cover (middle)	1	
30	941100100006	Screw	10	M10X45-8.8
31	505621520025	Protective cover (protective arm)	1	
32	201021510011	Instrument base welding	1	
33	201021520040	Counterweight	2	
34	910100100061	Bolt	2	GB5782-M12X130-8.8
35	203021510003	Left door welding	1	
36	940800300002	Panel lock	1	MS866-8

Fig. 34 Truck body assembly (sides way)

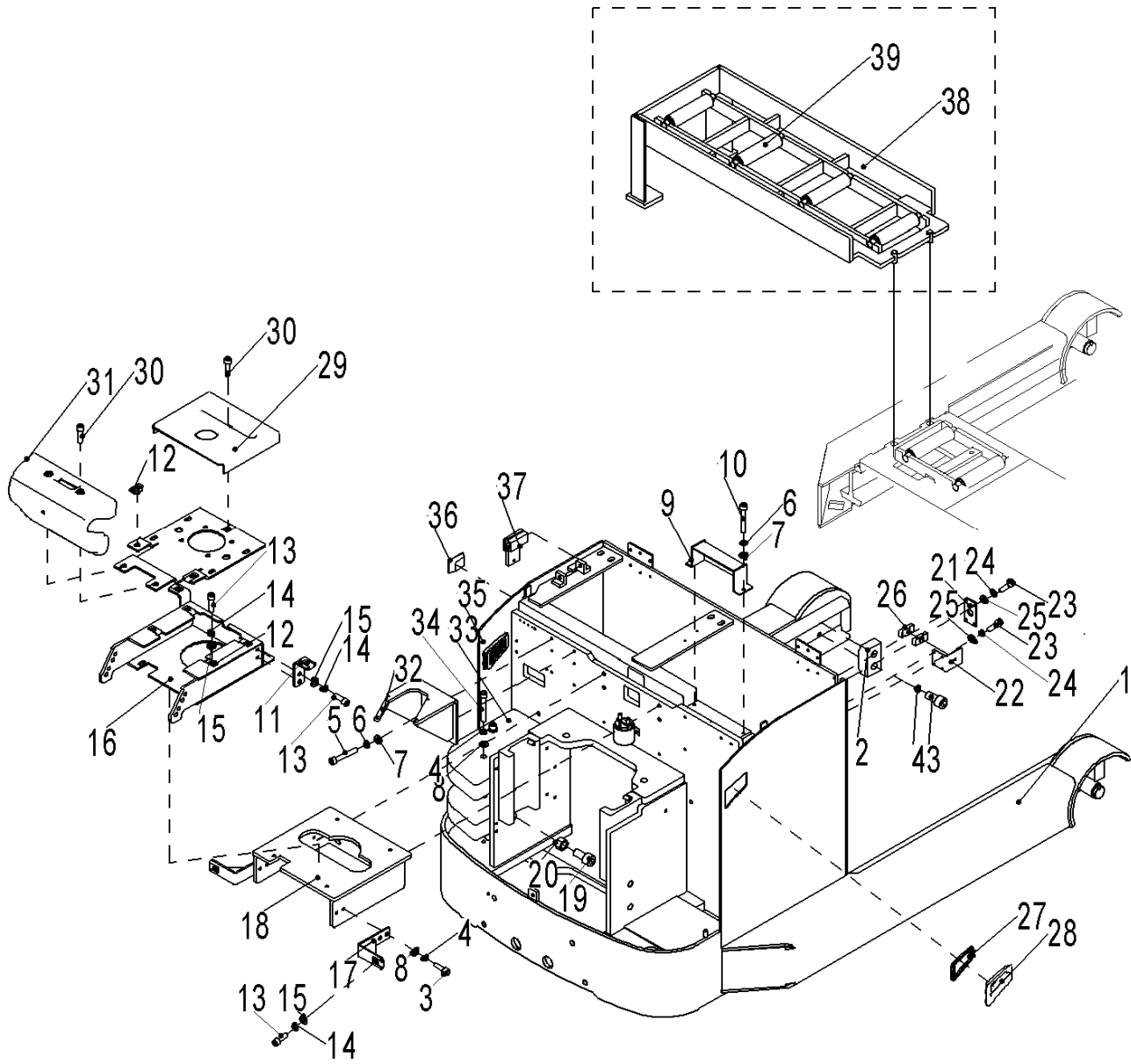

**Fig. 34 Truck Body Assembly (sides way)**

No.	Art No.	Description	Qty.	Note
37	203021510002	Baffle welding (battery)	1	
38	203021510004	Battery replacement frame welding	1	
39	232021510007	Rotary drum	4	

Fig. 35 Hydraulic (three ways)

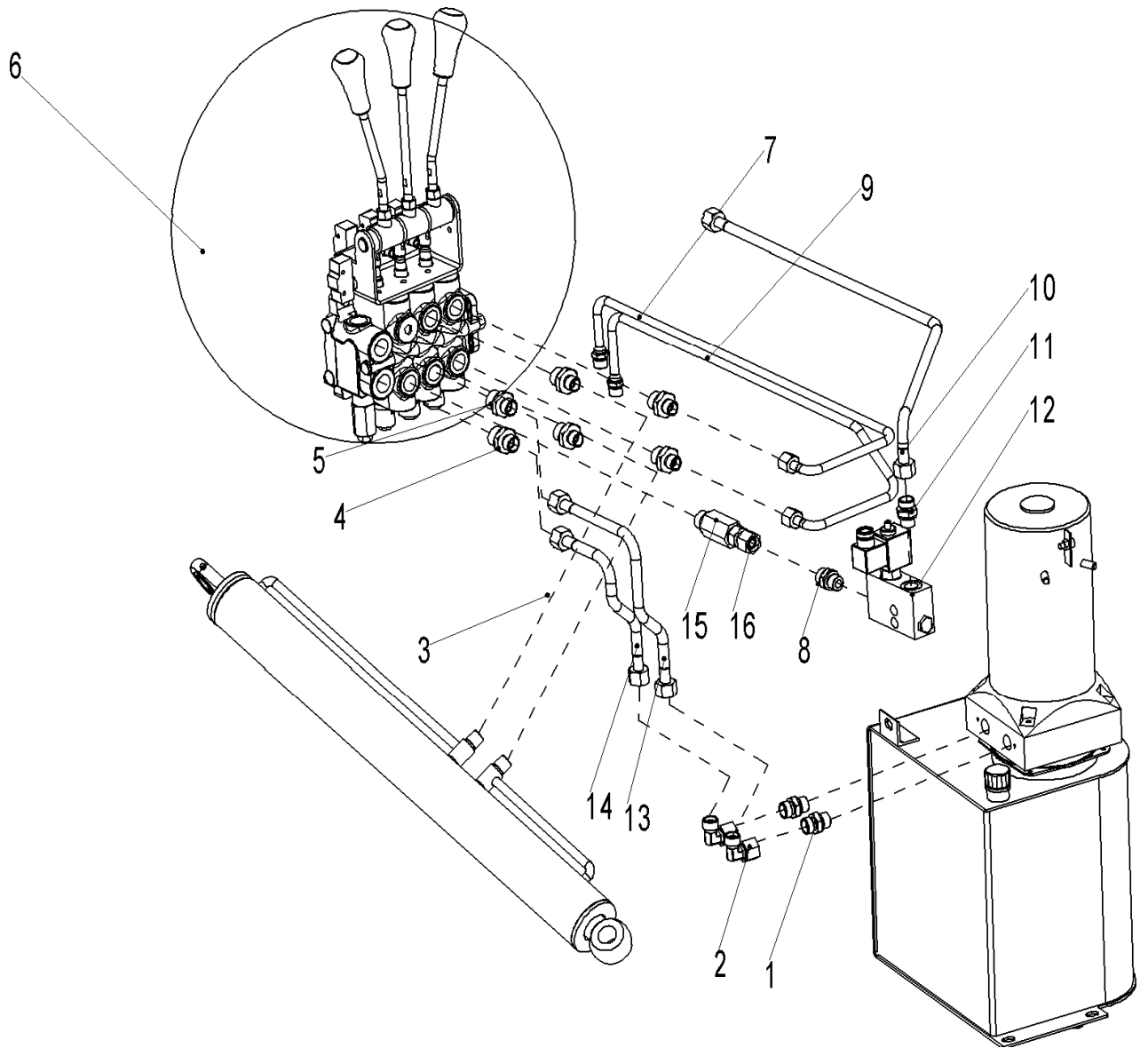

**Fig. 35 Hydraulic (three ways)**

No.	Art No.	Description	Qty.	Note
1	950400300009	Joint (straight)	3	12-G3/8- M18x1.5-24°
2	950400200004	Joint (turning)	2	12-2xM18x1.5-24°
3	201025020016	Hydraulic hose assembly type S (90°)	2	10-L800-ISC-24°
4	950400400005	Joint (straight)	2	12-M22X1.5-M18X1.5-24°
5	950400400012	Joint (straight)	6	10-M20X1.5-M16X1.5-24°
6	201025001001	Multi tandem valve	1	
7	201025020012	Hydraulic pipe welding 4	1	
8	950400100001	Joint (straight)	1	12-G3/8-M18x1.5-24°
9	201025020013	Hydraulic pipe welding 5	1	
10	201025020011	Hydraulic pipe welding 3	1	
11	950400400004	Joint (straight)	1	12-M16X1.5-M18X1.5-24°
12	950700200004	Electromagnetic directional valve	1	VB1601322-100-24D C
13	201025020018	Hydraulic pipe welding 2	1	
14	201025020017	Hydraulic pipe welding 1	1	
15	950600400001	Throttle valve	1	VSC06-10.0L/min
16	201025020010	Multi tandem valve	1	

Fig. 36 Hydraulic (four ways)

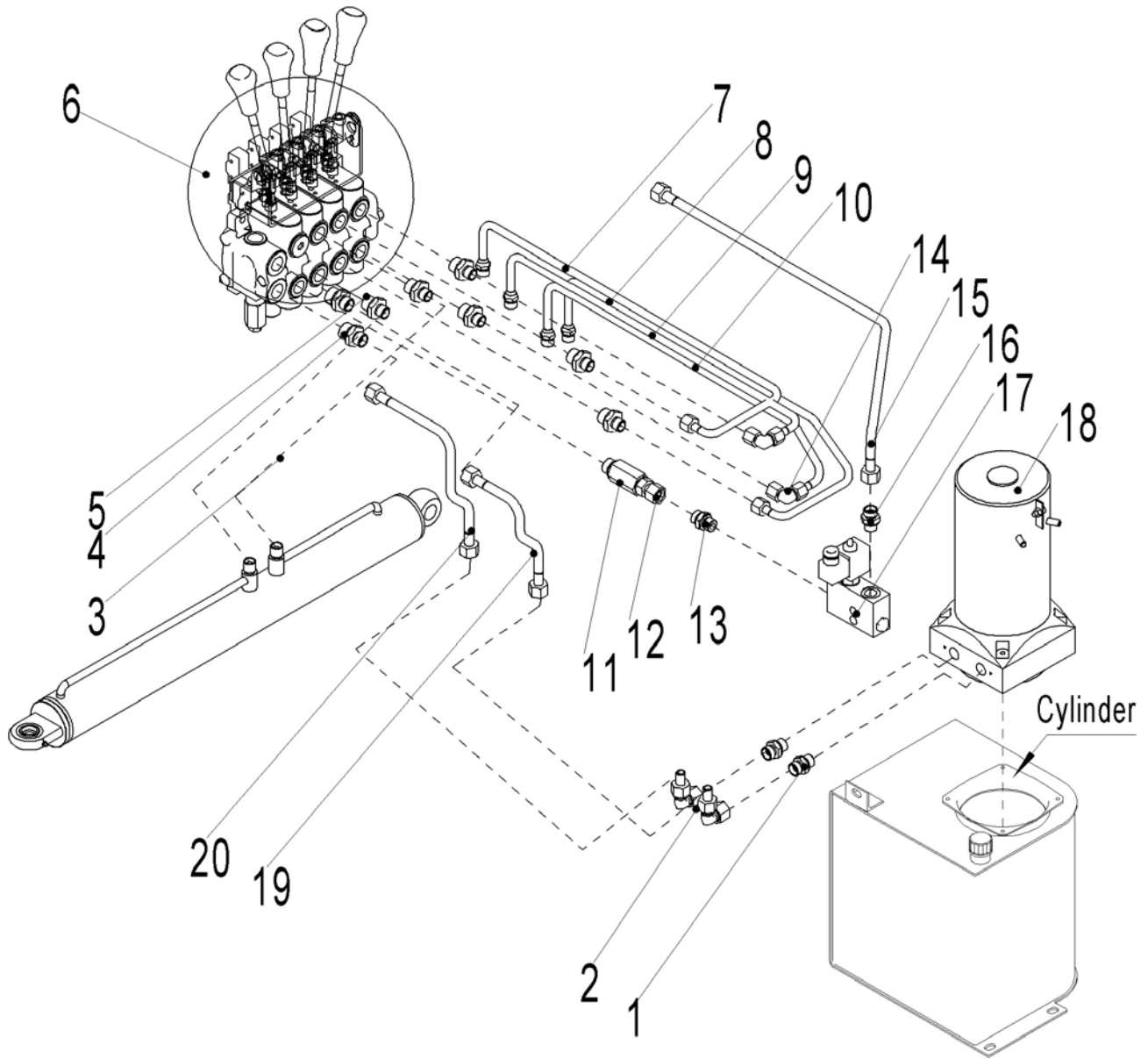
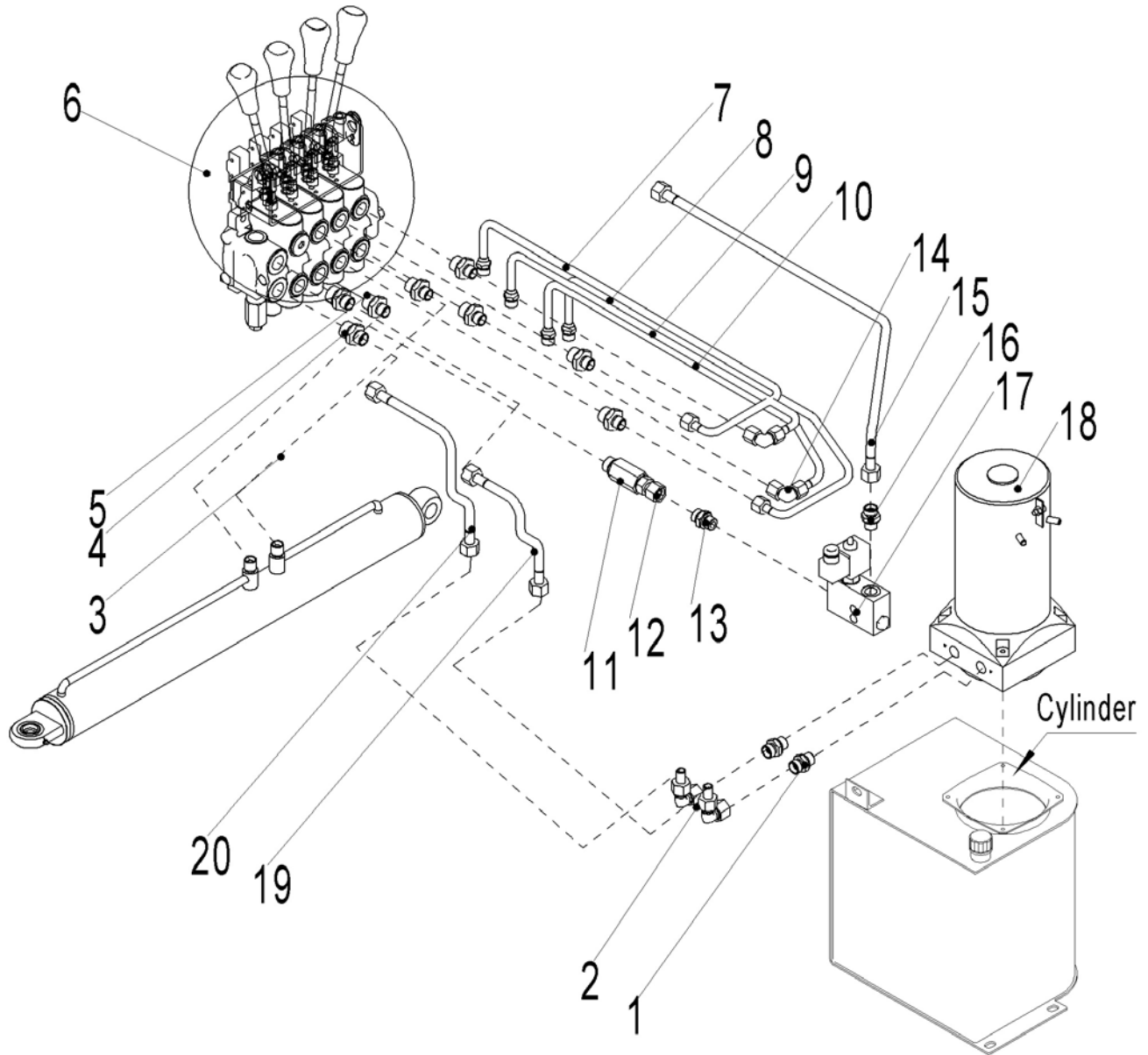

**Fig. 36 Hydraulic (four ways)**

No.	Art No.	Description	Qty.	Note
1	950400300009	Joint (straight)	3	12-G3/8-M18x1.5-24°
2	950400200004	Joint (turning)	2	12-2xM18x1.5-24°
3	201025020016	Hydraulic hose assembly type S (90°)	2	10-L800-ISC-24°
4	95040040005	Joint (straight)	2	12-M22X1.5-M18X1.5-24°
5	950400400012	Joint (straight)	6	10-M20X1.5-M16X1.5-24°
6	201025001001	Multi tandem valve	1	
7	201025020012	Hydraulic pipe welding 4	1	
8	201025020013	Hydraulic pipe welding 5	1	
9	201025520001	Hydraulic pipe welding 2	1	
10	201025520000	Hydraulic pipe welding 1	1	
11	950600400001	Throttle valve	1	VSC06-10.0L/min
12	201025020010	Multi tandem valve	1	
13	950400100001	Joint (straight)	1	)12-G3/8-M18x1.5-24°
14	950400200003	Joint (turning)	2	10-2XM16X1.5-24°
15	201025020011	Hydraulic pipe welding 3	1	
16	950400400004	Joint (straight)	1	12-M16X1.5-M18X1.5-24°
17	950700200004	Electromagnetic directional valve	1	VB1601322-100-24 DC



Fig. 36 Hydraulic (four ways)



**Fig. 36 Hydraulic (four ways)**

No.	Art No.	Description	Qty.	Note
18	950900100003	Hydraulic power unit	1	24V2.2KW2.2cc
	950900100008	Hydraulic power unit	1	24V3.0KW3.2cc
19	201025020018	Hydraulic pipe welding 2	1	
20	201025020017	Hydraulic pipe welding 1	1	

Fig. 37 Forward cylinder

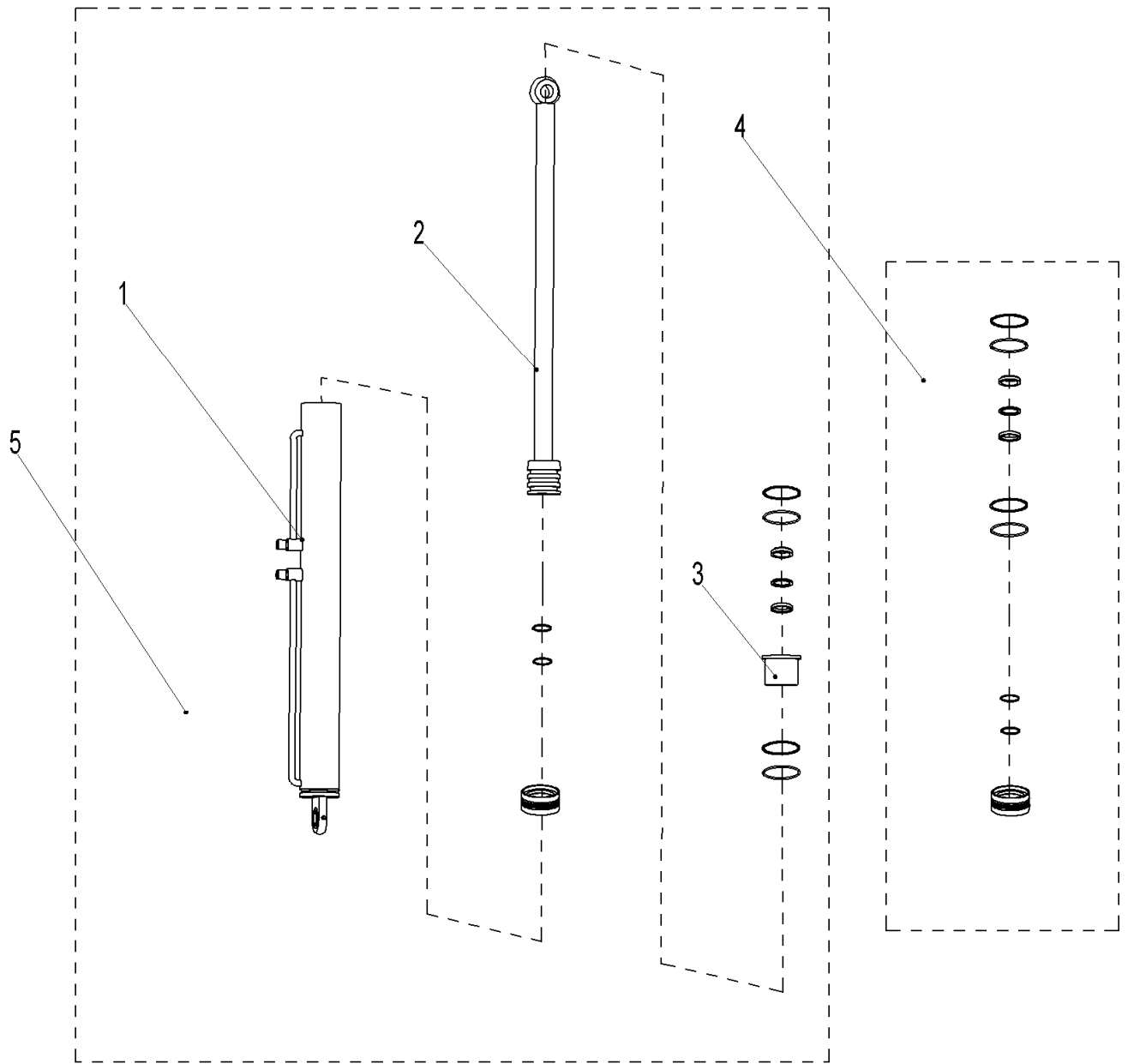

**Fig. 37 Forward Cylinder**

No.	Art No.	Description	Qty.	Note
1	201598520001	Cylinder barrel	1	
2	201598520002	Forward cylinder piston rod	1	
3	201598520003	Forward cylinder cap	1	
4	201598510001	Forward cylinder sealing kits assembly	1	
5	201520010000	Forward cylinder assembly	1	545
	201520010001		1	485

Fig. 38 Front lifting cylinder

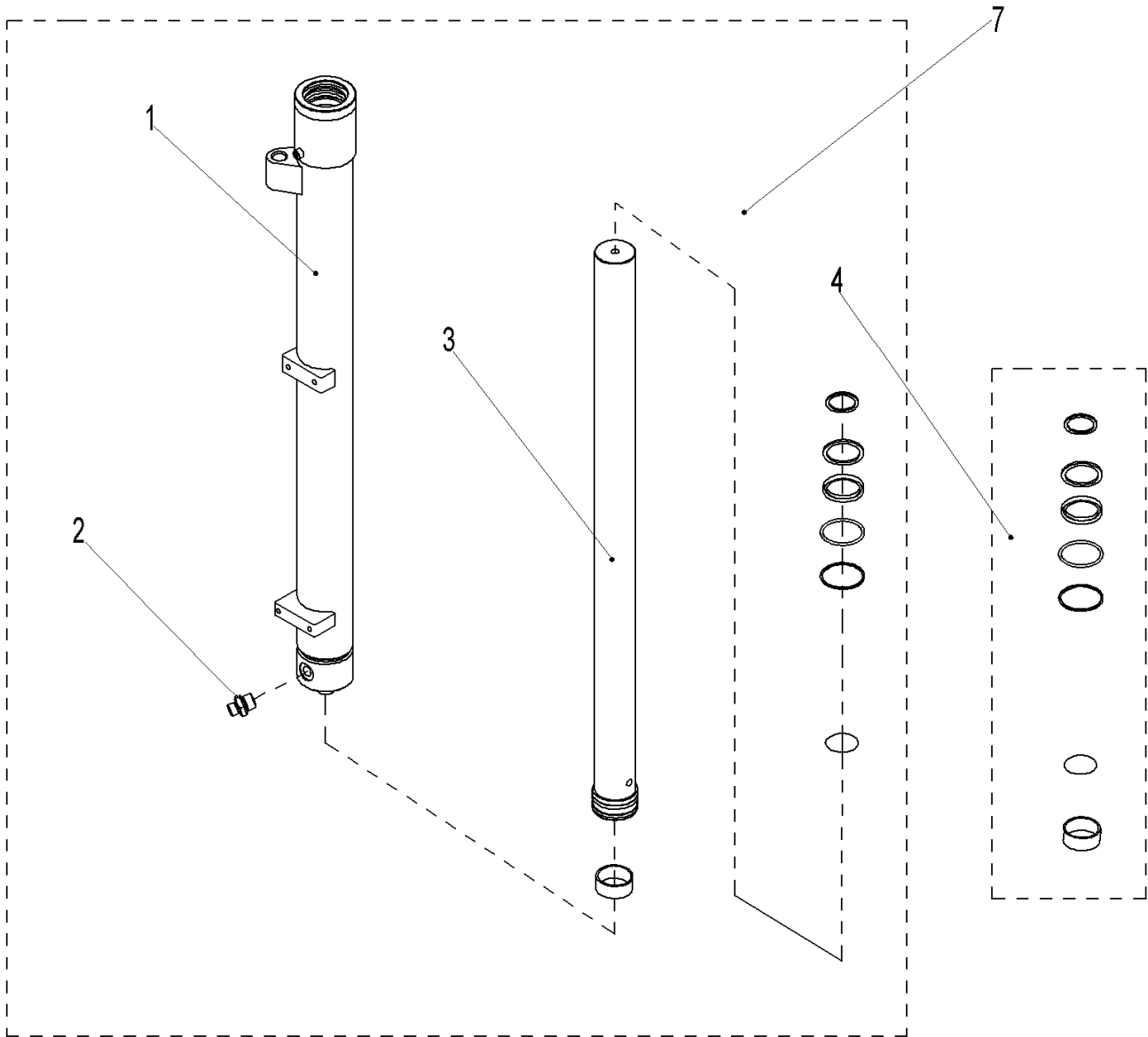

**Fig. 38 Front Lifting Cylinder**

No.	Art No.	Description	Qty.	Note
1	201598520004	Cylinder barrel	1	
2	201598520005	Piston rod	1	
3	201598510002	Sealing pad assembly	1	
4	201598520006	Joint	1	
5	201544502004	Front lifting cylinder assembly	1	

Fig. 39 Rear lifting cylinder

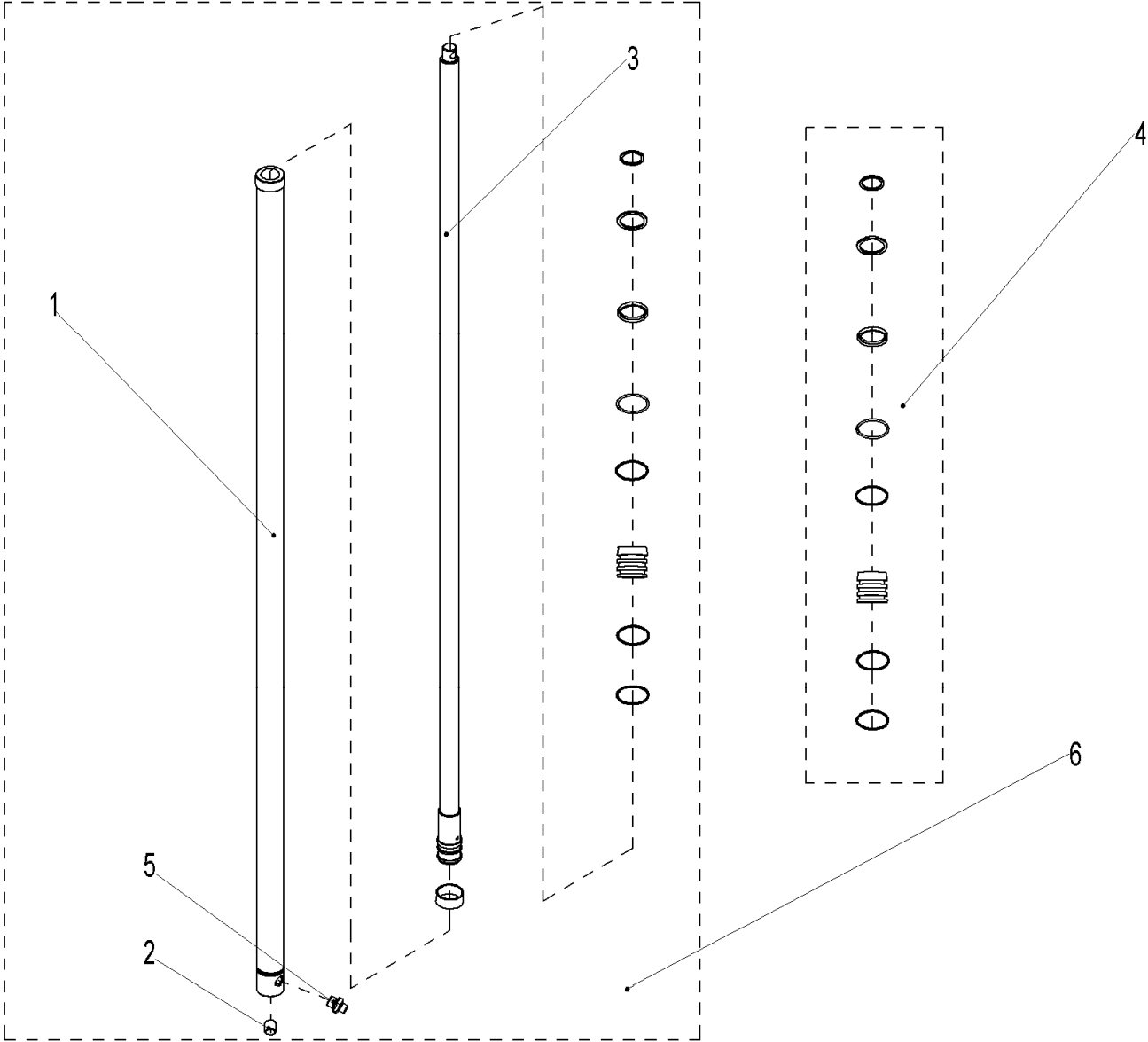
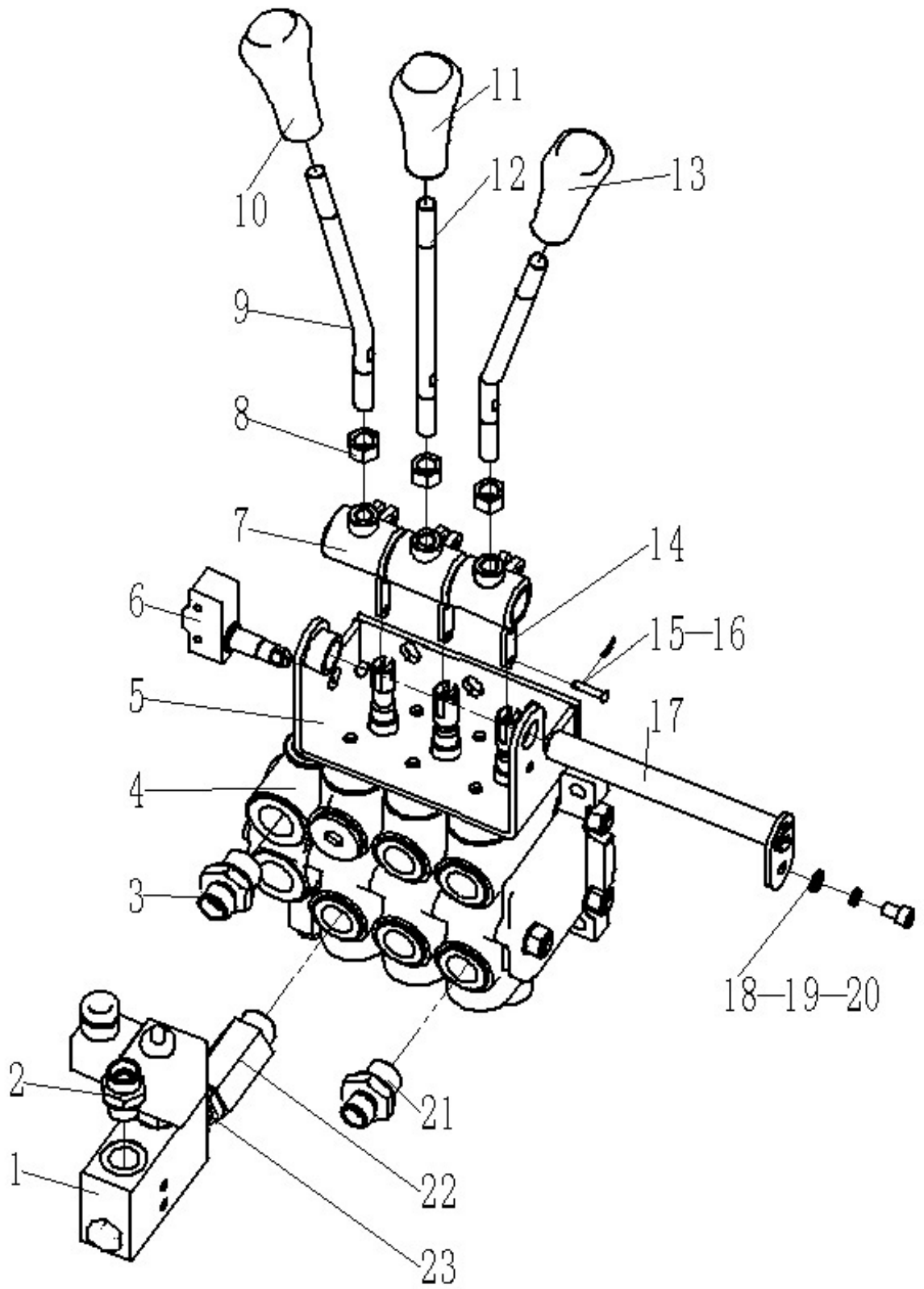

**Fig. 39 Rear Lifting Cylinder**

No.	Art No.	Description	Qty.	Note
1	201598520007	Cylinder barrel	1	
2	201598520008	Cylindrical pin	1	B10×25
3	201598520009	Piston rod	1	
4	201598510003	Sealing pad assembly	1	
5	201598520010	Joint	1	
6	201544502003	Rear lifting cylinder assembly	1	



Fig. 40 Multi tandem valve (three ways)



**Fig. 40 Multi tandem Valve (three ways)**

No.	Art No.	Description	Qty.	Note
1	950700200004	Solenoid valve kits	1	VB1601322-100-24DC
2	950400400004	straight Joint	1	12-M16x1.5-M18x1.5 -24°
3	950400400005	straight Joint	2	12-M22x1.5-M18x1.5 -24°
4	950700100002	Hydraulic multi way control valve	1	
5	201025010000	Multi tandem valve assembly frame welding	1	
6	920200300004	Micro switch RZ-15GQ22-B3	4	
7	201025020003	Multi tandem valve control tiller base	3	
8	910300100007	Nut	3	M10
9	201025020004	Multi tandem valve control lever 1	2	
10	216525020010	Lifting knob	1	
11	216525020011	Forward knob	1	
12	201025020005	Multi tandem valve control lever 2	1	
13	216525020012	Tilt knob	1	
14	201025020008	Metal plate	3	
15	910600700002	Short axle	6	4×18
16	910600600005	Split pin	6	1.6×10
17	201025010001	Multi tandem valve short axle welding	1	
18	910200200033	Screw	1	M6×12

Fig.40 Multi-tandem valve (three ways)

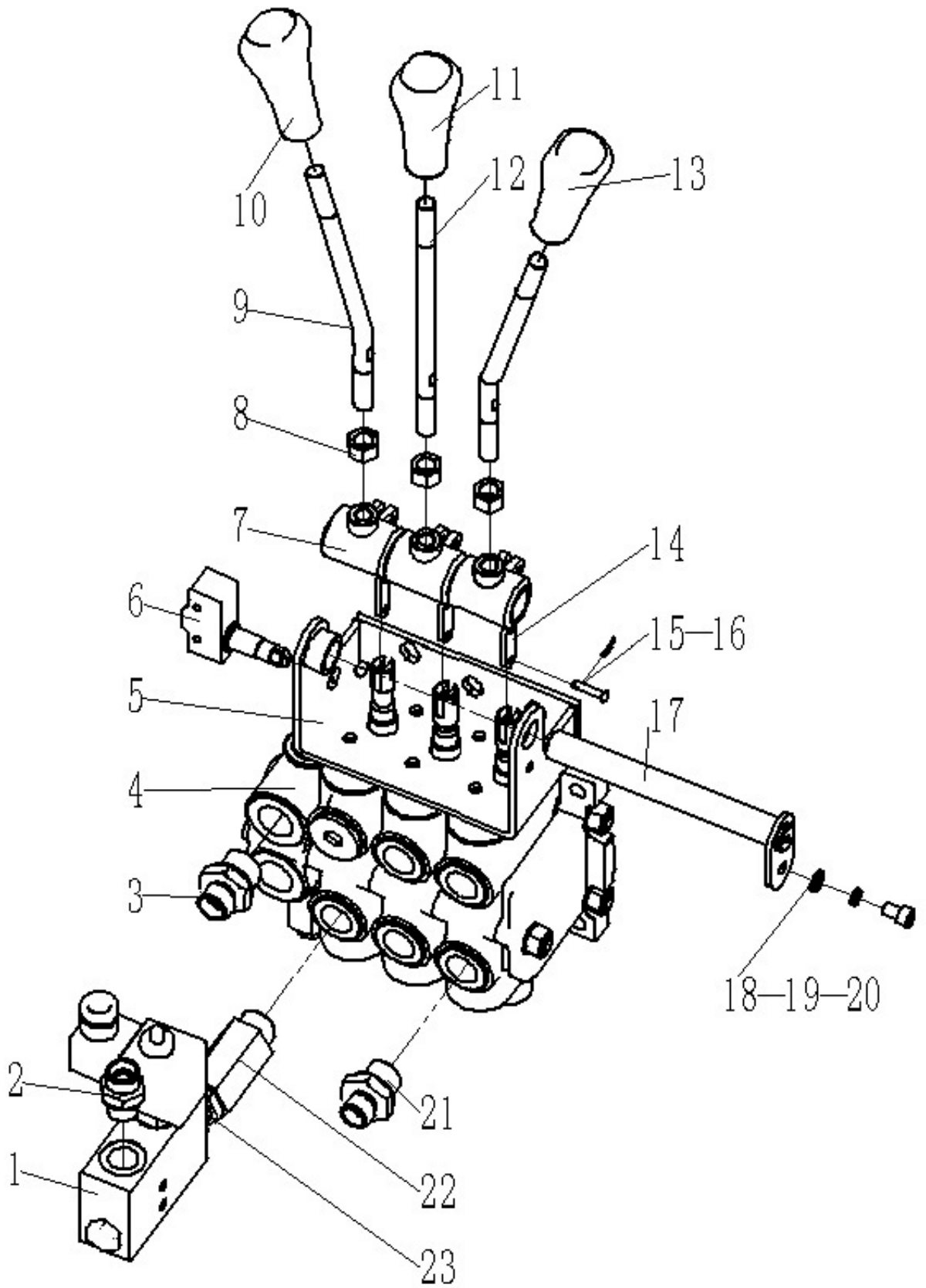

**Fig. 40 Multi tandem valve (three ways)**

No.	Art No.	Description	Qty.	Note
19	910400100005	Flat washer	12	6
20	910400500005	Spring washer	12	6
21	950400400012	Multi tandem valve Joint	6	
22	201025020010	Bushing	1	
23	950400100001	Joint	1	

Fig. 41 Multi tandem valve (four ways)

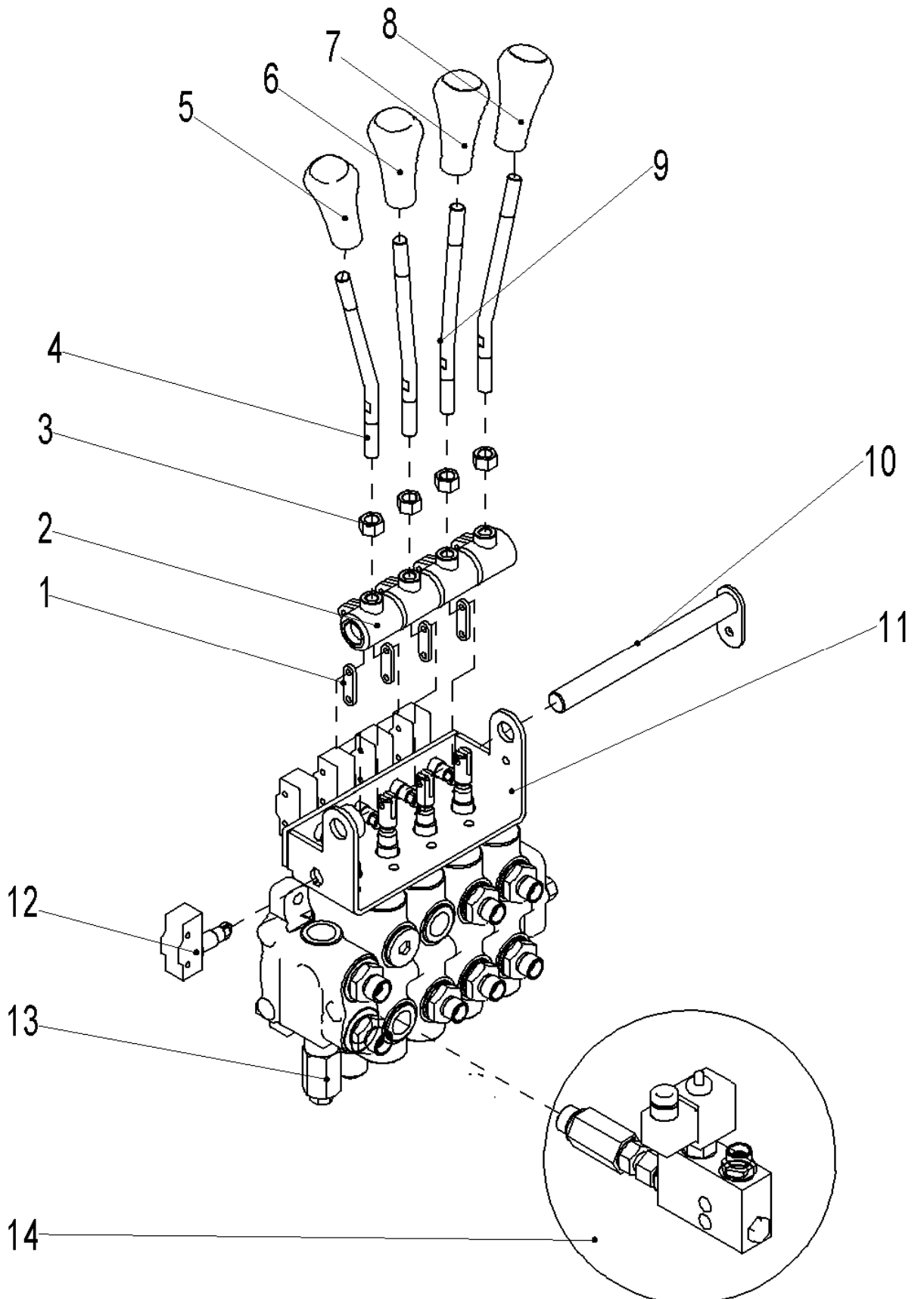

**Fig. 41 Multi Tandem Valve (four ways)**

No.	Art No.	Description	Qty.	Note
1	201025020008	Metal plate	4	
2	201025020003	Multi tandem valve control lever	4	
3	910300100007	Nut	4	GB6170-M10-10
4	201025020004	Control lever 1	2	
5	216525020010	Lifting lever	1	
6	216525020011	Move forward lever	1	
7	216525020012	Tilt lever	1	
8	216525020012	Side shift lever	1	
9	201025520004	Control lever 2	1	
10	201025510001	Axle	1	
11	201025510000	Multi tandem valve assembly frame welding	1	
12	950200300004	Micro switch	5	RZ-15GQ22-B3
13	950700100005	Multi tandem valve four way	1	MSV04-41323-103
14	950700200004	Electromagnetic directional valve	1	VB1601322-100-24 DC

Fig. 42 Pump system 2.2kW

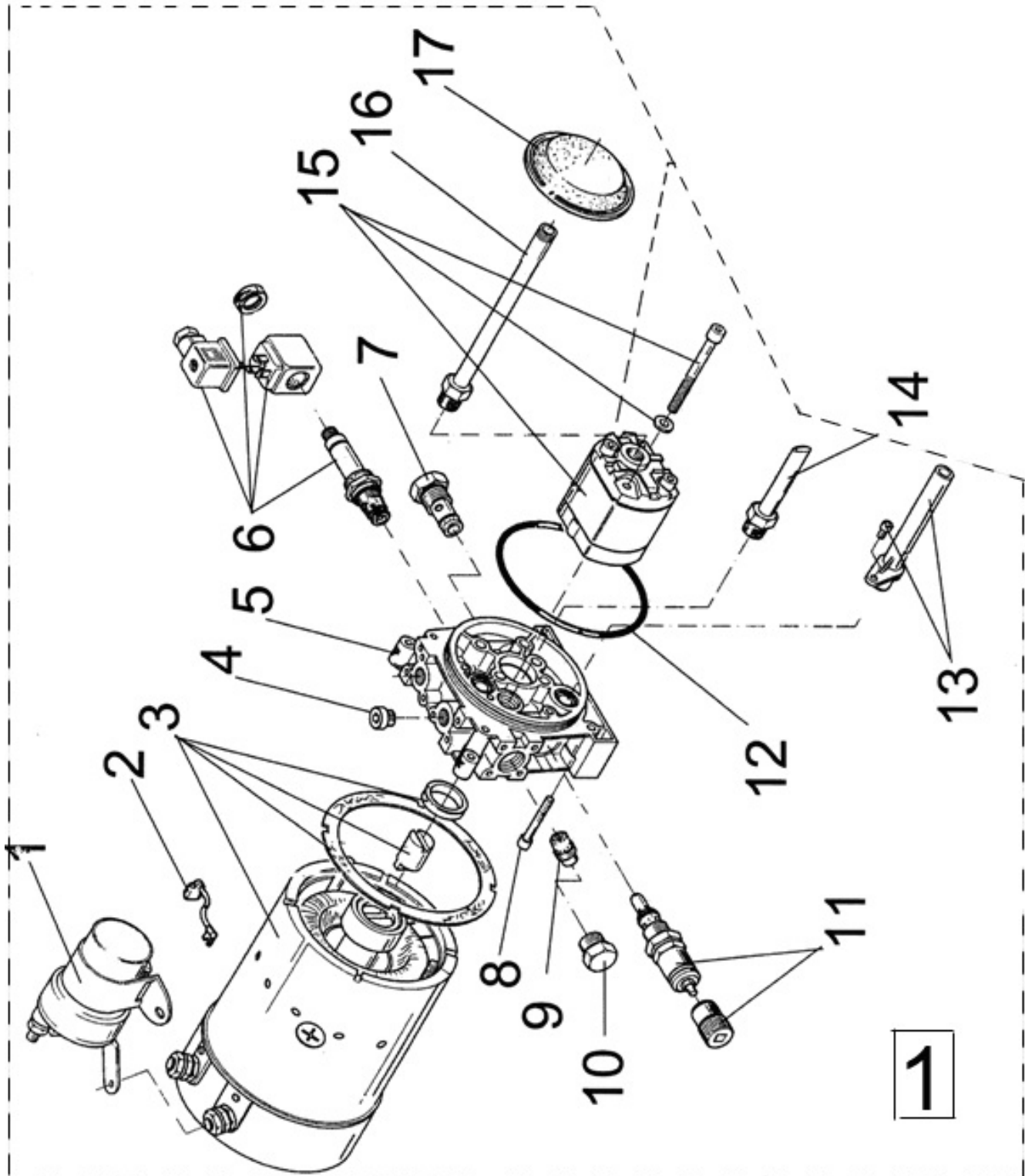
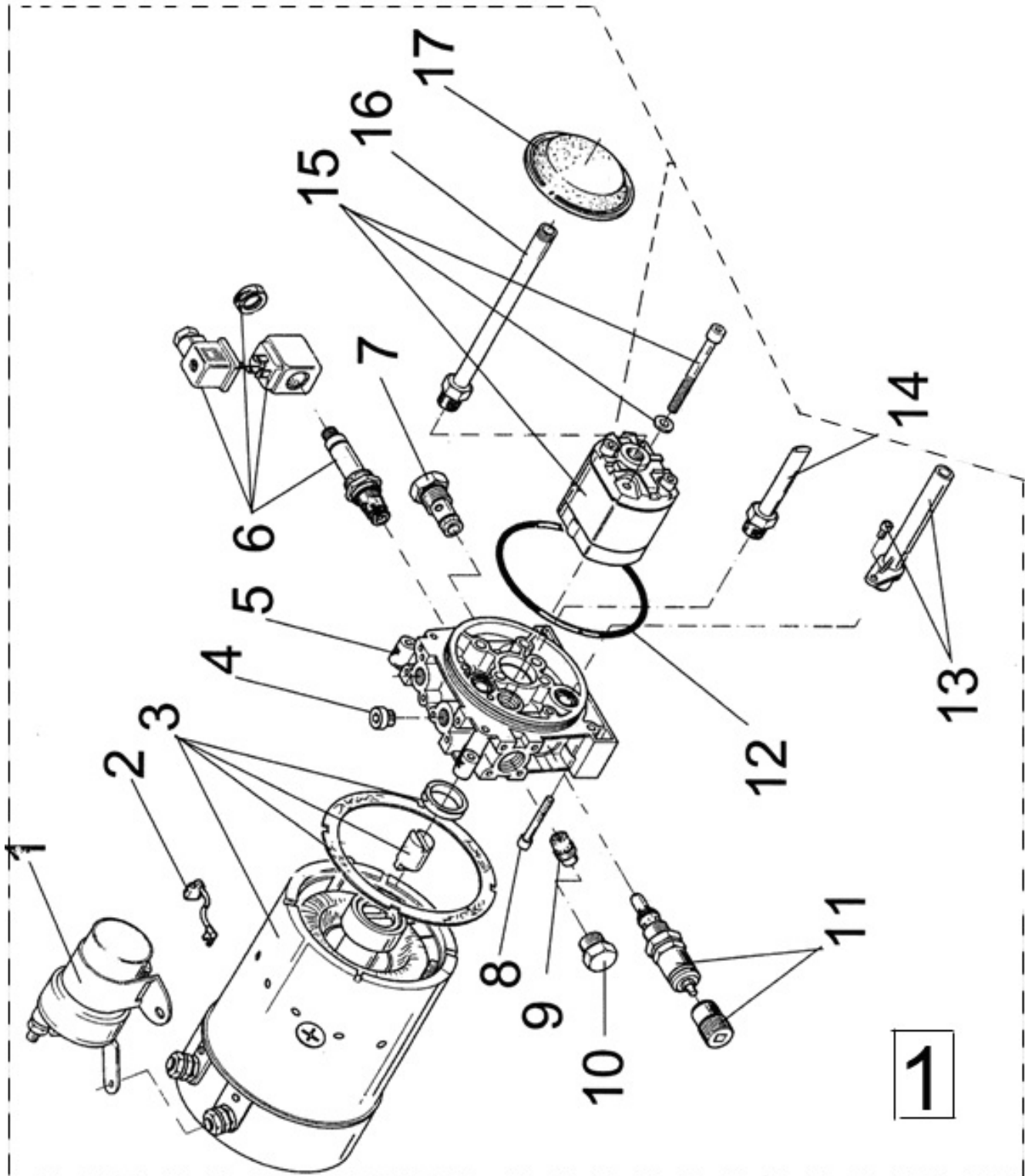

**Fig. 44 Pump system2.2kW**

No.	Art No.	Description	Qty.	Note
1	201098520097	Pump contactor	1	24V120A
2	201098520098	Carbon brush(assembly)	1	
3	201098520099	Motor	1	
4	201098520100	Plug	1	
5	201098520101	Valve body	1	
6	201098520102	Solenoid valve	1	
7	201098520103	Check valve	1	
8	201098520088	Screw	4	
9	201098520104	Flow control valve	1	7.5L/min
10	201098520105	Bolt	1	
11	201098520106	Overflow valve	1	
12	201098520091	O ring	1	
13	201098520107	Oil return pipe	1	
14	201098520108	Oil return pipe	1	
15	201098520109	Gear pump	1	2.2cc/r
16	201098520110	Oil suction pipe	1	
17	201098520111	Filter	1	
1	950900100003	DC power unit	1	24V3.0kW3.2cc/r



Fig. 43 Pump system 3.0kW



**Fig. 43 Pump system3.0kW**

No.	Art No.	Description	Qty.	Note
1	201098520081	Pump contactor	1	24V150A
2	201098520082	Carbon brush(assembly)	1	
3	201098520083	Motor	1	
4	201098520084	Plug	1	
5	201098520085	Valve body	1	
6	201098520086	Solenoid valve	1	
7	201098520087	Check valve	1	
8	201098520088	Screw	4	
9	950600400003	Flow control valve	1	7.5L/min
10	201098520089	Bolt	1	
11	201098520090	Overflow valve	1	
12	201098520091	O ring	1	
13	201098520092	Oil return pipe	1	
14	201098520093	Oil return pipe	1	
15	201098520094	Gear pump	1	3.2cc/r
16	201098520095	Oil suction pipe	1	L=250.50mm
17	201098520096	Filter	1	
1	950900100008	DC power unit	1	24V3.0kW3.2cc/r

**Fig. 44 Battery**

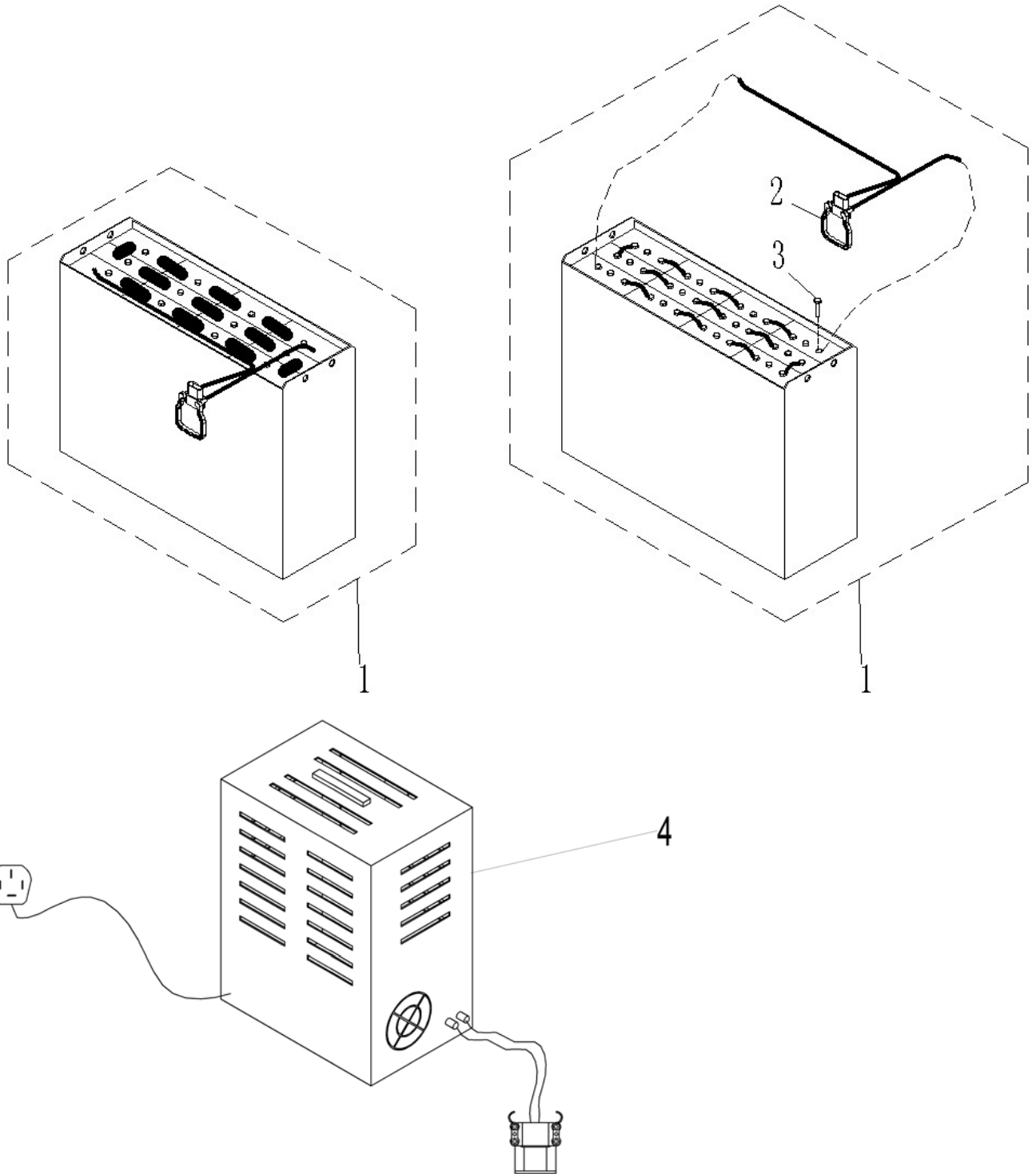

**Fig. 44 Battery**

No.	Art No.	Description	Qty.	Note
1	206037010002	Power supply assembly	1	24V400Ah
	201037010000			24V270Ah
	201037010003			24V360Ah
2	920400100007	Plug kits	1	REMA95311-00
3	505698510002	Screw	24	Only bolt type battery
4	921000200183	Charger SN24V35A	1	
5	921000200184	Charger SN24V35A	1	
6	921000200185	Charger SN24V35A	1	
7	921000200186	Charger SN24V35A	1	
8	921000200187	Charger SN24V35A	1	
9	921000200188	Charger SN24V35A	1	
10	921000200025	Charger SN24V55A	1	
11	921000200026	Charger SN24V55A	1	
12	921000200027	Charger SN24V55A	1	
13	921000200028	Charger SN24V55A	1	
14	921000200029	Charger SN24V55A	1	
15	921000200030	Charger SN24V55A	1	

Fig. 45 Controller components

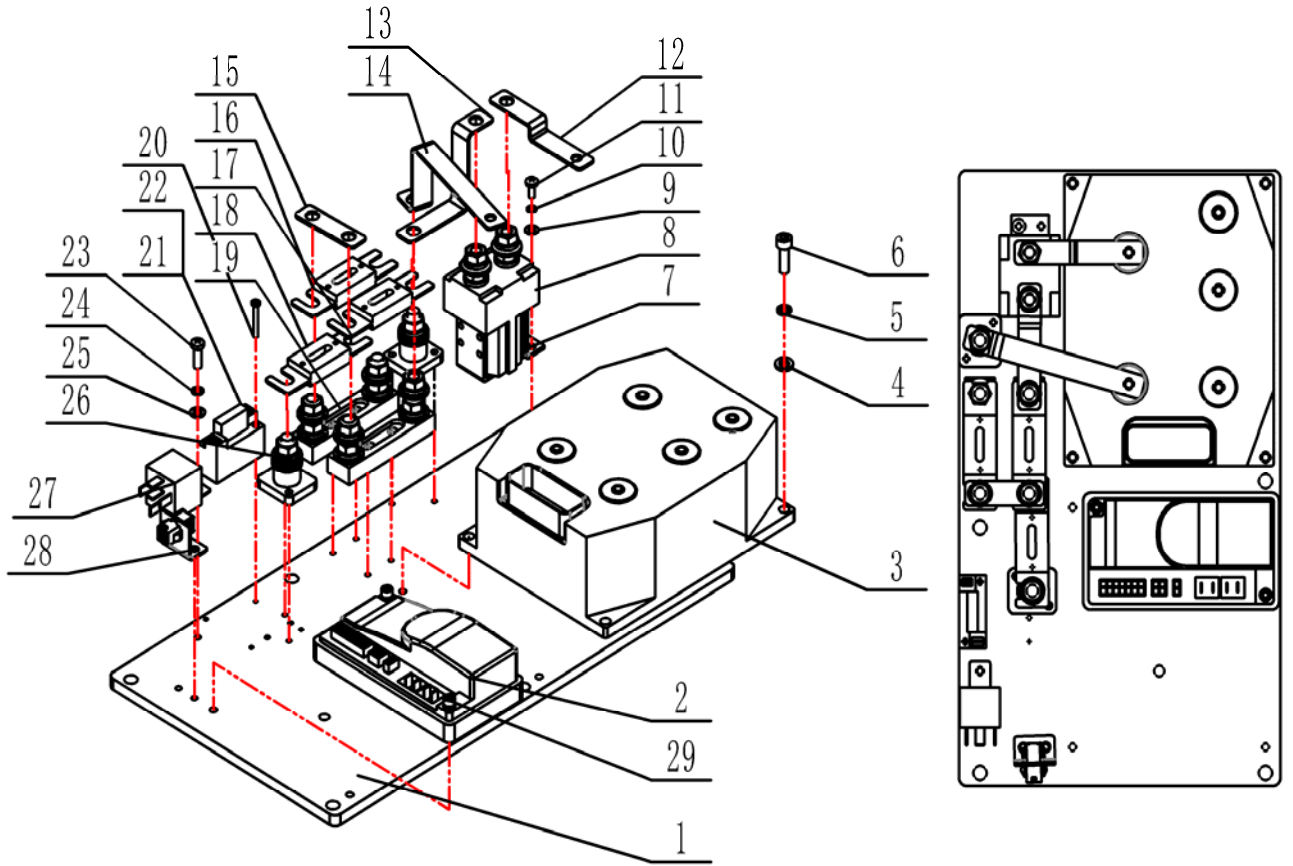

**Fig. 45 Controller components**

No.	Art No.	Description	Qty.	Note
1	201033020000	Aluminium plate	1	
2	921400100023	Controller	1	1220C-2201
3	921400100005	Controller	1	1232E-2321
4	910400100005	Flat washer	4	GB97.1-6-200HV
5	910400500005	Spring washer	4	GB93-6
6	910200200035	Screw	4	GB70.1-M6x16-8.8
7	921300400001	Mai contactor fixing part	1	(100)
8	920700100004	Contactor	1	DC24V-C100-120
9	910400100003	Flat washer	8	GB97.1-4-200HV
10	910400500003	Spring washer	8	GB93-4
11	910200500021	Screw	8	GB818-M4x10-4.8
12	201033020001	Copper bar 一	1	
13	201033020002	Copper bar 二	1	
14	201033020003	Copper bar 三	1	
15	505633020003	Copper bar	1	
16	920100100008	Fuse	1	200A(plastic)
17	920100100007	Fuse	1	150A(plastic)
18	920100100001	Fuse	1	30A(plastic)

Fig. 45 Controller components

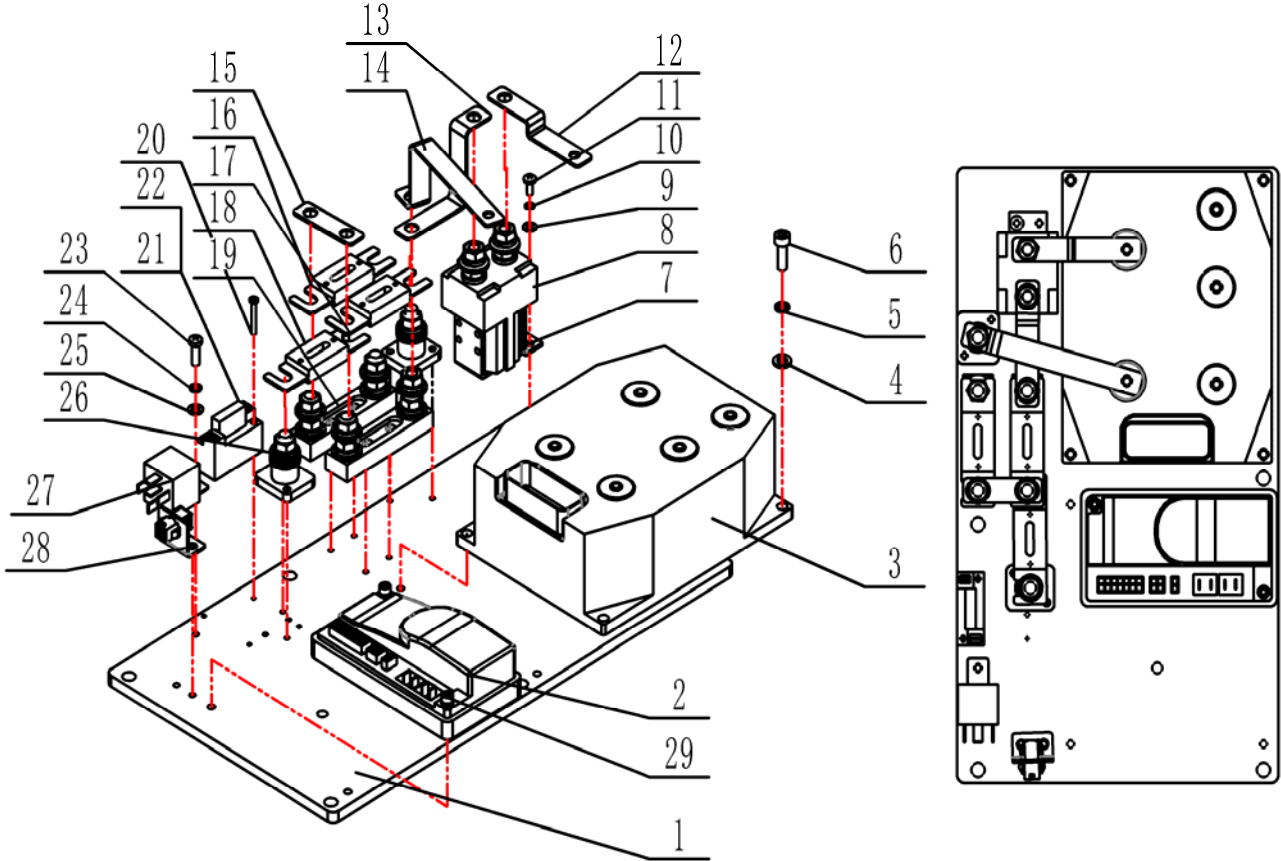
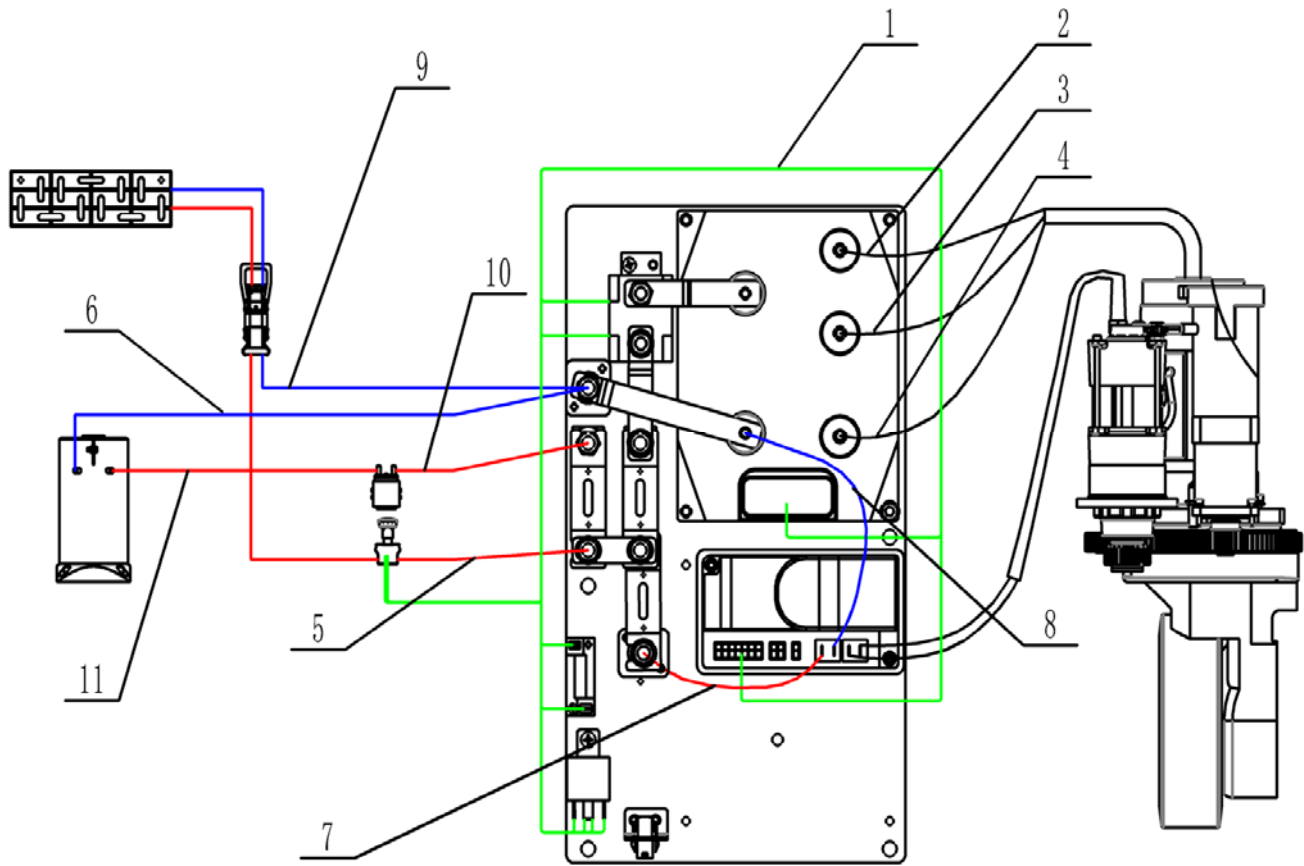

**Fig. 45 Controller components**

No.	Art No.	Description	Qty.	Note
19	920100400002	Fuse seat	2	SY Y
20	910200500016	Screw	2	GB818-M3x25-4.8
21	920100400006	Fuse seat	1	BD-1x10A
22	920100200002	Fuse	1	10A
23	910200500037	Screw	1	GB818-M5x10-4.8
24	910400500004	Spring washer	1	GB93-5
25	910400100004	Flat washer	1	GB97.1-5-200HV
26	920100400001	Fuse seat	1	M8
27	920800100001	Relay	1	DC24V-ACR01F-F-1C
28	921300300003	Plug fixing frame 4 pins	1	
29	910200500027	Screw	2	GB818-M4x25-4.8



Fig. 46 Wiring harness



**Fig. 46 Wiring harness**

No.	Art No.	Description	Qty.	Note
1	201033010027	Main control wiring harness	1	(1232E-2321+1220 C)
2	201033010001	Cable	1	-UT-16-6-8-500
3	201033010002	Cable	1	-VT-16-6-8-500
4	201033010003	Cable	1	-WT-16-6-8-500
5	201033010004	Cable	1	-B0+-25-8-8-520
6	201033010005	Cable	1	-B2--25-8-8-950
7	201033010029	Linking cable	1	-B6+-6-6.3-8-300
8	201033010030	Linking cable	1	-B3--6-6.3-6-350
9	201033010011	Main power supply wiring harness	1	(1232E-2121+EPS1 220 Better)
10	201033010014	Cable	1	-B5+-25-8-8-350
11	201033010015	Cable	1	-B8+-25-8-8-600

### Easy worn parts list

No.	Art No.	Fig./Position	Description	Qty.	Note
1	201538020020	Fig.9/15	Axle	1	Fork frame kits
2	940500400002	Fig.9/14	Bearing	4	
3	910700200023	Fig.25/1	Bearing	2	Load roller
4	940300300024	Fig.25/2	Front wheel	1	
5	201017001000	Fig.25/ I	Load roller assembly	2	
6	940300300019	Fig.31/12	Balance wheel	1	Steering wheel kits
7	910700200019	Fig.31/11	Bearing	2	
8	532616520003	Fig.31/9	Bushing	1	
9	532616520001	Fig.31/4	Spacer	1	
10	910700400004	Fig.31/3	Bearing	2	
11	940200100006	Fig.12/8	Main roller	4	Mast kits
12	940200200007	Fig.12/4	Side roller	4	
13	940200500001	Fig.14/1	Chain wheel bearing	2	
14	940200300012	Fig.16/23	Compound roller	2	
15	940801300001	Fig.30/4	Hinge kits	2	Battery cover turning structure
16	940200100011	Fig.23/15	Main roller	4	Drive assembly
17	201598510003	Fig.39/4	Sealing pad assembly	1	Rear lifting cylinder
18	201598510002	Fig.38/3	Sealing pad assembly	1	Front lifting cylinder

### Easy worn parts list

No.	Art No.	Fig./Position	Description	Qty.	Note
19	201598510001	Fig.37/4	Forward cylinder seal kits assembly	1	Forward cylinder
20	201598510004	Fig.32/4	Tilt cylinder seal kits assembly	1	Tilt cylinder
21	940500200002	Fig.26/8	Bushing with shoulder	2	Tiller kits
22	940400100002	Fig.26/13	Air spring (S≥55)	1	
23	940400100006	Fig.28/5	Air spring	1	Protective arm assembly
24	505617510005	Fig.28/8	Spring	1	
25	940500200008	Fig.29/3	Bushing with shoulder	4	Platform assembly
26	940400100008	Fig.29/6	Air spring	1	
27	920400100007	Fig.44/2	Plug kits	1	Battery
28	505698510002	Fig.44/3	Screw	24	