

Instruction Manual

ELECTRIC HIGH LIFT TRUCK



Note: Owner/Operator must read and understand this instruction manual before using the electric high lift truck.

THANK YOU VERY MUCH FOR SELECTING OUR ELECTRIC HIGH LIFT TRUCK. THIS INSTRUCTION MANUAL DESCRIBES CORRECT OPERATING METHOD TO ENSURE PROLONGED SERVICE LIFE. PLEASE READ AND COMPLETELY UNDERSTAND THIS MANUAL BEFORE OPERATING THE LIFT TABLE. ALWAYS KEEP THIS MANUAL AT AN APPROPRIATE PLACE. IF THE MANUAL OR WARNING DECAL IS MISSING, PLEASE CONTACT WITH OUR DEALER.

Brief Introduction

DGB series electric high lift trucks (short for DGB series hereafter) are designed on the basis of hand-operated high lift pallet truck (short for HLT hereafter). It has equipped with battery powered Pump Station, high-pressure hose and electrical control device.

It is featured by automatic pumping up and down. Thus, it can greatly release laboring and raise working efficiency. Meanwhile, it has kept the features of HLT, such as the application of material lifting and transporting when the fork is on its low position, and the use as a working table when the fork on its highest position.

Those features make HLT series become a most popular tool in the field of workshop and warehouse as working table, or loading and unloading table for mini-truck, and transporting tool.

Mechanical part of DGB series consists of fork, lifting yoke, lifting bar, cylinder, handle and etc.

Its power part includes battery, mini-pump station, high-pressure hose, fuse, control switch and etc.

It is easy to operate by pushing button (Part No.197X) on the top of Handle (102X) to pump the goods up and down. It can be stopped at any position as you like.

Specifications

Model	DGB1-520	DGB1-680	DGB11/2-520	DGB11/2-680
Rated Capacity (kgs)	1000		1500	
Max. Lifting Height (mm)	800			
Min. Fork Height (mm)	85			
Fork Length (mm)	1140		1100	
Fork Overall Width (mm)	520	680	520	680
Dia. of Front Wheel (mm)	$\Phi 75 \times 50$			
Dia. of Rear Wheel (mm)	$\Phi 150 \times 40$			
Motor Working Voltage	12V			
Battery	66Ah/12V			
Charger	10A/12V			
Net Weight (kgs)	140	147	149	157

Assembly and Adjustment

1. Taking the packing materials away carefully. Don't damage the pallet truck.
2. Insert handle (102X) into the socket of cylinder (160); lock it with pin (108) and 2 snap ring (109). Swing the handle up and down to see if it moves freely. Finally put on spring (105).
3. Open the electrical control case by removing the cover (255). Insert switch wire and plug (184) hanging down from handle (102) into socket (221) in the case. Insert two fuses of 5 Amp (277) into two sockets of $F_1 \setminus F_2$.
4. Check the electrical device and elements in the case to see if they are lose, drop down or break.
5. Check oil pipes in the hydraulic system to see if they are screwed tightly.
Open cover (217) to see if oil is sufficient.1
6. Push Up-button (197X)  on the top of handle (102X) intermittently

to lift the fork, meanwhile to observe electrical device and elements in the case to see if there's any abnormal phenomenon. If there's no, continue to push the Up-button to lift the fork to its highest position. Then push Down-Button (197X)↓ to release the fork to its lowest position steadily.

7. Repeat the above procedure for 3 to 4 times to its full travel in order to release possible air in the hydraulic system and to check if there're any other problems.
8. Close the case with cover (255) and screw it tightly with screw (256).

Operation

1. DGB series are designed for working on the flat and even ground.
2. Handle (102X) is used for pulling and steering.
3. When the fork is lifted to its highest position, DGB series should not be moved.
4. Push Up-button, the fork goes up. Stop pushing, the fork can stop at any position and won't slide down.
5. Push Down-button, the fork goes down. Stop pushing, the fork can stop at any position and won't slide down.
6. As a safety valve is set in the pump station, when DGB series lifts a load of 1000kgs (its full capacity), only mid-cylinder (413) can extend out fully, while the piston rod (406) cannot extract out to prevent overload.
7. Recharge Battery (254) when the lifting speed is remarkably slow. There only three red (LBD) lighting in the electric volume gauge (283). To plug recharger (271) into a power socket. Make sure your local power matches the recharger. Then connect the recharger to Socket (225) in the electrical control case. The battery will be automatically recharged. In the meantime the yellow (LBD) lights. Recharging usually takes 4 to 5 hours.

Precautions

1. Read the manual carefully before operation. Finish every procedure as required in the manual.
2. Lifting the fork to its full range 1 to 2 times before use to release the air in the hydraulic system.
3. DGB series are prohibited to lift or pull person. The DGB series are not allowed to work on the slope.
4. Don't put your hand or foot under the fork or on the moving surface of piston rod (406) and mid-cylinder (413).
5. Put the load on the centre of the forks. Eccentric loading is strictly prohibited.
6. The safety valve in the pump station will be automatically open when it is overloaded. Under such circumstance, don't push up-button. Otherwise that will reduce the lifetime of the pump station.
7. To replace or fill hydraulic oil, the forks should be lowed to the lowest position. The oil to be used should be clean. The oil condensation point should be $\leq - 20^{\circ}\text{C}$. The motion viscosity: 20-30 cst (centistokes).

Easy-worn Parts

Series No.	Part No.	Description	Quantity
1	277	5A	1

Problems and Maintenance

NO.	Symptom	Cause	Remedy
1	Fork does not lift up when pushing up-button	1. Switch is out of order 2. Fuse is broken 3. Magnetic switch is out of order 4. Oil not enough	1. Check switch (197X) 2. Replace fuse (277) 3. Check magnetic switch (224) 4. Fill oil
2	Fork does not descend when pushing down-button	1. Switch is out of order 2. Fuse broken 3. Magnetic switch is out of order 4. Object blocking	1. Check switch (197X) 2. Replace fuse (277) 3. Check magnetic switch 4. Check and remove the object
3	Fork does not lift to highest position	1. Oil not enough	1. Fill oil
4	Motor does not work	1. Motor broken 2. Terminals and inserters are loose 3. Battery worn out	1. Check motor brush 2. Check terminals and inserters 3. Recharging at once
5	Battery has no enough power	1. Recharging time is not enough 2. Battery is out of order	1. Recharge for a longer time 2. Fill battery liquid or replace battery
6	Oil leakage from Piston Rod & Mid-cylinder	1. Oil seals broken	1. Replace oil seals
7	Unsteady when DGB1 is on its highest position	1. The ground is not flat or even 2. Centrifugal axle is left from the ground	1. Work on flat and even ground 2. Adjusting centrifugal axle (7) to touch the ground

HYDRAULIC CIRCUIT / ELECTRIC WIRING

DIAGRAM

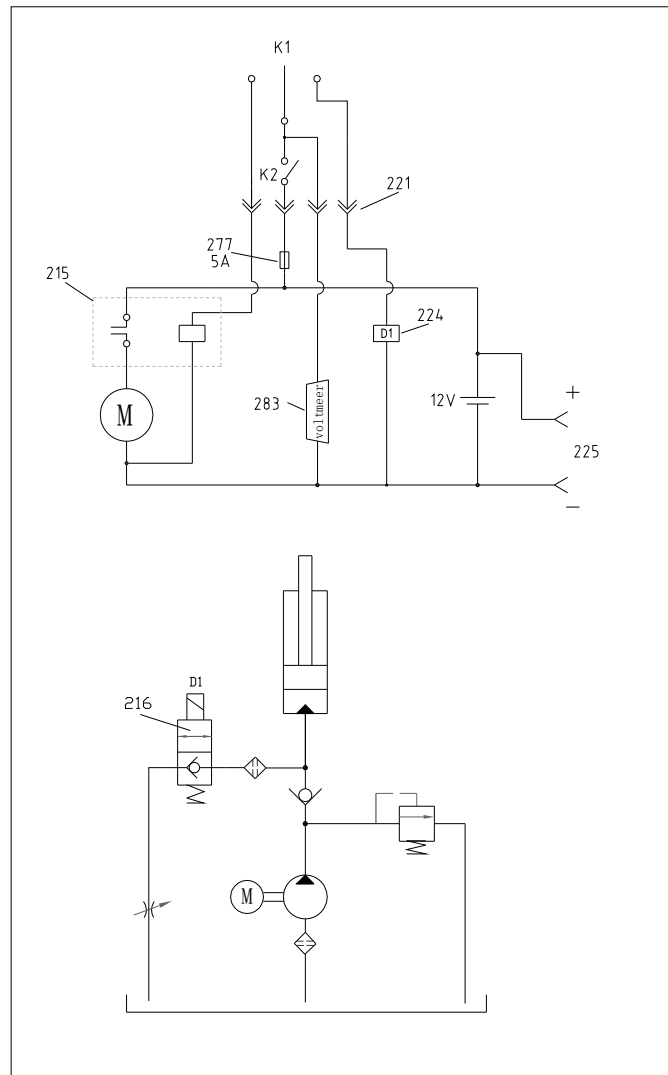

EXPLODED FIGURE & PARTS LIST

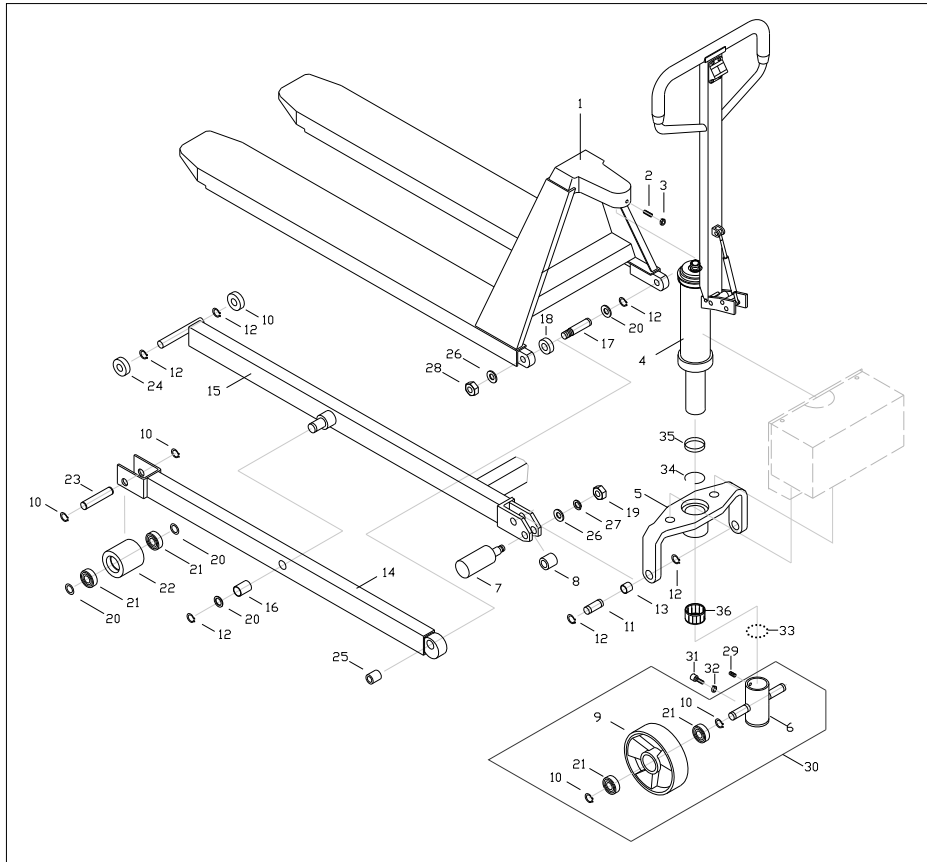

Item No.	Description	Q'ty
1	Fork	1
2	Screw	1
3	Nut	1

4	Power Unit	1
5	Hold Yoke	1
6	Wheel Yoke	1
7	Centrifugal Axle	2
8	Spacer	2
9	Steering Wheel	2
10	Snap Ring	8
11	Pin	2
12	Snap Ring	12
13	Bush	2
14	Leg	2
15	Leg	1
16	Bush	2
17	Pin	2
18	Washer	2
19	Nut	2
20	washer	8
21	Ball bearing	8
22	Front wheel	2
23	Wheel axle	2
24	Roller	4
25	Bush	2
26	Washer	4
27	Spring washer	2
28	Lock Nut	2
29	Screw	1
30	Steering wheel assembly (incls.6,9,10,21)	1
31	Screw	1
32	Nut	1
33	Ball	43

34	Snap ring	1
35	Bush	1
36	Needle Bearing	1

EXPLODED FIGURE & PARTS LIST OF ELECTRIC CONTROL ASSEMBLY

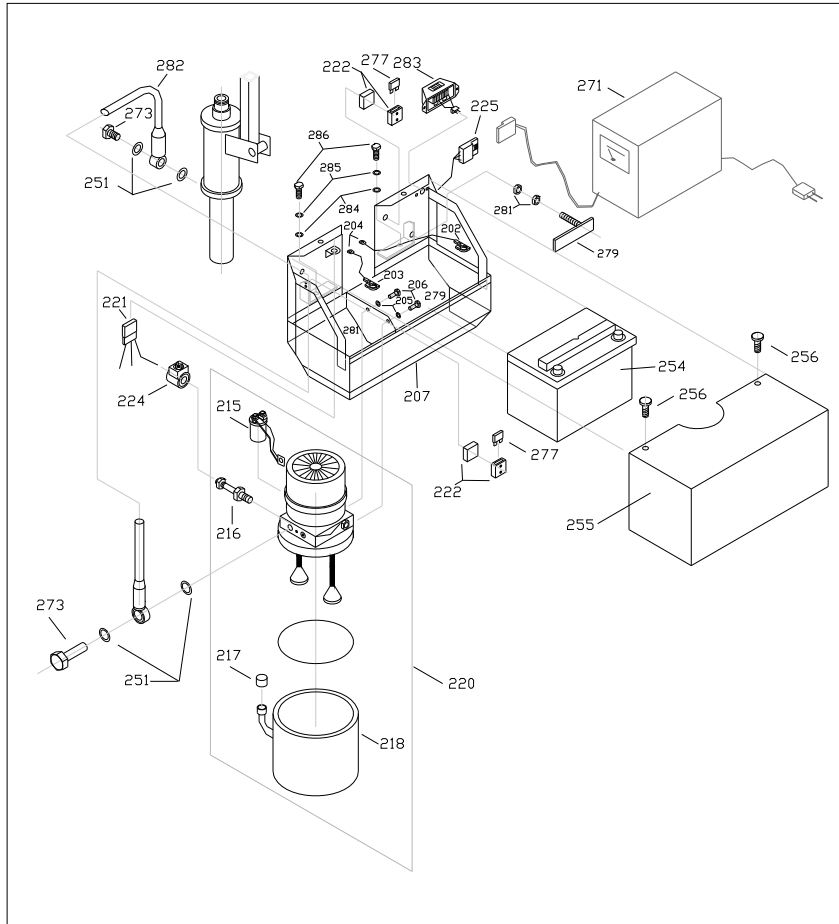

Item No.	Description	Q'ty
202	Battery Terminal (+)	1
203	Battery Terminal (-)	1
204	Terminal	2
205	Washer	2
206	Screw	2
207	Electric Control Case	1
215	Relay	1
216	Control Valve	1
217	Cap	1
218	Oil Tank	1
220	Pump Station Assembly	1
221	Switch Socket	1
222	Fuse Box	2
224	Magnet	1
225	Recharger Socket	1
251	Washer	4
254	Battery ,12V/63Ah	1
255	Cover	1
256	Screw	2
271	Recharger, 12V/10A	1
273	Screw	2
277	Fuse,5A	2
279	Fixing Screw for Battery	2
281	Nut	2
282	High Pressure Oil Pipe	1
283	Voltage Meter	1
284	Washer	2
285	Washer	2
286	Screw	2

EXPLODED FIGURE & PARTS LIST OF PUMP ASSEMBLY

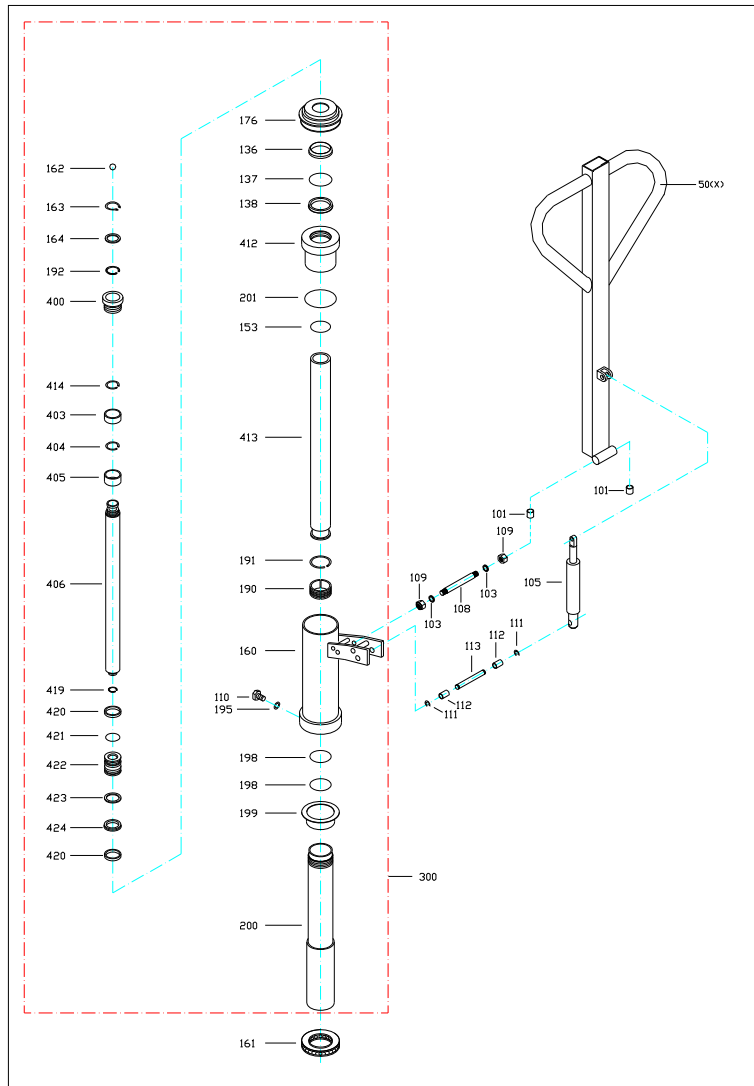

Item No.	Description	Remark
101	Spacer	2
103	Washer	2
105	Tension spring	1
108	Pin	1
109	Nut	2
110	Adjusting screw	1
111	Snap ring	2
112	Sleeve	2
113	Pin	1
136	Scraper ring	1
137	O-ring	1
138	Y-ring	1
153	O-ring	1
160	Pump housing	1
161	Thrust bearing	1
162	Ball	1
163	Snap ring	1
164	Washer	1
176	Rubber sleeve	1
190	Copper piston	1
191	Snap ring	1
192	Snap ring	1
195	Washer	1
198	O-ring	2
199	Bushing	1
200	Cylinder	1
201	Back-Up ring	1
400	Bronze Bushing	1
403	Bushing	1
404	Snap Ring	1

405	Bushing	1
406	Piston Rod	1
412	Cylinder Head	1
413	Cylinder	1
414	Snap Ring	1
418	insulated washer	2
419	Snap ring	1
420	Bushing	2
421	O-Ring	1
422	Piston	1
423	Back-Up Ring	1
424	Y-Ring	1
50(X)	Handle assembly	1
300	Pump Unit	1
*	Seal Kits: 136#、137#、138#、201#、153#、 198#、401#、402#、420#、421#、 423#、424#	1

HANDLE ASSEMBLY -50

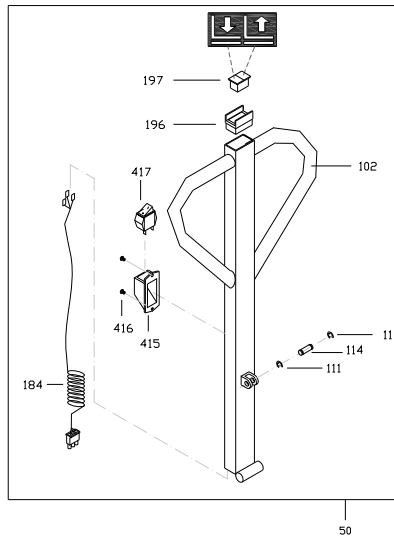

Item No.	Description	Remark
102	Handle	1
111	Snap ring	2
114	Pin	1
184	Switch wire & plug	1
196	Switch housing	1
197	Up-down switch	1
415	Switch housing	1
416	Screw	2
417	switch	1

HANDLE ASSEMBLY -50X

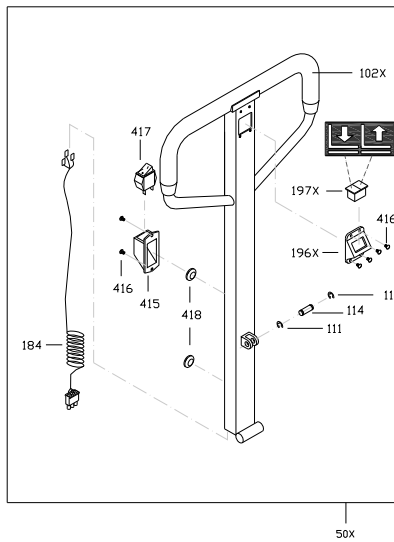

Item No.	Description	Remark
102X	Handle	1
111	Snap ring	2
114	Pin	1
184	Switch wire & plug	1
196X	Switch housing	1
197X	Up-down switch	1
415	Switch housing	1
416	Screw	6
417	switch	1
418	insulated washer	2

* **VERSION EIGHT**

12/2010