

PSE10MSL **NEW!**

INTRODUCTION

The PSE10 is an economic walkie electric stacker, with rated capacity of 1000kg and lifting height from 1600mm to 3500mm. The compact and light design is suitable for a variety of low duty applications in warehouses.

ADVANTAGES:

- Ideal solution for low cycle applications.
- Built in charger for high autonomy.
- Battery discharge indicator with lift lock-out for improved battery life.
- 3-points design with centered drive for stability and traction.
- Mono-mast or wide space between masts for perfect view.



PSE10MSL

PSE10SL

Several masts options

Mono mast for 1600mm and 200mm lift heights.
Duplex mast for 2500mm, 3200mm and 3500mm lift heights.



Adjustable straddle led

Adjustable straddle leg design, suitable for diverse pallet sizes and more stability. Low silhouette straddle design allows a lower bottom beam when accessing your rack which increases storage in the facility.

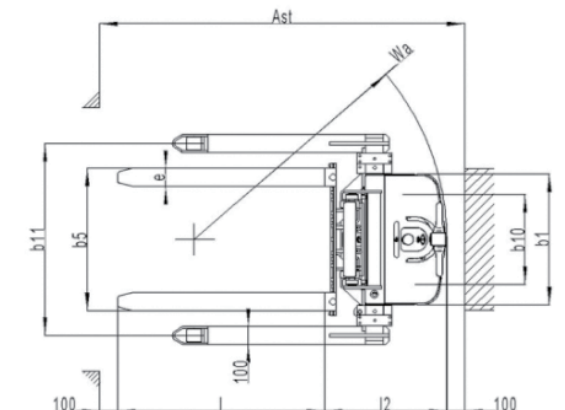
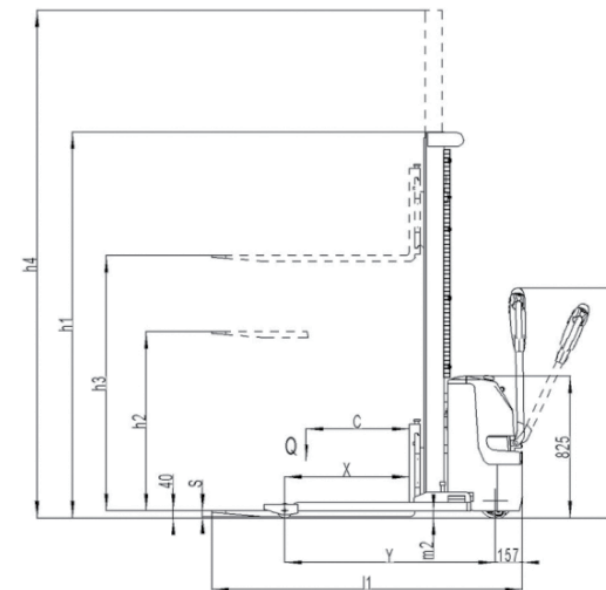
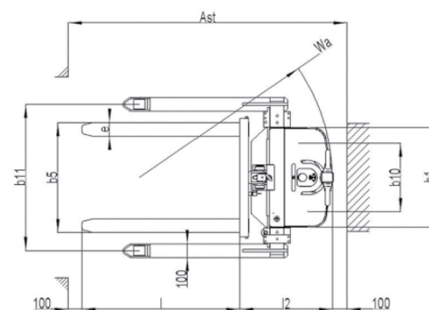
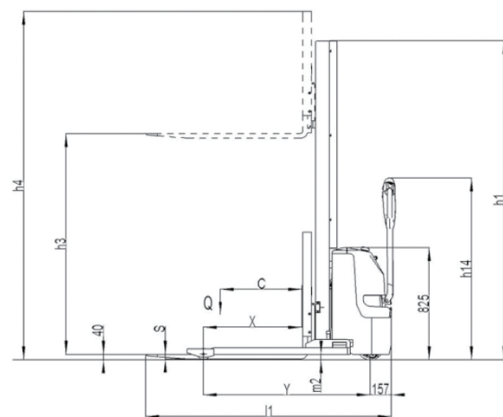



Built-in charger

The built-in charger allows charging anywhere in your work area, allowing higher efficiency for your work force.

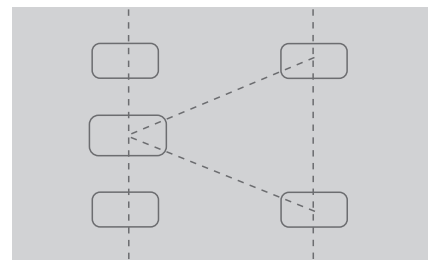

Stability

3-point design for improved traction with 2 stability casters for improved safety.



Robust profile

Interlocking, high tensile steel mast design for unlimited life and accurate lifting.



Powerful battery



Battery deep discharge protection

Lift lock-out improves the useful life of the battery. Tested and ergonomically designed emergency disconnect standard.

High Quality Components

All switches, sensors, and operating components are high quality, fully tested products.

Certification

Meets or exceeds EC standards as well as ISO 13849.

Applications

Ideal economic solution for all indoor low duty stacking operations.



Robust handle

Type sheet for industrial truck acc. to VDI 2198 1KG=2.2LB 1INCH=25.4MM

Distinguishing mark	1.2 Manufacturer's type designation	1.3 Power (battery ,diesel, petrol, gas, manual)	1.4 Operator type	PSE 10MSL(1600) PSE 10MSL(2000) PSE10SL(2900) PSE10SL(3200) PSE10SL(3500)				
				Battery		Battery		
Weight	1.5 Load Capacity / rated load	1.6 Load centre distance	1.7 Q (t)	Pedestrian		Pedestrian		
				1000	1000	1000	1000	1000
Weight	1.8 Load distance ,centre of drive axle to fork	c (mm)	600	600	600	600	600	600
	1.9 Wheelbase	x (mm)	732	725	725	725	725	
		y (mm)	1228	1228	1228	1228	1228	
Tires, chassis	2.1 Service weight	kg	637	650	722	737	752	
	2.2 Axle loading, laden front/rear	kg	518/1111	522/1120	577/1138	582/1148	587/1158	
	2.3 Axle loading, unladen front/rear	kg	452/185	461/189	513/219	523/214	533/219	
	3.1 Tires		Polyurethane(PU)		Polyurethane(PU)			
	3.2 Tire size,front	Φxw (mm)	Φ200×73		Φ200×73			
	3.3 Tire size,rear	Φxw (mm)	Φ84×70		Φ84×70			
	3.4 Additional wheels(dimensions)	Φxw (mm)	Φ80×30		Φ80×30			
Dimensions	3.5 Wheels,number front/rear(x=driven wheels)		1x +2/2		1x +2/2			
	3.6 Tread, front	b ₁₀ (mm)	498		498			
	3.7 Tread, rear	b ₁₁ (mm)	1070-1370		1070-1370			
	4.2 Lowered mast height	h ₁ (mm)	1950	2350	1945	2095	2245	
	4.3 Free Lift height	h ₂ (mm)	1530	1930	70	70	70	
	4.4 Lift height	h ₃ (mm)	1530	1930	2840	3140	3440	
	4.5 Extended maximal height	h ₄ (mm)	2470	2870	3420	3720	4020	
Performance data	4.9 Height of tiller in drive position min./ max.	h ₁₄ (mm)	825/1250		825/1250			
	4.15 Height, lowered	h ₁₃ (mm)	40		40			
	4.19 Overall length	l ₁ (mm)	1810		1810			
	4.20 Length to face of forks	l ₂ (mm)	660		660			
	4.21 Overall width	b ₁ (mm)	726		726			
	4.22 Fork dimensions	s/e/l (mm)	35x100x1150		35x100x1150			
	4.25 Distance between fork-arms	b ₅ (mm)	252-800		252-800			
	4.32 Ground clearance, centre of wheelbase	m ₂ (mm)	40		40			
	4.33 Aisle width for pallets 1000X1200 crossways	Ast (mm)	2262		2251			
	4.34 Aisle width for pallets 800X1200 lengthways	Ast (mm)	2221		2200			
	4.35 Turning radius	Wa (mm)	1405		1405			
Electric- engine	5.1 Travel speed, laden/ unladen	km/h	3.7/4.0		3.9/4.1			
	5.2 Lift speed, laden/ unladen	m/s	0.12/0.18		0.105/0.145			
	5.3 Lowering speed, laden/ unladen	m/s	0.16/0.12		0.103/0.102			
	5.8 Max. gradeability, laden/ unladen	%	5/10		5/10			
	5.10 Service brake		Electromagnetic		Electromagnetic			
Additional data	6.1 Drive motor rating S2 60min	kW	0.45		0.45			
	6.2 Lift motor rating at S3 4.5%	kW	2.2		2.2			
	6.3 Battery acc. to DIN 43531/35/36 A, B, C, no		No		No			
	6.4 Battery voltage, nominal capacity K5	V / Ah	2x12/85 ¹⁾		2x12/85 ¹⁾			
	6.5 Battery weight +/-5%	kg	2x25		2x25			
	6.6 Energy consumption acc: to VDI cycle	kWh/h	0.62		0.62			
Additional data	8.1 Type of drive control		DC		DC			
	8.4 Sound level at driver's ear acc. to EN 12053	dB(A)	<70		<70			