

NOBLELIFT

**Manual &
Semi-Electric
Stacker
Adjustable Base Legs
2200 LBS**



SPN22AG

Lift Height >
Single mast: 63"
Duplex mast: 98"/118"

SFH22AG

< Lift Height
Single mast: 63"
Duplex mast: 98"/118"/137"



SFH22AG

1KG=2.2LB 1INCH=25.4MM

Manual Hydraulic Stackers – Adjustable Base Legs

Model		SFH22-63	SFH22-98	SFH22-118
Capacity	lbs	2200	2200	2200
Lifting Height Max.	inch	63	98	118
Lifting Height Min.	inch	23/4	23/4	23/4
Fork Length	inch	36	36	36
Fork Width	inch	4	4	4
Outer width of forks	inch	8.5-33.5	8.5-33.5	8.5-33.5
Base legs I.D.	inch	36 to 48	36 to 48	36 to 48
Base legs O.D.	inch	43 to 54	43 to 54	43 to 54
Overall Length	inch	56	56	56
Overall Width	inch	43 to 54	43 to 54	43 to 54
Overall Height	inch	79 1/2	69 3/4	79 1/2
Load Center	inch	20	20	20
Front Caster Dia.	inch	4	4	4
Rear Caster Dia.	inch	7	7	7
Front Wheel Dia.	inch	5	5	5
Rear Wheel Dia.	inch	7	7	7
Wheel Type	inch	2 Rigid, 2 Swivel	2 Rigid, 2 Swivel	2 Rigid, 2 Swivel
Shipping Weight	lbs	705	795	850

SFH22AG

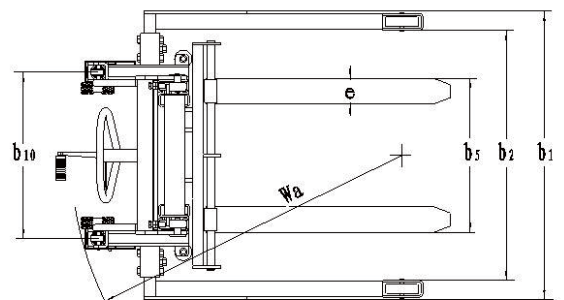
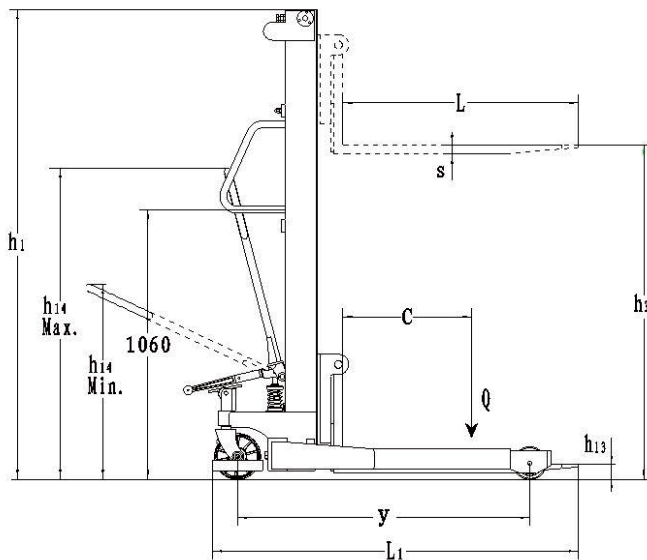

SPN22AG

1KG=2.2LB 1INCH=25.4MM

Manual Hydraulic Stackers – Adjustable Base Legs

Model		SPN22-63	SPN22-98	SPN22-118	SPN22-138
Capacity	lbs	2200	2200	2200	2200
Lifting Height Max.	inch	63	98	118	138
Lifting Height Min.	inch	21/8	21/8	21/8	21/8
Fork Length	inch	42	42	42	42
Fork Width	inch	4	4	4	4
Base legs I.D.	inch	38 to 50	38 to 50	38 to 50	38 to 50
Base legs O.D.	inch	46 to 58	46 to 58	46 to 58	46 to 58
Overall Length	inch	66 1/2	66 1/2	66 1/2	66 1/2
Overall Width	inch	46 to 58	46 to 58	46 to 58	46 to 58
Overall Height	inch	80	72	82	89 1/2
Load Center	inch	24	24	24	24
Voltage	V	12	12	12	12
Rear Caster Dia.	inch	7	7	7	7
Front Wheel Dia.	inch	5	5	5	5
Rear Wheel Dia.	inch	7	7	7	7
Wheel Type	inch	2 Rigid, 2 Swivel	2 Rigid, 2 Swivel	2 Rigid, 2 Swivel	2 Rigid, 2 Swivel

SPN22AG

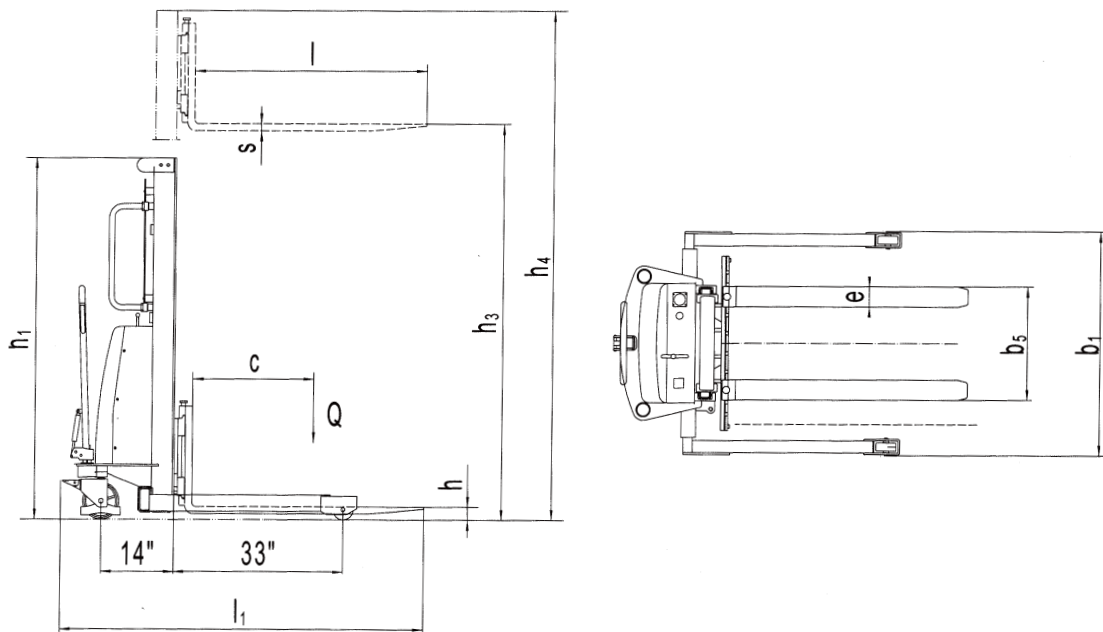

SPN22AG/SFH22AG

Manual & Semi-Electric Stacker

SFH22AG Manual Hydraulic Stackers – Adjustable Base Legs

- For lifting loads, skids, racks, and objects. Forks adjust from side to side to accommodate skid widths.
- Feature fold-away hydraulic foot pump for raising loads.
- Two-swivel and two rigid casters provide four wheel support for heavy loads.
- Include wheel lock and safety screen to ensure safety during operation.

SPN22AG Semi-electric Stacker – Adjustable Base Legs

- Adjustable base legs for lifting loads, skids, racks, and objects.
- Forks adjust from side to side to accommodate skid widths.
- Adjustable forks lowers to the minimum height 2 1/8".
- Study and reliable mast made of rolled U-profiles. Hard chrome plated piston. Adjustable lifting chain. Powerful lift motor 2.1 HP.
- Integrated 150 AH maintenance free battery supplies strong power to effect frequent lifting tasks, an integrated charger facilitates easy and reliable charging of the integrated battery.

AUTHORIZED DEALER

Noblelift Canada Inc.

850 Ellingham,
Pointe Claire, Qc H9R 3S4
TEL: 514.697.0117
WEB: www.nobleliftcanada.com
Email: info@nobleliftca.com