

# INTRODUCTION

The new model of electric pallet truck developed by Nobleliff is the innovative product with cutting-edge design based on decades of our experience, it combines the advantages of manual and electric pallet trucks being the perfect electrical product for light and medium duty material transportation in most effortless and economic way.

With its new and fresh outer appearance containing sharp lines, we named it "EDGE".

Smart design

Robustness

Safety

Ergonomics

High performance

Maintenance friendly



Official website Our Wechat

### Nobleliff Headquarters

Add: #528 Changzhou Road, Taihu Sub-district, Changxing, 313100, China  
TEL: +86 572 6210311/6120989  
FAX: +86 572 6210777  
WEB: www.nobleliff.com  
Email: info@nobleliff.com

### Nobleliff North America Corp.

Add: 2461 S Wolf Road, Des Plaines, IL 60018  
Tel: 847-595-7100  
Fax: 847-595-7200  
Email: sales@nobleliffna.com  
Http: www.nobleliffna.com

### Nobleliff Europe GmbH

Add: Borsigstrasse 9d-93092 Barbing Germany  
TEL: +49 9401 607930  
FAX: +49 9401 6079329  
WEB: www.nobleliffeurope.com  
Email: mail@nobleliffeurope.com

### Nobleliff Russia

ООО "Ноблелифт Рус"  
194292, Санкт-Петербург  
Домостроительная ул. 4А офис 301  
Бизнес-центр "Парнас"  
тел: +7 (800) 700-28-97  
Email: sales@nobleliff.com.ru



NEW Nobleliff Products  
ARRIVAL



**NOBLELIFT**

Material Handling

**EDGE**

Powered Pallet Truck



NOBLELIFT INTELLIGENT EQUIPMENT CO., LTD

www.nobleliff.com

## Ergonomic & Smart Tiller Design

The tiller of the truck with ergonomic design has comfortable soft grips for comfort daily operation. All buttons are big and can be easily reached by operators even in case of working in gloves.

**Integrated PIN code panel with LCD display** for smart control and operation.



The tiller of the truck is supported by the **air spring** and the tiller returns to its vertical position smoothly.

**Speed reduction** at different angles as well as function of active tiller in its up-right position.



Battery discharge indicator  
Operating hour counter  
On-board diagnostics via error codes



The function of driving with tiller in the **vertical position** helps with work in confined areas, especially in elevators and lorries without sacrificing of safety.

The frame of truck is surrounded by stamped steel elements making the truck looking different and also ensuring the **protection** of components

Forks of the truck with shape for easy entrance and exit from pallets. Full length double sided C-shape **reinforcements** of forks significantly increase strength and **rigidity** of frame.

**Strong steel apron protects** the operator's feet during work and secures the truck's components from collisions with objects.



## Robust & Smart Design of Chassis

Strong and compact structure of chassis helps to ensure long life-time of the truck, without sacrificing the truck's weight or putting under question the strength of frame.



Capacity up to **1500 kg** and ability to overcome ramps up to **4/16%** (laden/ unladen) makes the truck suitable for work in loading docks and on delivery operations in different conditions

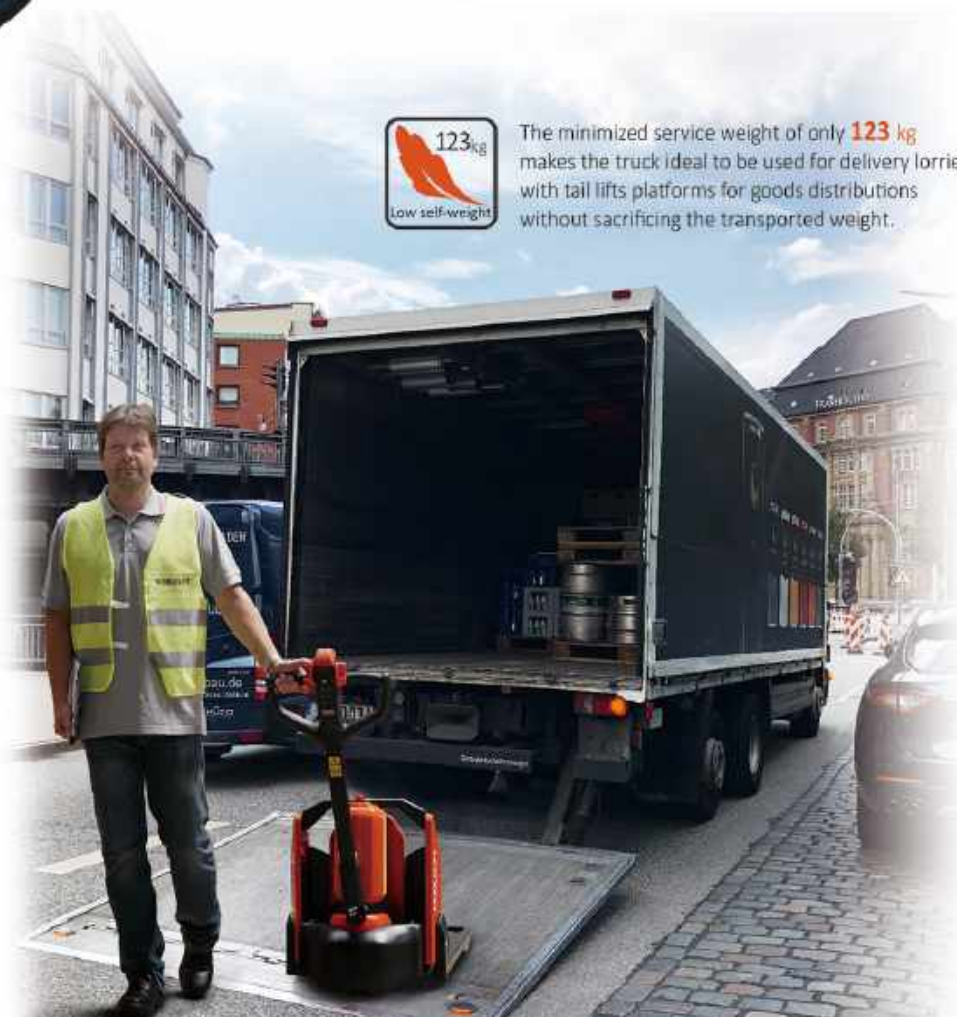

The minimized service weight of only **123 kg** makes the truck ideal to be used for delivery lorries with tail lifts platforms for goods distributions without sacrificing the transported weight.

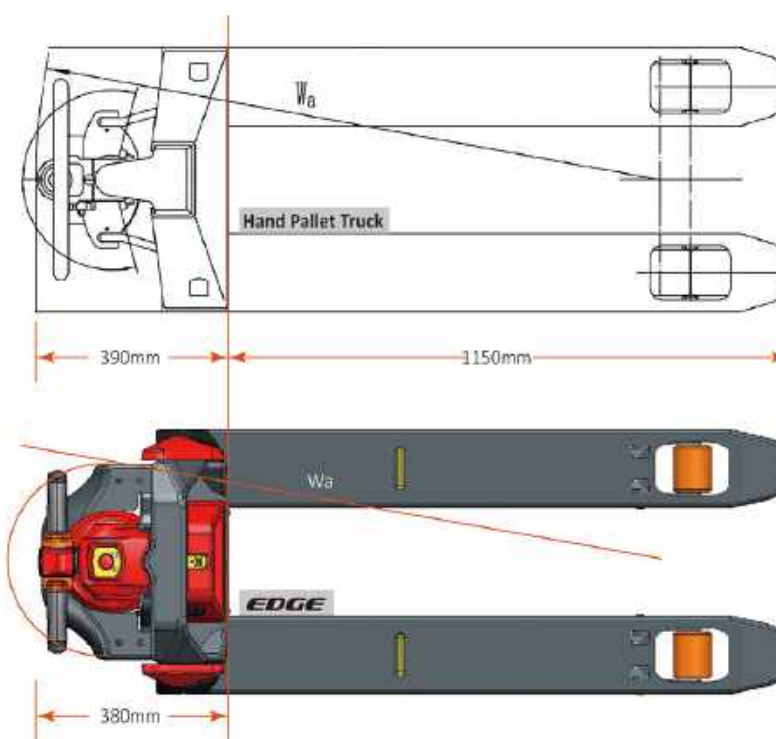

The short body length of truck (L2=380 mm) is even smaller than the one of regular HPTs. It provides the shortest **turning radius** of **1274/1330 mm** with lifted/lowered forks and makes the truck extremely compact and ideal for use in confined spaces of retail stores, elevators or business centers.

## Smart Lithium Battery



The Edge is equipped with **maintenance-free** Lithium battery with optional different capacities for various applications; with its fast charging and opportunity charging features the Edge works as easy as a hand pallet truck without special attention to the maintenance as other electric pallet trucks.

The integrated **BMS** (Battery Management System) controls all important parameters and performance of lithium battery.



Optional different battery capacities from 20Ah to 36Ah for various applications

Light weight high quality Lithium battery for **easy replacement**.



Smart battery positioning and lock for great fixation and safety.

Socket on battery case for easy battery charging without necessity to take the battery out. Fast and opportunity charging during brakes in operations increases working time.



3-6 hours working time



## Maintenance Friendly



**Convenient** and fast access to any component of the truck, no elements are located in areas difficult to reach. No Special tools are required.

There are no hoses or pipes used in the hydraulic lifting circuit which significantly improves **reliability** and reduces the amount of potential problems related to leakages through connectors or their seals.



The truck is equipped with **Curtis** controller and **CAN-bus** technology makes the diagnostic and troubleshooting easier.

Amount of working hours shown at the tiller helps to follow the maintenance schedule.

## Various Options



Optional tandem fork rollers



Optional different fork sizes



Additional supporting wheels